

NATUCER
cerámica natural



NATUCER

NATUCER CUORE, S.L.U C/ Les Forques, 2
12200 Onda [Castellón] Spain · Apdo. nº 6
Tel.: + [34] 964 60 40 66 [8 líneas]
info@natucer.es · www.natucer.es

NATUCER
cerámica natural

¿QUIENES SOMOS?

WHO WE ARE?

QUI SOMMES-NOUS?

Natucer inicia su andadura en la década de los 90, coincidiendo con el asentamiento de la revolución tecnológica española, ocurrida con la obtención de los revestimientos prensados con cocciones rápidas. Ofrece soluciones en gres porcelánico extrusionado para interiores y exteriores.

Pavimentos que integran funcionalidad, máxima calidad y un diseño con esencia artesanal.

Especialistas en todo tipo de piezas especiales que garantizan un acabado perfecto, como peldaños de gran formato o piezas específicas y técnicas para piscina.

Y revestimientos exclusivos al servicio de arquitectos, interioristas y decoradores sin limitaciones en cuanto a colores, formas, texturas, geometrías y volúmenes, para proyectos tanto residenciales como públicos o comerciales.

Natucer started by the end of the 90's, matching up with the Spanish technological revolution and the production of pressed wall tiles through quick fire. Natucer offers lots of possibilities inside and outside using our klinker extruded porcelain tile.

Floor tiles that join the functionality with the maximum quality and a design with artisanal essence. Natucer is specialized in all type of special pieces to make a perfect finish, such as large steps 120 cm long, or special technic pieces for pools.

Wall tiles that have been created for architects and interior designers that look unique and exclusive finishes, without limitation in colors, sizes, textures, 3Ds for all projects: residential, public and commercial.

Natucer a débuté son activité dans les années 90, coïncidant avec l'essor de la révolution technologique espagnole, marquée par l'apparition des revêtements pressés à cuisson rapide. Elle propose des solutions en grès cérame extrudé pour l'intérieur comme pour l'extérieur : des pavements qui allient fonctionnalité, qualité maximale et design à l'essence artisanale.

Spécialistes de tous types de pièces spéciales garantissant une finition parfaite, telles que des marches de grand format ou des éléments techniques spécifiques pour piscines.

Des revêtements exclusifs au service des architectes, designers d'intérieur et décorateurs, sans limitation de couleurs, formes, textures, géométries ou volumes, pour des projets résidentiels, publics ou commerciaux.

cerámica natural

NATUCER
cerámica natural

Since 1988

¿QUÉ HACEMOS?

WHAT WE DO?
QUE FAISONS-NOUS?

Utilizamos únicamente las mejores materias primas: arcillas naturales y agua, sometidas a un proceso de molido especial que aumenta la densidad y minimiza la porosidad.

Esta mezcla pasa posteriormente por la extrusora, una boquilla que forma el volumen de las piezas. De esta manera se obtiene una pasta densa y homogénea que se corta en piezas de cualquier tamaño y forma deseada, logrando un producto único donde ninguna pieza es igual a otra.

Cocido a 1300 grados, lo que otorga al gres extrusionado su excepcional dureza y resistencia. Durante este proceso, las partículas de arcilla se fusionan, formando una estructura increíblemente compacta y sólida.

El resultado es un producto inalterable al paso del tiempo, resistente al hielo, antideslizante, ignífugo, higiénico, de fácil limpieza y con mantenimiento prácticamente inexistente. Además, el sistema de producción por extrusión permite una infinita variedad de formas, volúmenes y texturas, lo que hace de cada pieza una creación singular e irreplicable.

We use only the finest raw materials: natural clays and water, subjected to a special grinding process that increases density and minimizes porosity.

This mixture then passes through the extrusion machine, a nozzle that shapes the volume of the pieces. In this way, a dense and homogeneous paste is obtained, which is cut into pieces of any desired size and shape, resulting in a unique product where no two pieces are alike.

Fired at 1300 degrees, this process gives extruded stoneware its exceptional hardness and strength. During firing, the clay particles fuse together, forming an incredibly compact and solid structure.

The result is a product that remains unchanged over time, resistant to frost, non-slip, fireproof, hygienic, easy to clean, and virtually maintenance-free. Moreover, the extrusion production system allows us to create infinite variety of shapes, volumes, and textures, making each piece a unique and unrepeatable creation.

Nous utilisons exclusivement les meilleures matières premières : des argiles naturelles et de l'eau, soumises à un procédé de broyage spécifique qui augmente la densité et minimise la porosité.

Ce mélange passe ensuite par une extrudeuse, une filière qui donne le volume aux pièces. On obtient ainsi une pâte dense et homogène, découpée en éléments de toutes tailles et formes souhaitées, donnant naissance à un produit unique où aucune pièce n'est identique à une autre.

Cuite à 1300°C, cette matière confère au grès extrudé une dureté et une résistance exceptionnelles. Durant ce processus, les particules d'argile fusionnent pour former une structure extrêmement compacte et solide.

Le résultat est un produit : Inaltérable dans le temps résistant au gel, antidérapant, ignifuge, hygiénique, facile à nettoyer, nécessitant un entretien quasi inexistant. Le système de production par extrusion permet également une variété infinie de formes, volumes et textures, faisant de chaque pièce une création singulière et irréplicable.



ESPECIALIZADOS EN GRES PORCELÁNICO EXTRUSIONADO

SPECIALIZED IN EXTRUDED PORCELAIN STONEWARE
SPÉCIALISTES EN GRÈS CÉRAME EXTRUDÉ



TRADICIÓN Y NATURAL
TRADITION AND NATURE
TRADITIONNEL ET NATUREL



EFICIENCIA ENERGÉTICA
ENERGY EFFICIENCY
EFFICACITÉ ÉNERGÉTIQUE



SEGURA
SAFE
SÛR



IGNÍFUGA
FIREPROOF
IGNIFUGE



HIGIÉNICA Y ANTIALERGÉNICA
HYGIENIC AND ANTI-ALLERGENIC
HYGIÉNIQUE ET ANTIALLERGÉNIQUE



DURADERA Y RESISTENTE
DURABLE AND RESISTANT
DURABLE ET RÉSISTANT



LIMPIEZA Y MANTENIMIENTO
CLEANING AND MAINTENANCE
FACILE À NETTOYER ET À ENTREtenir



ESTÉTICA Y VERSÁTIL
ESTHETIC AND VERSATILE
ESTHÉTIQUE ET POLYVALENT



RESPONSABLE Y SOSTENIBLE
RESPONSIBLE AND SUSTAINABLE
RESPONSABLE ET DURABLE

¿CÓMO LO HACEMOS?

HOW WE DO IT?
COMMENT LE FAISONS-NOUS?

PREOCUPADOS.

La preocupación por el cuidado del entorno y la preservación del medioambiente han sido prioridad para la creación de esta nueva marca de la empresa Natucer. La sostenibilidad de nuestro estilo de vida y su necesario equilibrio con el medioambiente necesita de hechos concretos y acciones tangibles. Natucer es responsable en el proceso de fabricación para minimizar su impacto en el medioambiente.

COMPROMETIDOS.

Natucer se compromete con el cuidado del medioambiente y con los efectos que repercuten en el entorno debido a su actividad. Ha realizado importantes inversiones en infraestructura para adaptar y aplicar las mejoras técnicas y menos contaminantes en los procesos productivos. Algunos de los requisitos que se deben cumplir, entre otros, son: Vertidos, Emisiones atmosféricas y Gestión y procedimientos de residuos.

CONCERNED.

Concern for environmental care and preservation has been a priority in the creation of this new brand by Natucer. The sustainability of our lifestyle and its necessary balance with the environment requires concrete actions and tangible actions. Natucer is responsible in the manufacturing process to minimize its impact on the environment.

COMMITTED.

Natucer is committed to caring for the environment and addressing the effects its activities have on the environment. It has made significant investments in infrastructure to adapt and implement technical improvements and reduce pollution in its production processes. Some of the requirements that must be met, among others, are: Discharges, Air Emissions, and Waste Management and Procedures.

ENGAGÉS POUR L'ENVIRONNEMENT.

La préservation de l'environnement est une priorité dans la création de cette nouvelle marque. La durabilité de notre mode de vie et son nécessaire équilibre avec l'environnement exigent des actions concrètes et mesurables. Natucer agit de manière responsable dans ses processus de fabrication afin de minimiser son impact environnemental.

COMPROMIS.

Des investissements significatifs ont été réalisés pour adapter les infrastructures et intégrer les meilleures technologies disponibles dans les processus productifs, notamment en matière de: rejets, émissions atmosphériques, gestion des déchets.

PREOCUPADOS Y COMPROMETIDOS CON EL MEDIOAMBIENTE

CONCERNED AND COMMITTED TO THE ENVIRONMENT
SOUCIEUX ET ENGAGÉS POUR L'ENVIRONNEMENT



Contaminación acústica regulada
Regulated noise contamination
Pollution acoustique contrôlée

Continuo reciclaje
Continuous recycling
Recyclage continu



Ahorro energético fundamental
Fundamental energy savings
Économie d'énergie

Emisiones atmosféricas controladas
Controlled atmospheric emissions
Émissions atmosphériques maîtrisées



Gestión adecuada de los residuos
Correct waste management
Gestion responsable des déchets

Vertido cero
Zero waste
Zéro rejet

- PROBLEMAS + SOLUCIONES

- PROBLEMS + SOLUTIONS
- PROBLÈMES + SOLUTIONS

Natucer cuenta con una gran variedad de piezas especiales que no sólo garantizan un acabado perfecto, sino que también permiten resolver estéticamente aspectos arquitectónicos como bordes de piscina o escaleras. Piezas diseñadas para lograr soluciones específicas para pavimentos exigentes.

Natucer ofrece un pavimento ideal para emplazamientos arquitectónicos exteriores y zonas húmedas que precisen de exigentes prestaciones frente al deslizamiento. Pensado y fabricado para garantizar la máxima seguridad.

Natucer has a great variety of special pieces that not only guarantee a perfect finish, but also enables giving aesthetically ideas to architectural aspects such as edges of pool or stairs. Pieces designed to achieve specific solutions for specific floors.

Natucer offers an ideal floor for humid areas and exterior architectural sites that require special conditions in order to be antislip and avoid sliding. Designed and manufactured to guarantee maximum safety.

Natucer propose une large gamme de pièces spéciales garantissant non seulement une finition parfaite, mais permettant également de résoudre esthétiquement des éléments architecturaux tels que les bords de piscine ou les escaliers.

Des pièces conçues pour répondre aux exigences des pavements techniques, notamment en extérieur ou dans les zones humides nécessitant des performances élevées en matière d'antidérapance. Pensées et fabriquées pour garantir une sécurité maximale.

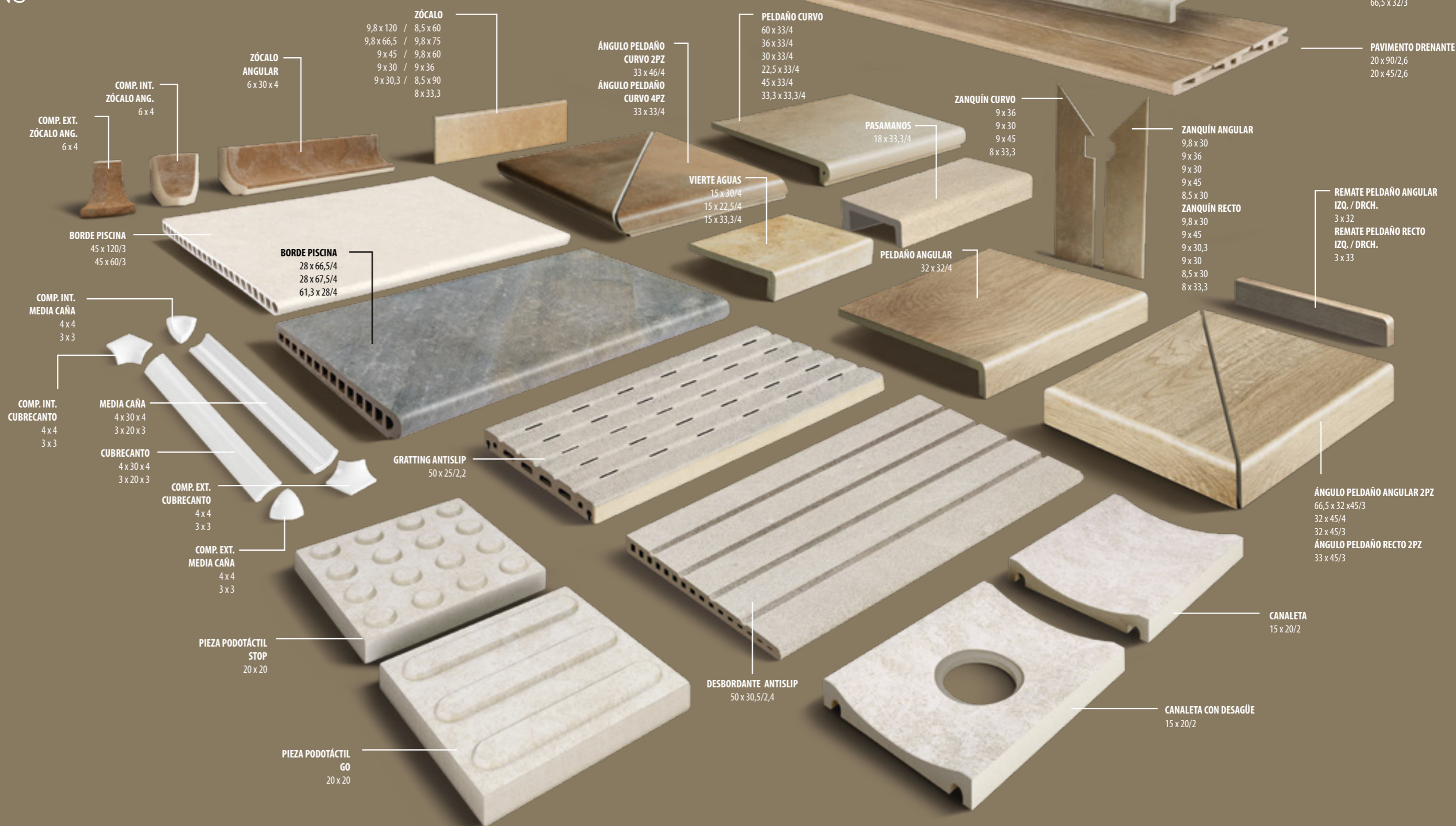

STEP 150
STEP 120

SIÉNTETE AUTOR DE TUS PROYECTOS CON NATUCER

WITH NATUCER, FEEL YOURSELF
AS THE ARTIST OF YOUR PROYECTS
SENTEZ-VOUS AUTEUR DE VOS PROJETS AVEC NATUCER

La cerámica se ha extendido por todo nuestro espacio. Sus propiedades de resistencia, versatilidad, seguridad y fácil mantenimiento además de ser antibacteriana e ignífuga han hecho que su zona de aplicación deje de limitarse a baños y cocinas.

Otra de sus ventajas es su capacidad de imitar otros materiales, que ni alcanzan las prestaciones que la cerámica ofrece ni son tan fáciles de mantener. Pudiendo así adaptarse a cualquier rincón del hogar, sea cual sea su estilo y con posibilidad de conseguir un interior coordinado con el exterior.

Tiles are all over our home. Its properties of resistance, versatility, safety and easy maintenance have made its application area no longer limited to bathrooms and kitchens.

The advantages of tiles are the ability to imitate other materials, which neither achieve the performance that ceramics offer but offer the easy maintainance of the tiles. Thus being able to adapt to any corner of the home, whatever its style is, and with the possibility of achieving an interior look of the house coordinated with the outside areas.

La cerámica s'est étendue à l'ensemble de nos espaces. Grâce à ses propriétés de résistance, de polyvalence, de sécurité et de facilité d'entretien, ainsi qu'à ses caractéristiques antibactériennes et ignifuges, son usage ne se limite plus aux salles de bains et aux cuisines.

Elle offre également la capacité d'imiter d'autres matériaux qui n'atteignent pas les performances techniques de la céramique et sont plus difficiles à entretenir.

Elle s'adapte ainsi à tous les espaces de vie, quel que soit le style, tout en permettant une parfaite continuité entre intérieur et extérieur.



Matera es la nueva tecnología de Natucer que impulsa el porcelánico a un nivel superior. Combina diseño y precisión tecnológica para crear superficies con carácter propio y excepcional. Cada pieza se convierte en una superficie única, donde relieves, texturas y acabados se integran con precisión para ofrecer una experiencia visual y táctil inigualable. Con Matora, el material trasciende su función tradicional, convirtiéndose en un elemento creativo y expresivo que aporta personalidad, elegancia y coherencia a proyectos arquitectónicos e interiores.

Su propuesta multiformato y acabados premium permiten a diseñadores y arquitectos explorar nuevas posibilidades, creando espacios con identidad y sofisticación. Matora garantiza calidad y durabilidad, consolidándose como referencia de innovación y diseño en el porcelánico, con soluciones que combinan estética, funcionalidad y alto valor, y una gran variedad de piezas especiales que aseguran acabado envolvente y continuidad visual en suelos, revestimientos y coronaciones, incluso para piscinas.

Matera is Natucer's new technology that takes porcelain to a higher level. It combines design and technological precision to create surfaces with exceptional character. Each piece becomes a unique surface, where reliefs, textures, and finishes integrate precisely to offer an unparalleled visual and tactile experience. With Matora, the material transcends its traditional function, becoming a creative and expressive element that adds personality, elegance, and coherence to architectural and interior projects.

Its multiformat range and premium finishes allow designers and architects to explore new possibilities, creating spaces with identity and sophistication. Matora guarantees quality and durability, establishing itself as a reference in porcelain innovation and design, with solutions that combine aesthetics, functionality, and high value, and a wide variety of special pieces that ensure seamless finishes and visual continuity in floors, coverings, and trims, even for pools.

Matera est la nouvelle technologie de Natucer qui élève le grès cérame à un niveau supérieur. Elle allie design et précision technologique pour créer des surfaces au caractère exceptionnel. Chaque pièce devient une surface unique, où reliefs, textures et finitions s'intègrent avec précision pour offrir une expérience visuelle et tactile incomparable. Avec Matora, le matériau dépasse sa fonction traditionnelle, devenant un élément créatif et expressif qui apporte personnalité, élégance et cohérence aux projets architecturaux et d'intérieur.

Sa gamme multiformat et ses finitions premium permettent aux designers et architectes d'explorer de nouvelles possibilités, créant des espaces avec identité et sophistication. Matora garantit qualité et durabilité, s'imposant comme une référence en innovation et design du grès cérame, avec des solutions alliant esthétique, fonctionnalité et grande valeur, et une grande variété de pièces spéciales assurant une finition harmonieuse et une continuité visuelle sur sols, revêtements et corniches, même pour les piscines.

Índice General

GENERAL INDEX

SERIES

| SERIES | | | |
|--------------------|-----------|-------------------|-----------|
| ALMA | 110 - 111 | MARE NOSTRUM | 238 - 239 |
| ALPES | 118 - 119 | NATURA | 150 - 153 |
| ALQUÉZAR | 154 - 155 | NATUR-TECH | 136 - 137 |
| AMERICAN DECOR | 66 - 67 | NATUR TRANSIT 2.0 | 132 - 135 |
| ANIMA | 112 - 115 | OLIMPO | 120 - 121 |
| ARGILE | 44 - 47 | ORION | 108 - 109 |
| ARGILE DECOR | 48 - 49 | PARK | 156 - 157 |
| ARTIES | 162 - 169 | PIASTRELLA MIX | 222 - 223 |
| AUSTRAL | 218 | PIEDRAS DEL BRUC | 126 - 127 |
| BOSTON | 64 - 65 | PIEMONTE | 74 - 77 |
| BOSTON BRICK | 68 - 69 | PIRINEOS | 128 - 129 |
| BOTANICA | 148 - 149 | POOL | 224 - 225 |
| CAPRI | 207 | POSETS | 122 - 125 |
| CERLER | 176 - 181 | RETRO | 158 - 159 |
| COOL | 204 - 205 | SAONA | 170 - 175 |
| COTTO BRICK | 50 - 51 | SARSEN STONE | 96 - 107 |
| COTTO NATURE | 70 - 73 | SARSEN STONE REV. | 196 - 201 |
| COTTAGE | 30 - 33 | SHERWOOD | 142 - 145 |
| COTTAGE DECOR | 32 - 33 | STOW / STOW MIX | 226 - 227 |
| D'ANTICATTO | 58 - 59 | TABARCA | 228 - 231 |
| D'ANTICATTO DECOR | 60 - 63 | TECH-GEO | 130 - 131 |
| EVOKE | 216 - 217 | TECH-LAND | 78 - 79 |
| FIKA | 214 - 215 | TECH-LAND DECOR | 80 - 83 |
| FRAME | 232 - 233 | TEMPO | 234 - 237 |
| FUEGO | 34 - 43 | TOSCANA | 182 - 187 |
| FUEGO DECOR | 38 - 43 | UNIKA | 52 - 55 |
| HERITAGE CLAY | 84 - 95 | UNIKA DECOR | 56 - 57 |
| HERITAGE CLAY REV. | 190 - 195 | VEGA | 219 |
| LANDS | 22 - 29 | WABI SABI | 202 - 203 |
| LIMESTONE | 116 - 117 | ZELLIGE | 220 - 221 |
| LINEAGE | 208 - 213 | ZERMATT | 146 - 147 |
| LIVERPOOL | 206 | | |

NOVEDADES

| NOVELTIES | | | |
|--------------------|-----------|-------------------|-----------|
| ARTIES | 162 - 169 | SARSEN STONE | 96 - 107 |
| CERLER | 176 - 181 | SARSEN STONE REV. | 196 - 201 |
| HERITAGE CLAY | 84 - 95 | SAONA | 170 - 175 |
| HERITAGE CLAY REV. | 190 - 195 | SHERWOOD | 138 - 145 |
| LANDS | 22 - 29 | TOSCANA | 182 - 187 |

NEW
2026

PAVIMENTO

| FLOOR TILE | | | |
|-------------------|-----------|--|--|
| ALMA | 110 - 111 | | |
| ALPES | 118 - 119 | | |
| ALQUÉZAR | 154 - 155 | | |
| AMERICAN DECOR | 66 - 67 | | |
| ANIMA | 112 - 115 | | |
| ARGILE | 44 - 47 | | |
| ARGILE DECOR | 48 - 49 | | |
| ARTIES | 162 - 169 | | |
| BOSTON | 64 - 65 | | |
| BOSTON BRICK | 68 - 69 | | |
| BOTANICA | 148 - 149 | | |
| CERLER | 176 - 181 | | |
| COTTO BRICK | 50 - 51 | | |
| COTTO NATURE | 70 - 73 | | |
| COTTAGE | 30 - 33 | | |
| D'ANTICATTO | 58 - 59 | | |
| D'ANTICATTO DECOR | 60 - 63 | | |
| FUEGO | 34 - 37 | | |
| FUEGO DECOR | 38 - 43 | | |
| HERITAGE CLAY | 84 - 95 | | |
| LANDS | 22 - 29 | | |
| LIMESTONE | 116 - 117 | | |
| NATURA | 150 - 153 | | |
| NATUR-TECH | 136 - 137 | | |
| NATUR TRANSIT 2.0 | 132 - 135 | | |
| OLIMPO | 120 - 121 | | |
| ORION | 108 - 109 | | |
| PARK | 156 - 157 | | |
| PIEDRAS DEL BRUC | 126 - 127 | | |
| PIEMONTE | 74 - 77 | | |
| PIRINEOS | 128 - 129 | | |
| POSETS | 122 - 125 | | |
| SAONA | 172 - 175 | | |
| SARSEN STONE | 96 - 107 | | |
| SHERWOOD | 138 - 145 | | |
| RETRO | 158 - 159 | | |
| TECH-GEO | 130 - 131 | | |
| TECH-LAND | 78 - 79 | | |
| TECH-LAND DECOR | 80 - 83 | | |
| TOSCANA | 182 - 187 | | |
| UNIKA | 52 - 55 | | |
| UNIKA DECOR | 56 - 57 | | |
| ZERMATT | 146 - 147 | | |

REVESTIMIENTO

| WALL TILE | | | |
|--------------------|-----------|--|--|
| AUSTRAL | 218 | | |
| CAPRI | 207 | | |
| COOL | 204 - 205 | | |
| EVOKE | 216 - 217 | | |
| FIKA | 214 - 215 | | |
| FRAME | 232 - 233 | | |
| HERITAGE CLAY | 84 - 95 | | |
| HERITAGE CLAY REV. | 190 - 195 | | |
| LINEAGE | 208 - 213 | | |
| LIVERPOOL | 206 | | |
| MARE NOSTRUM | 238 - 239 | | |
| PIASTRELLA MIX | 222 - 223 | | |
| POOL | 224 - 225 | | |
| SARSEN STONE | 96 - 107 | | |
| SARSEN STONE REV. | 196 - 201 | | |
| STOW / STOW MIX | 226 - 227 | | |
| TABARCA | 228 - 231 | | |
| TEMPO | 234 - 237 | | |
| VEGA | 219 | | |
| WABI SABI | 202 - 203 | | |
| ZELLIGE | 220 - 221 | | |

DECORADOS

| DECORATES | | | |
|-----------|---------|--|--|
| FIORANO | 48 | | |
| VENICE | 48 | | |
| VERSILIA | 74 - 77 | | |

Índice Tipologías

TIPOLOGY INDEX

TIPOLOGÍA

| TIPOLOGY | | | | | | | |
|--------------------|-----------|-----------------------------|-----------|-----------------------------|-----------------------|--------------------|-----------|
| BARRO COTTO | | HIDRÁULICO HYDRAULIC | | MIX COLOR BLENDED | PIEDRA STONE | | |
| AMERICAN DECOR | 66 - 67 | AMERICAN DECOR | 66 - 67 | CAPRI | 207 | ALMA | 110 - 111 |
| ARGILE | 44 - 47 | ANIMA DECOR | 114 - 115 | EVOKE | 216 - 217 | ALPES | 118 - 119 |
| ARGILE DECOR | 48 - 49 | ARGILE DECOR | 48 - 49 | FIKA | 214 - 215 | ANIMA | 112 - 115 |
| BOSTON | 64 - 65 | D'ANTICATTO DECOR | 60 - 63 | LIVERPOOL | 206 | ARTIES | 162 - 169 |
| BOSTON BRICK | 68 - 69 | FRAME | 232 - 233 | MARE NOSTRUM | 238 - 239 | CERLER | 178 - 181 |
| COTTO BRICK | 50 - 51 | FUEGO DECOR | 38 - 43 | PIASTRELLA MIX | 222 - 223 | HERITAGE CLAY | 84 - 95 |
| COTTO NATURE | 70 - 73 | TABARCA | 228 - 231 | POOL | 224 - 225 | HERITAGE CLAY REV. | 190 - 195 |
| COTTAGE | 30 - 33 | TECH-LAND DECOR | 80 - 83 | STOW / STOW MIX | 226 - 227 | LIMESTONE | 116 - 117 |
| D'ANTICATTO | 58 - 59 | TEMPO DECOR | 236 - 237 | ZELLIGE | 220 - 221 | NATUR TRANSIT 2.0 | 132 - 135 |
| D'ANTICATTO DECOR | 60 - 63 | UNIKA DECOR | 56 - 57 | ZERMATT | 146 - 147 | OLIMPO | 120 - 121 |
| FUEGO | 34 - 37 | | | | | ORION | 108 - 109 |
| FUEGO DECOR | 38 - 43 | | | | | PIEDRAS DEL BRUC | 126 - 127 |
| LANDS | 22 - 29 | | | | | PIRINEOS | 128 - 129 |
| PIEMONTE | 74 - 77 | | | | | POSETS | 122 - 125 |
| TECH-LAND | 78 - 79 | | | | | SAONA | 170 - 175 |
| TECH-LAND DECOR | 80 - 83 | | | | | SARSEN STONE | 96 - 107 |
| TOSCANA | 182 - 187 | | | | | SARSEN STONE REV. | 196 - 201 |
| UNIKA | 52 - 55 | | | | | TECH-GEO | 130 - 131 |
| | | | | | | TEMPO | 234 - 237 |
| BRICK BRICK | | MADERA WOOD | | PAVIMENTO DRENANTE | PISCINAS POOLS | | |
| BOSTON BRICK | 68 - 69 | ALQUÉZAR | 154 - 155 | DRAINING FLOOR TILE | | | |
| CAPRI | 207 | BOTANICA | 148 - 149 | NATUR-TECH | 136 - 137 | PIRINEOS | 128 - 129 |
| COOL | 204 - 205 | NATURA | 150 - 153 | | | POOL | 224 - 225 |
| COTTO BRICK | 50 - 51 | NATUR-TECH | 136 - 137 | | | | |
| EVOKE | 216 - 217 | PARK | 156 - 157 | PAVIMENTO PODOTACTIL | | | |
| FUEGO | 34 - 43 | RETRO | 158 - 159 | PODOTACTILE FLOOR TILE | | | |
| LINEAGE | 208 - 213 | SHERWOOD | 138 - 145 | NATUR 2.0 TRANSIT | 132 - 135 | | |
| LIVERPOOL | 206 | ZERMATT | 146 - 147 | | | | |
| PIASTRELLA MIX | 222 - 223 | | | PAVIMENTO INDUSTRIAL | | | |
| TABARCA | 228 - 231 | | | INDUSTRIAL FLOOR TILE | | | |
| WABI SABI | 202 - 203 | | | NATUR 2.0 TRANSIT | 132 - 135 | | |
| ZELLIGE | 220 - 221 | | | | | | |

Índice Formatos

SIZES INDEX · INDEX DES FORMATS



160 x 160 RECT. · 64" x 64"

SARSEN STONE 102 - 103

120 x 120 RECT. · 48" x 48"

HERITAGE CLAY 90 - 91

SARSEN STONE 102 - 103

90 x 90 RECT. 35,4" x 35,4"

ALMA 110 - 111

ANIMA 112 - 115

ORION 108 - 109

60 x 60 · 23,6" x 23,6"

COTTAGE 30 - 31

COTTAGE DECOR 32 - 33

HERITAGE CLAY 90 - 91

LANDS 22 - 29

LIMESTONE 116 - 117

SARSEN STONE 102 - 103



30 x 180 RECT. · 11,8" x 72"

SHERWOOD 144 - 145

25 x 150 RECT. · 10" x 60"

BOTÁNICA 148 - 149

NATURA 150 - 151

SHERWOOD 142 - 143

ZERMATT 146 - 147

20 x 120 RECT. · 8" x 48"

ALQUÉZAR 154 - 155

NATURA 152 - 153

PARK 156 - 157

SHERWOOD 142 - 143

45 x 45 · 17,7" x 17,7"

ARGILE 44 - 45

FUEGO 34 - 35

LANDS 22 - 29

36 x 36 · 14" x 14"

BOSTON 64 - 65

COTTO NATURE 70 - 73

PIEMONTE 74 - 77

POSETS 124 - 125

33,3 x 33,3 · 13,1" x 13,1"

CERLER 180 - 181

TOSCANA 186 - 187

30 x 30 · 11,8" x 11,8"

COTTAGE 30 - 31

COTTO NATURE 70 - 71

TECH LAND 78 - 79

LIMESTONE 116 - 117

22,5 x 22,5 · 8" x 8"

AMERICAN DECOR 66 - 67

ANIMA ANTISLIP 114 - 115

ARGILE 44 - 45

ARGILE DECOR 48 - 49

BOSTON 64 - 65

D'ANTICATTO 58 - 59

D'ANTICATTO DECOR 60 - 63

FUEGO 34 - 35

FUEGO DECOR 38 - 43

LANDS 22 - 29

TABARCA 228 - 231

TECH GEO 130 - 131

TECH LAND 78 - 79

TECH LAND DECOR 80 - 83

TEMPO 236 - 237

UNIKA 52 - 53

UNIKA DECOR 56 - 57

10 x 10 · 4" x 4"

FIKA 214 - 215

POOL 224 - 225

STOW/STOW MIX 226 - 227

18 x 18 · 7" x 7"

COTTO NATURE 72 - 73

MARE NOSTRUM 238 - 239

PIEMONTE 76 - 77

POSETS ANTISLIP 124 - 125

15 x 15 · 6" x 6"

ARGILE 44 - 47

HERITAGE CLAY 90 - 91

HERITAGE CLAY REV. 194 - 195

PIRINEOS 128 - 129

SARSEN STONE 102 - 103

SARSEN STONE REV. 200 - 201

11 x 11 · 4,3" x 4,3"

TEMPO 236 - 237

30,5 x 30,5 ENM. · 12" x 12"

FIKA 214 - 215

POOL 224 - 225

20 x 20 · 8" x 8"

NATUR TRANSIT 2.0 132 - 135



60 x 120 RECT. · 23,6" x 48"

ALPES 118 - 119

HERITAGE CLAY 90 - 95

OLIMPO 120 - 121

POSETS 122 - 123

SARSEN STONE 102 - 107

40 x 120 RECT. · 16" x 48"

AUSTRAL 218

VEGA 219

60 x 90 · 24" x 35,4"

HERITAGE CLAY 94 - 95

SARSEN STONE 106 - 107

36 x 72 · 14" x 28"

POSETS 124 - 125

45 x 67,5 · 17,7" x 26,5"

PIEDRAS DEL BRUC 126 - 127

MODULAR MODULAR



ARGILE 44 - 45

BOSTON 64 - 65

COTTO NATURE 70 - 73

D'ANTICATTO 58 - 59

HERITAGE CLAY 90 - 91

LANDS 22 - 29

LIMESTONE 116 - 117

PIEMONTE 70 - 77

POSETS ANTISLIP 124 - 125

SARSEN STONE 102 - 103

TECH-GEO 130 - 131

TECH-LAND 78 - 79

UNIKA 52 - 53

22 x 67,5 · 17,7" x 26,5"

PIEDRAS DEL BRUC 126 - 127

33 x 66,5 · 13" x 26,5"

PIRINEOS 128 - 129

30,3 x 61,3 · 11,9" x 24,1"

ARTIES 166 - 169

SAONA 174 - 175

30 x 60 · 11,8" x 23,6"

HERITAGE CLAY 90 - 91

SARSEN STONE 102 - 103

21 x 60 · 8" x 23,6"

RETRO 158 - 159

20 x 60 · 8" x 24"

FIKA 214 - 215

STOW/STOW MIX 226 - 227

ESTRELLA STAR



ARGILE 46 - 47

COTTAGE 30 - 31

LANDS 22 - 29

LIMESTONE 116 - 117

PIEMONTE 74 - 75

TECH-LAND DECOR 82 - 83

UNIKA 54 - 55

PROVENZAL PROVENZAL



MARE NOSTRUM 238 - 239

25 x 50 ENM. · 10" x 20"

CAPRI 207

22,5 x 45 · 8,8" x 17,7"

ARGILE 44 - 45

BOSTON 64 - 65

D'ANTICATTO 58 - 59

LANDS 22 - 29

UNIKA 52 - 53

22,5 x 33 · 8,8" x 13"

TECH LAND 78 - 79

TECH GEO 130 - 131

20 x 30 · 8" x 13"

NATUR TRANSIT 2.0 132 - 135

10 x 20 · 4" x 8"

FIKA 214 - 215

18 x 36 · 7" x 14"

COTTO NATURE 72 - 73

PIEMONTE 76 - 77

POSETS ANTISLIP 124 - 125

11 x 33 · 8,8" x 13"

TABARCA 228 - 231

15 x 30 · 6" x 12"

FUEGO 34 - 35

FUEGO DECOR 38 - 43

FRAME 232 - 233

11 x 22,5 · 4,3" x 8,8"

BOSTON 64 - 65

D'ANTICATTO 58 - 59

LANDS 22 - 25

TABARCA 228 - 229

TECH LAND 78 - 79

TEMPO 234 - 235

TECH GEO 130 - 131

UNIKA 52 - 53

Índice Acabados

FINISHES INDEX · INDEX DES FINITIONS

ANTIDESLIZAMIENTO ANTISLIP

CLASE I - R9 UNE-EN-16165 - ANEXO C - B

| | |
|--------------------|-----------|
| ALMA | 110 - 111 |
| ALPES | 118 - 119 |
| ALQUÉZAR | 154 - 155 |
| ANIMA | 112 - 115 |
| ARGILE | 44 - 47 |
| ARGILE DECOR | 48 - 49 |
| BOSTON BRICK | 68 - 69 |
| BOTANICA | 148 - 149 |
| COTTO NATURE | 72 - 73 |
| COTTAGE | 30 - 31 |
| COTTAGE DECOR | 32 - 33 |
| FUEGO | 34 - 35 |
| HERITAGE CLAY | 90 - 91 |
| HERITAGE CLAY REV. | 190 - 195 |
| LANDS | 22 - 29 |
| LIMESTONE | 116 - 117 |
| NATURA | 150 - 153 |
| OLIMPO | 120 - 121 |
| ORION | 108 - 109 |
| PARK | 156 - 157 |
| PIEDRAS DEL BRUC | 126 - 127 |
| PIEMONTE | 76 - 77 |
| PIRINEOS | 128 - 129 |
| POOL | 224 - 225 |
| POSETS | 122 - 123 |
| SARSEN STONE | 102 - 105 |
| SARSEN STONE REV. | 196 - 201 |
| SHERWOOD | 142 - 145 |
| ZERMATT | 146 - 147 |

CLASE II - R10 UNE-EN-16165 - ANEXO C - B

| | |
|--------------|-----------|
| ARGILE DECOR | 48 - 49 |
| COTTAGE | 32 - 33 |
| COTTO BRICK | 50 - 51 |
| FUEGO | 34 - 37 |
| FUEGO BRICK | 36 - 37 |
| FUEGO DECOR | 38 - 43 |
| LANDS | 22 - 29 |
| LIMESTONE | 116 - 117 |
| OLIMPO | 120 - 121 |
| UNIKA | 52 - 57 |
| UNIKA DECOR | 56 - 57 |

CLASE III - R10 UNE-EN-16165 - ANEXO C - B

| | |
|----------|---------|
| PIEMONTE | 74 - 75 |
|----------|---------|

CLASE III - R11 UNE-EN-16165 - ANEXO C - B

| | |
|-------------------|-----------|
| ALMA | 110 - 111 |
| ALPES | 118 - 119 |
| ALQUÉZAR | 154 - 155 |
| ANIMA | 112 - 115 |
| ARGILE | 44 - 45 |
| ARTIES | 162 - 169 |
| BOTANICA | 148 - 149 |
| CERLER | 178 - 181 |
| COTTO NATURE | 70 - 71 |
| COTTAGE | 30 - 31 |
| D'ANTICATTO | 58 - 59 |
| D'ANTICATTO DECOR | 60 - 63 |
| FUEGO | 34 - 35 |
| HERITAGE CLAY | 90 - 95 |
| LANDS | 22 - 29 |
| LIMESTONE | 116 - 117 |
| NATURA | 150 - 153 |
| NATUR-TECH | 136 - 137 |
| ORION | 108 - 109 |
| PARK | 156 - 157 |
| POOL | 224 - 225 |
| POSETS | 122 - 125 |
| RETRO | 158 - 159 |
| SAONA | 172 - 175 |
| SARSEN STONE | 102 - 107 |
| SHERWOOD | 142 - 145 |
| TECH-GEO | 130 - 131 |
| TECH-LAND | 78 - 79 |
| TECH-LAND DECOR | 80 - 83 |
| TOSCANA | 182 - 187 |
| ZERMATT | 146 - 147 |

CLASE III - R12 UNE-EN-16165 - ANEXO C - B

| | |
|-------------------|-----------|
| AMERICAN DECOR | 66 - 67 |
| ANIMA | 114 - 115 |
| BOSTON | 64 - 65 |
| BOSTON BRICK | 68 - 69 |
| NATUR TRANSIT 2.0 | 132 - 135 |
| PIEDRAS DEL BRUC | 126 - 127 |

CLASE III - R13 UNE-EN-16165 - ANEXO C - B

| | |
|----------|-----------|
| PIRINEOS | 128 - 129 |
|----------|-----------|

CLASE B UNE-EN-16165 - ANEXO A

| | |
|----------|-----------|
| ALPES | 118 - 119 |
| ALQUÉZAR | 154 - 155 |
| BOTANICA | 148 - 149 |
| NATURA | 150 - 153 |
| OLIMPO | 120 - 121 |
| PARK | 156 - 157 |

CLASE C UNE-EN-16165 - ANEXO A

| | |
|-------------------|-----------|
| AMERICAN DECOR | 66 - 67 |
| ANIMA | 112 - 115 |
| ARGILE | 44 - 45 |
| BOSTON | 64 - 65 |
| BOSTON BRICK | 68 - 69 |
| D'ANTICATTO | 58 - 59 |
| D'ANTICATTO DECOR | 60 - 63 |
| NATUR TRANSIT 2.0 | 132 - 135 |
| PIEDRAS DEL BRUC | 126 - 127 |
| PIEMONTE | 74 - 77 |
| PIRINEOS | 128 - 129 |
| TECH-LAND | 78 - 79 |
| TECH-LAND DECOR | 80 - 83 |

RECTIFICADO RECTIFIED

| | |
|---------------|-----------|
| ALMA | 110 - 111 |
| ALPES | 118 - 119 |
| ALQUÉZAR | 154 - 155 |
| ANIMA | 112 - 115 |
| AUSTRAL | 218 |
| BOTANICA | 148 - 149 |
| HERITAGE CLAY | 90 - 95 |
| NATURA | 150 - 153 |
| NATUR-TECH | 136 - 137 |
| OLIMPO | 120 - 121 |
| ORION | 108 - 109 |
| PARK | 156 - 157 |
| PIRINEOS | 128 - 129 |
| POSETS | 122 - 125 |
| SARSEN STONE | 96 - 107 |
| SHERWOOD | 142 - 145 |
| VEGA | 219 |
| ZERMATT | 146 - 147 |

ESPESOR PAV. THICKNESS FLOOR

26 MM ESPESOR 1" THICKNESS

| | |
|------------|-----------|
| NATUR-TECH | 136 - 137 |
|------------|-----------|

20 MM ESPESOR 0,8" THICKNESS

| | |
|-------------------|-----------|
| NATUR TRANSIT 2.0 | 132 - 135 |
| HERITAGE CLAY | 94 - 95 |
| SARSEN STONE | 106 - 107 |

14 MM ESPESOR 0,5" THICKNESS

| | |
|-----------|-----------|
| TECH-GEO | 130 - 131 |
| TECH-LAND | 78 - 83 |

12 MM ESPESOR 0,4" THICKNESS

| | |
|------------------|-----------|
| ARGILE | 44 - 45 |
| COTTAGE | 30 - 31 |
| FUEGO | 34 - 43 |
| LANDS | 22 - 29 |
| LIMESTONE | 116 - 117 |
| PIEDRAS DEL BRUC | 126 - 127 |

Índice Piezas Especiales

SPECIAL PIECES INDEX · INDEX DES PIÈCES SPÉCIALES

PELDAÑO BLOCK BLOCK STEP



120 x 33/1,4 · 48" x 13,4/0,5"

| | |
|---------------|-----------|
| ARTIES | 162 - 169 |
| HERITAGE CLAY | 84 - 95 |
| SAONA | 172 - 175 |
| SARSEN STONE | 96 - 107 |
| SHERWOOD | 142 - 145 |

PELDAÑO ANGULAR ANGULAR STEP



120 x 32/3 · 48" x 12,5/1"

| | |
|----------|-----------|
| ALPES | 118 - 119 |
| ALQUÉZAR | 154 - 155 |
| ANIMA | 112 - 115 |
| BOTANICA | 148 - 149 |
| NATURA | 150 - 153 |
| OLIMPO | 120 - 121 |
| PARK | 156 - 157 |
| POSETS | 122 - 125 |

60 x 32/3 · 23,6" x 12,5/1"

| | |
|----------|-----------|
| ALPES | 118 - 119 |
| ALQUÉZAR | 154 - 155 |
| ANIMA | 112 - 115 |
| BOTANICA | 148 - 149 |
| NATURA | 150 - 153 |
| OLIMPO | 120 - 121 |
| PARK | 156 - 157 |
| POSETS | 122 - 125 |

67,5 x 32/3 · 26,5" x 12,5/1"

PIEDRAS DEL BRUC 126 - 127

66,5 x 32/3 · 26,5" x 12,5/1"

| | |
|-------------------|-----------|
| NATUR TRANSIT 2.0 | 132 - 135 |
| PIRINEOS | 128 - 129 |

32 x 32/3 · 12,5" x 12,5/1"

| | |
|-------|-----------|
| RETRO | 158 - 159 |
|-------|-----------|

REMATE ANGULAR ANGULAR REMAT



20 x 90/2,6 · 8" x 35,4/1"
20 x 45/2,6 · 8" x 17,7/1"

| | |
|------------|-----------|
| NATUR TECH | 136 - 137 |
|------------|-----------|

PELDAÑO RECTO STRAIGHT STEP



150 x 33/3 · 60" x 13/1"

| | |
|----------|-----------|
| SHERWOOD | 142 - 145 |
| ZERMATT | 146 - 147 |

120 x 33/3 · 48" x 13/1"

| | |
|---------------|-----------|
| ALMA | 110 - 111 |
| HERITAGE CLAY | 84 - 95 |
| LIMESTONE | 116 - 117 |
| ORION | 108 - 109 |
| SARSEN STONE | 96 - 107 |
| SHERWOOD | 142 - 145 |
| ZERMATT | 146 - 147 |

60 x 33/3 · 23,6" x 13/1"

| | |
|---------------|-----------|
| ALMA | 110 - 111 |
| LIMESTONE | 116 - 117 |
| HERITAGE CLAY | 84 - 95 |
| SARSEN STONE | 96 - 107 |
| SHERWOOD | 142 - 145 |
| ORION | 108 - 109 |
| ZERMATT | 146 - 147 |

45 x 32/3 · 17,7" x 12,5/1"

| | |
|-------|---------|
| UNIKA | 52 - 55 |
|-------|---------|

PELD. RECT. CON GOTERÓN STRAIGHT STEP WITH DRIP EDGE



61,3 x 32/3 · 24" x 12,5/1"

| | |
|--------|-----------|
| ARTIES | 162 - 169 |
| SAONA | 172 - 175 |

33,3 x 33,3/3 · 13,1" x 12,5/1"

| | |
|--------|-----------|
| CERLER | 178 - 181 |
|--------|-----------|

CANALETAS DRAINAGE CHANNELS



| | |
|-------------------|-----------|
| NATUR TRANSIT 2.0 | 132 - 135 |
|-------------------|-----------|

PZS. PODOTÁCTILES TACTILE TILES



| | |
|-------------------|-----------|
| NATUR TRANSIT 2.0 | 132 - 135 |
|-------------------|-----------|

PELDAÑO CURVO CURVED STEP



60 x 33/4 · 23,6" x 13/1,5"

| | |
|---------|---------|
| COTTAGE | 30 - 31 |
|---------|---------|

45 x 33/4 · 17,7" x 13/1,5"

| | |
|--------|---------|
| ARGILE | 44 - 45 |
| FUEGO | 34 - 35 |
| LANDS | 22 - 29 |

36 x 33/4 · 14" x 13/1,5"

| | |
|-------------------|-----------|
| BOSTON | 64 - 65 |
| COTTO NATURE | 70 - 73 |
| NATUR TRANSIT 2.0 | 132 - 135 |
| PIEMONTE | 74 - 77 |

33,3 x 33,3/4 · 13" x 13/1,5"

| | |
|---------|-----------|
| TOSCANA | 182 - 187 |
|---------|-----------|

30 x 33/4 · 11,8" x 13/1,5"

| | |
|--------------|---------|
| COTTO NATURE | 70 - 73 |
| TECH LAND | 78 - 79 |

22,5 x 33/4 · 8,8" x 13/1,5"

| | |
|-------------------|-----------|
| BOSTON | 64 - 65 |
| D'ANTICATTO | 58 - 59 |
| NATUR TRANSIT 2.0 | 132 - 135 |
| TECH GEO | 130 - 131 |

VIERTEAGUAS GUTTER



| | |
|-------------------|-----------|
| BOSTON | 64 - 65 |
| CERLER | 178 - 181 |
| COTTO NATURE | 70 - 71 |
| FUEGO | 34 - 35 |
| LIMESTONE | 116 - 117 |
| NATUR 2.0 TRANSIT | 132 - 135 |
| TECH-LAND | 78 - 79 |
| TEMPO | 234 - 237 |
| TOSCANA | 182 - 187 |

PASAMANOS HANDRAILS



| | |
|---------|-----------|
| CERLER | 178 - 181 |
| TOSCANA | 182 - 187 |

BORDE PISCINA POOL EDGE



| | |
|------------------|-----------|
| ARTIES | 162 - 169 |
| HERITAGE CLAY | 84 - 95 |
| ORION | 108 - 109 |
| PIEDRAS DEL BRUC | 126 - 127 |
| PIRINEOS | 128 - 129 |
| POSETS | 122 - 125 |
| SAONA | 172 - 175 |
| SARSEN STONE | 96 - 107 |
| TECH LAND | 78 - 79 |

DESBORDANTE OVERFLOW

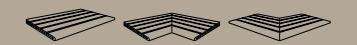

| | |
|------------------|-----------|
| ALPES | 118 - 119 |
| ARTIES | 162 - 169 |
| HERITAGE CLAY | 84 - 95 |
| ORION | 108 - 109 |
| PIEDRAS DEL BRUC | 126 - 127 |
| SAONA | 172 - 175 |
| SARSEN STONE | 96 - 107 |

REJILLA GRATTING



| | |
|------------------|-----------|
| ALPES | 118 - 119 |
| ARTIES | 162 - 169 |
| HERITAGE CLAY | 84 - 95 |
| ORION | 108 - 109 |
| PIEDRAS DEL BRUC | 126 - 127 |
| SAONA | 172 - 175 |
| SARSEN STONE | 96 - 107 |

PZS. ESPECIALES SPECIAL PIECES CUBRECANTO, MEDIA CAÑA Y COMPLEMENTOS



| | |
|-------------------|-----------|
| ARTIES | 162 - 169 |
| HERITAGE CLAY | 84 - 95 |
| NATUR TRANSIT 2.0 | 132 - 135 |
| ORION | 108 - 109 |
| POOL | 224 - 225 |
| SAONA | 172 - 175 |
| SARSEN STONE | 96 - 107 |

UNA VISIÓN INTEGRAL DE LOS ESPACIOS DONDE LA CERÁMICA REDEFINE EL DISEÑO Y LA FUNCIONALIDAD.

A COMPREHENSIVE VIEW OF THE SPACES WHERE CERAMICS REDEFINE DESIGN AND FUNCTIONALITY.

UNE VISION GLOBALE DES ESPACES OÙ LA CÉRAMIQUE REDÉFINIT LE DESIGN ET LA FONCTIONNALITÉ.

REVESTIMIENTOS
PASTA BLANCA
WALL TILES OF WHITE BODY

DORMITORIO
BEDROOM

BAÑO
BATHROOM

COCINA
KITCHEN

PAVIMENTOS
ANTIDESLIZANTES
CLASE III - R11
ANTISLIP FLOORS
CLASS III - R11

SISTEMAS
DE CORONACIÓN
DE PISCINAS
ANGULAR STEP

PORCELÁNICO PARA
VASO DE PISCINA
SWIMMING POOL LINING

PELDAÑOS
STEPS

SUELO PORCELÁNICO CLASE I - R9
PORCELAIN FLOOR TILE CLASS I - R9

TERRAZA
TERRACE

SALÓN
LIVINGROOM

Usos y aplicaciones de la cerámica

USES AND APPLICATIONS OF TILES
USAGES ET APPLICATIONS DE LA CÉRAMIQUE

Simbología

SYMBOLOLOGY · SIMBOLOGIE

| | | | |
|--|--|--|---|
| P PORCELÁNICO Porcelain Tile Grès cérame | SIN MANTENIMIENTO No maintenance Sans entretien | SUPERFICIE MATE Matt surface Surface mate | ENMALLADO On a mesh Céramique en treillis |
| PE GRES EXTRUSIONADO PORCELÁNICO Porcelain extruded tile Grès cérame extrudé | RESISTENCIA AL RAYADO Scratch resistance Résistance aux rayures | SUPERFICIE SATINADO Satin finish Surface satinée | VOLUMEN Volume Volume |
| PAVIMENTO DE INTERIOR Indoor floor tiles Revêtement de sol intérieur | RESISTENTE AL DESGASTE Wear resistance Résistant à l'usure | SUPERFICIE BRILLO Surface brightness / glossy Surface brillante | DESTONIFICADO ARMONIOSO Controlled destonification Détonification harmonieuse |
| PAVIMENTO EXTERIOR Outdoor floor tile Revêtement de sol extérieur | RESISTENTE A LA HELADA Frost proof Résistant au gel | MODULARIDAD Modularity Modularité | BORDES Y SUPERFICIE IRREGULAR Irregular Edges and Surface Bords et surface irréguliers |
| REVESTIMIENTO Wall tile Revêtement | RESISTENCIA A ÁCIDOS Y BASES Resistance to acids and bases Résistance aux acides et aux bases | RECTIFICADO Rectified Rectifié | NÚMERO DE GRÁFICAS Number of graphs Nombre de graphiques |
| SPECIAL ORDER (MINIMUM 4 WEEKS LEAD TIME) BAJO PEDIDO (MÍNIMO 4 SEMANAS) SUR COMMANDE (DÉLAI MINIMUM DE 4 SEMAINES) | SERIES NOVEDADES New series Nouvelles séries | | |

CARACTERÍSTICAS TÉCNICAS / Technical characteristics / Caractéristiques techniques

| | | | |
|--|---|---|--|
| FUERZA DE ROTURA Breaking strength Résistance à la rupture | ANTIDESLIZANTE TORTUS Antislip Antidérapant | MANCHAS Staining Taches | ABSORCIÓN Water absorption Absorption |
| CARGA DE ROTURA Breaking Charge de rupture | ANTIDESLIZANTE UNE-EN-16165 ANEXO C-B Antislip Antidérapant | DILATACIÓN Dilatation Dilatation | ESPESOR Thickness Épaisseur |
| RESISTE EL DESGASTE Wear resistance Résistant à l'usure | ANTIDESLIZANTE UNE-EN-16165 ANEXO A Antislip Antidérapant | RESISTE LA FLEXIÓN Bending resistance Résiste à la flexion | ANTIHIELO Antifreeze Antigel |
| RESISTE EL RAYADO Scratch resistance Résistance aux rayures | | | |

TIPOLOGÍA DE FABRICACIÓN / Type of manufacture / Typologie de fabrication

| | | |
|--|---|--|
| EXTRUSIONADO PORCELÁNICO EXTRUDED PORCELAIN TILE EXTRUDÉ PORCELANIQUE | PORCELÁNICO PORCELAIN TILE Porcelain tile Grès cérame | PRODUCTO SE VENDE POR PIEZA This product is sold per piece Produit vendu à la pièce |
| PORCELÁNICO RECTIFICADO RECTIFIED PORCELAIN TILE GRÈS CÉRAMÉ RECTIFIÉ | PASTA BLANCA White body Pâte blanche | PRODUCTO SE VENDE POR M2 This product is sold per sqm Produit vendu au m ² |
| | ANTIBACTERIANO Antibacterial Antibactérien | GARANTÍA DE CALIDAD QUALITY GUARANTEE GARANTIE DE QUALITÉ |
| | | MADE IN SPAIN |

Uso de Catálogo

USE OF CATALOGUE · UTILISATION DU CATALOGUE



| | | |
|---|---|--|
| 1 NOMBRE DE LA SERIE Name of the serie Nom de la série | 7 AMBIENTES DE LA SERIE Environments series Ambiances de la série | 13 FORMATOS DISPONIBLES Available sizes Formats disponibles |
| 2 SERIES NOVEDADES New series Nouvelles séries | 8 REFERENCIA DEL AMBIENTE Environment reference Référence de l'environnement | 45 x 45 TAMAÑO EN CENTÍMETROS Size centimeters Dimensions en centimètres |
| 3 ANTIDESLIZAMIENTO Antislip Antidérapant | 9 PIEZAS ESPECIALES Special pieces Pièces spéciales | (G 73) CÓDIGO DE PRECIO Price code Code de prix |
| 4 CARACTERÍSTICAS TÉCNICAS Technical characteristics Caractéristiques techniques | 10 NÚMERO DE PÁGINA Page number Numéro de page | 17,7" x 17,7" TAMAÑO EN PULGADAS Size inches Dimensions en pouces |
| 5 COLORES DISPONIBLES Color typology Couleur de typologie | 11 PIEZAS DE LA SERIE Serie pieces Pièces de la série | 12 mm. ESPESOR Thickness Épaisseur |
| 6 QR DE LA SERIE QR of the serie QR de la série | 12 NÚMERO DE CARAS O DISEÑOS DISPONIBLES Page number Numéro de page | 14 TIPOLOGÍA DE FABRICACIÓN Type of manufacture Typologie de fabrication |



Pavimento

floor tiles



COLECCIONES · COLLECTIONS

BARRO · COTTO

| | |
|--------------|---------|
| AMERICAN | 66 - 67 |
| ARGILE | 44 - 49 |
| BOSTON | 64 - 65 |
| BOSTON BRICK | 68 - 69 |
| COTTAGE | 30 - 33 |
| COTTO BRICK | 50 - 51 |
| COTTO NATURE | 70 - 73 |
| D'ANTICATTO | 58 - 63 |
| FUEGO | 34 - 43 |
| LANDS | 22 - 29 |
| PIEMONTE | 74 - 77 |
| TECH-LAND | 78 - 83 |
| UNIKA | 52 - 57 |

PIEDRA · STONE

| | |
|-------------------|-----------|
| ALMA | 110 - 111 |
| ALPES | 118 - 119 |
| ANIMA | 112 - 113 |
| ANIMA ANTISLIP | 114 - 115 |
| HERITAGE CLAY | 84 - 95 |
| LIMESTONE | 116 - 117 |
| NATUR TRANSIT 2.0 | 132 - 135 |
| OLIMPO | 120 - 121 |
| ORION | 108 - 109 |
| PIEDRAS DEL BRUC | 126 - 127 |
| PIRINEOS | 128 - 129 |
| POSETS | 122 - 123 |
| POSETS ANTISLIP | 124 - 125 |
| SARSEN STONE | 96 - 107 |
| TECH-GEO | 130 - 131 |

MADERA · WOOD

| | |
|---------------------|-----------|
| ALQUÉZAR | 154 - 155 |
| BOTANICA | 148 - 149 |
| NATURA | 150 - 153 |
| NATUR-TECH | 136 - 137 |
| PARK | 156 - 157 |
| RETRO | 158 - 159 |
| SHERWOOD | 138 - 145 |
| ZERMATT | 146 - 147 |
| PROJECT ZERO | |
| ARTIES | 162 - 169 |
| CERLER | 176 - 181 |
| TOSCANA | 182 - 187 |
| SAONA | 170 - 175 |





Lands Loees 45x45 - Lands Loees 22,5x45 - Lands Loees 22,5x22,5



LANDS, la materia del barro reinterpretada con elegancia actual.
LANDS, the essence of clay reinterpreted with contemporary elegance.

LANDS



NATUCER
cerámica natural

NEW
2026

LANDS

LANDS reinterpreta el barro como materia esencial desde una mirada actual y refinada. Sus superficies ponen en valor lo artesanal y lo natural, transformando la tradición en un lenguaje contemporáneo lleno de sobriedad y carácter. Una colección que aporta autenticidad y equilibrio a espacios con identidad propia.

LANDS reinterprets clay as an essential material through a refined, contemporary perspective. Its surfaces highlight the handcrafted and the natural, transforming tradition into a modern language defined by sobriety and character. A collection that brings authenticity and balance to spaces with their own identity.

NATUCER
cerámica natural



Pav. / Floor: Lands Loes Antislip 45x45 - Peldaño Curvo Lands Loes Antislip 45x33/4
Vaso Piscina / Pool Basin: Square Fiorano 15x15



Pav. / Floor: Lands Desert Antislip 45x45 - Lands Desert Antislip 22,5x45 - Lands Desert Antislip 22,5x22,5 - Peldaño Curvo Lands Desert Antislip 45x33/4



Pav. / Floor: Lands Loees Antislip 45x45 - Lands Loees Antislip 22,5x45 - Lands Loees Antislip 22,5x22,5 - Peldaño Curvo Lands Loees Antislip 45x33/4



LANDS KAOLIN
LANDS KAOLIN ANTISLIP
* 60 x 60 - 23,6" x 23,6" - CLASE I - R9
* STAR & CROSS 15,5 x 15,5 - 6" x 6" - CLASE II - R10



LANDS DESERT
LANDS DESERT ANTISLIP
* 60 x 60 - 23,6" x 23,6" - CLASE I - R9
* STAR & CROSS 15,5 x 15,5 - 6" x 6" - CLASE II - R10



LANDS JASPER
LANDS JASPER ANTISLIP
* 60 x 60 - 23,6" x 23,6" - CLASE I - R9
* STAR & CROSS 15,5 x 15,5 - 6" x 6" - CLASE II - R10



LANDS LOEES
LANDS LOEES ANTISLIP
* 60 x 60 - 23,6" x 23,6" - CLASE I - R9
* STAR & CROSS 15,5 x 15,5 - 6" x 6" - CLASE II - R10

* **Gráfica diferente + Bordes irregulares**
Different graphics + Irregular Edges

* 24
11 x 22,5 (G 80)
11 x 22,5 (G 80) ANTISLIP
4,3" x 8,8"
± 10 mm.



Pav. / Floor: Lands Loees Antislip 11x22,5 - Peldaño Curvo Lands Loees Antislip 45x33/4

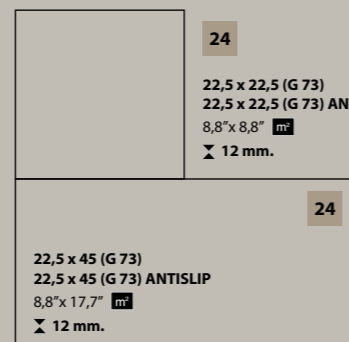
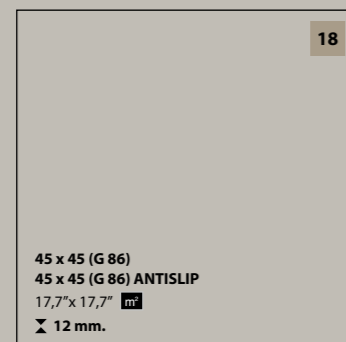

PIEZAS ESPECIALES - SPECIAL PIECES

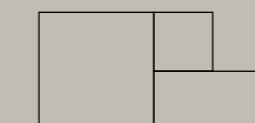
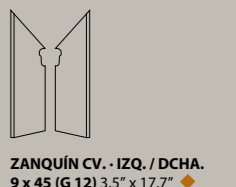
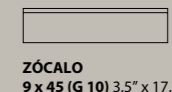
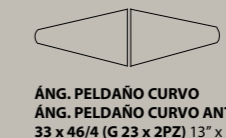

Cada caja contiene:
3 piezas de 45x45
3 piezas de 22,5x45
3 piezas de 22,5x22,5

Each box contains:
3 pieces 17,7"x17,7"
3 pieces 8,8"x17,7"
3 pieces 8,8"x8,8"



Pav. / Floor: Lands Kaolin 60x60 - Peldaño Curvo Lands Kaolin 45x33/4



Pav. / Floor: Lands Desert 60x60



LANDS KAOLIN 60 x 60 (G 79) 23,6" x 23,6" **m²** 18
x 12 mm.



LANDS LOEES 60 x 60 (G 79) 23,6" x 23,6" **m²** 18
x 12 mm.



LANDS ANDES 60 x 60 (G 76) 23,6" x 23,6" **m²** 6
x 12 mm.



LANDS DESERT 60 x 60 (G 79) 23,6" x 23,6" **m²** 18
x 12 mm.



LANDS JASPER 60 x 60 (G 79) 23,6" x 23,6" **m²** 18
x 12 mm.



LANDS ANDES 60 x 60 (G 76) 23,6" x 23,6" **m²** 6
x 12 mm.

COTTAGE

EXTRUSIONADO PORCELÁNICO
EXTRUDED PORCELAIN TILE

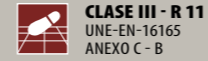

Pav. / Floor: Cottage Sun Antislip 60x60 - Peldaño Curvo Cottage Sun Antislip 60x33/4 - Ángulo Peldaño Curvo Cottage Sun Antislip 33x46/4
Rev. / Wall: Cross Cottage Sun 15,5x15,5 - Taco Cottage Lacock 4x4



Pav. / Floor: Cottage Dune Antislip 60x60
Peldaño Curvo Cottage Dune Antislip 60x33/4



Pav. / Floor: Cottage Mud 60x60
Rev. / Wall: Star Cottage Mud 15,5x15,5 - Cross Cottage Mud 15,5x15,5 - Austral Beige 40x60



COTTAGE SUN
COTTAGE SUN ANTISLIP
* STAR & CROSS 15,5 x 15,5 - 6" x 6" - CLASE II - R10



COTTAGE DUNE
COTTAGE DUNE ANTISLIP
* STAR & CROSS 15,5 x 15,5 - 6" x 6" - CLASE II - R10



COTTAGE MUD
COTTAGE MUD ANTISLIP
* STAR & CROSS 15,5 x 15,5 - 6" x 6" - CLASE II - R10



COTTAGE VOLCANO
COTTAGE VOLCANO ANTISLIP
* STAR & CROSS 15,5 x 15,5 - 6" x 6" - CLASE II - R10

PIEZAS ESPECIALES
SPECIAL PIECES

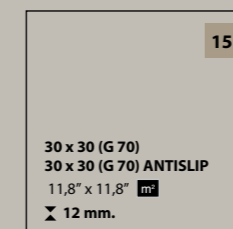
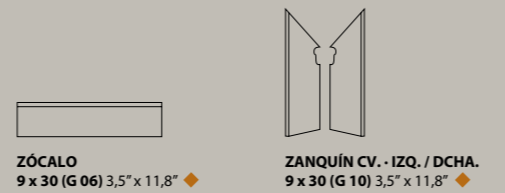
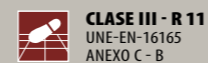

COTTAGE

EXTRUSIONADO PORCELÁNICO
EXTRUDED PORCELAIN TILE

CLASE I - R 9
UNE-EN-16165
ANEXO C - B



Pav. / Floor: Cottage Mud 60x60 - Cottage Mud 30x30



COTTAGE BOURTON 60 x 60 (G 76) 23,6" x 23,6" m^2 4
X 12 mm.



COTTAGE YORK 60 x 60 (G 76) 23,6" x 23,6" m^2 4
X 12 mm.



COTTAGE CASTLE 60 x 60 (G 76) 23,6" x 23,6" m^2 4
X 12 mm.



COTTAGE LACOCK 60 x 60 (G 76) 23,6" x 23,6" m^2 4
X 12 mm.

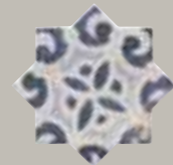

4

STAR COTTAGE BOURTON
15,5 x 15,5 (G 84) 6" x 6" m^2



TACO COTTAGE BOURTON
4 x 4 (G 01) 1,5" x 1,5" m^2



4

STAR COTTAGE CASTLE
15,5 x 15,5 (G 84) 6" x 6" m^2



TACO COTTAGE CASTLE
4 x 4 (G 01) 1,5" x 1,5" m^2



4

STAR COTTAGE YORK
15,5 x 15,5 (G 84) 6" x 6" m^2



TACO COTTAGE YORK
4 x 4 (G 01) 1,5" x 1,5" m^2



4

STAR COTTAGE LACOCK
15,5 x 15,5 (G 84) 6" x 6" m^2



TACO COTTAGE LACOCK
4 x 4 (G 01) 1,5" x 1,5" m^2



Pav. / Floor: Cottage Volcano 60x60 - Cottage Volcano 30x30



Pav. / Floor: Fuego Teja 45x45 · Fuego Teja 22,5x22,5 · Peldaño Curvo Fuego Teja 45x33/4



Pav. / Floor: Fuego Natural 45x45
Rev. / Wall: Fuego Natural 45x45



Pav. / Floor: Fuego Antic 45x45 · Fuego Antic Brick 6,5x25 · Peldaño Curvo Fuego Antic 45x33/4 · Ángulo Peldaño Curvo Fuego Antic 33x46/4 · Zócalo Fuego Antic 9x45



FUEGO ANTIC
FUEGO ANTIC ANTISLIP



FUEGO TEJA
FUEGO ANTIC ANTISLIP



FUEGO NATURAL
FUEGO ANTIC ANTISLIP



FUEGO BLANCO

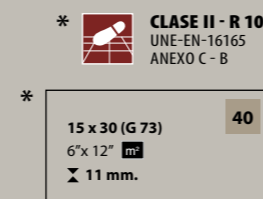
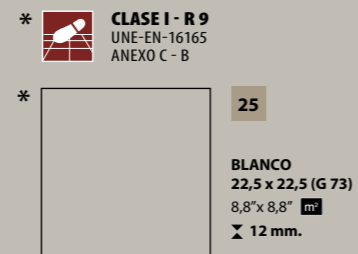
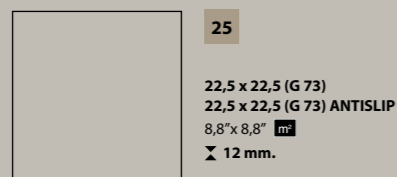
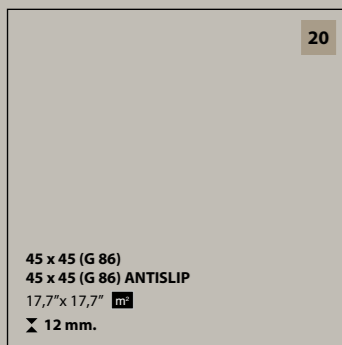

PIEZAS ESPECIALES · SPECIAL PIECES
Disponible en NATURAL, ANTIC y TEJA · Available in NATURAL, ANTIC & TEJA



PELDAÑO CURVO
PELDAÑO CURVO ANTISLIP
45 x 33/4 (G 87) 17,7" x 13"/1,5" ◆



VIERTEAGUAS ANTISLIP
15 x 22,5/4 (G 10) 5,9" x 8,8"/1,5" ◆



ÁNG. PELDAÑO CURVO
ÁNG. PELDAÑO CURVO ANTISLIP
33 x 46/4 (G 23 x 2PZ) 13" x 18"/1,5" ◆



ZÓCALO
9 x 45 (G 10) 3,5" x 17,7" ◆

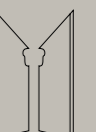

ZANQUÍN CV. · IZQ. / DCHA.
9 x 45 (G 12) 3,5" x 17,7" ◆

FUEGO

EXTRUSIONADO PORCELÁNICO
EXTRUDED PORCELAIN TILE

CLASE II - R 10
UNE-EN-16165
ANEXO C - B



Rev. / Wall: Fuego Blanco 22,5x22,5 - Fuego Natural Brick 6,5x25 - Fuego Natural 45x45
Pav. / Floor: Fuego Era 22,5x22,5 - Peldaño Curvo Fuego Natural 45x33/4 - Ángulo Peldaño Curvo Fuego Natural 33x46/4



FUEGO BLANCO



FUEGO NATURAL



FUEGO ANTIC



FUEGO TEJA



FUEGO MIX



33

BRICK
6,5 x 25 (G 39) 2,5" x 10" m
x 11 mm.



Pav. / Floor: Fuego Natural Antislip 45x45 - Peldaño Curvo Fuego Natural Antislip 45x33/4

FUEGO

EXTRUSIONADO PORCELÁNICO
EXTRUDED PORCELAIN TILE

CLASE II - R 10
UNE-EN-16165
ANEXO C - B

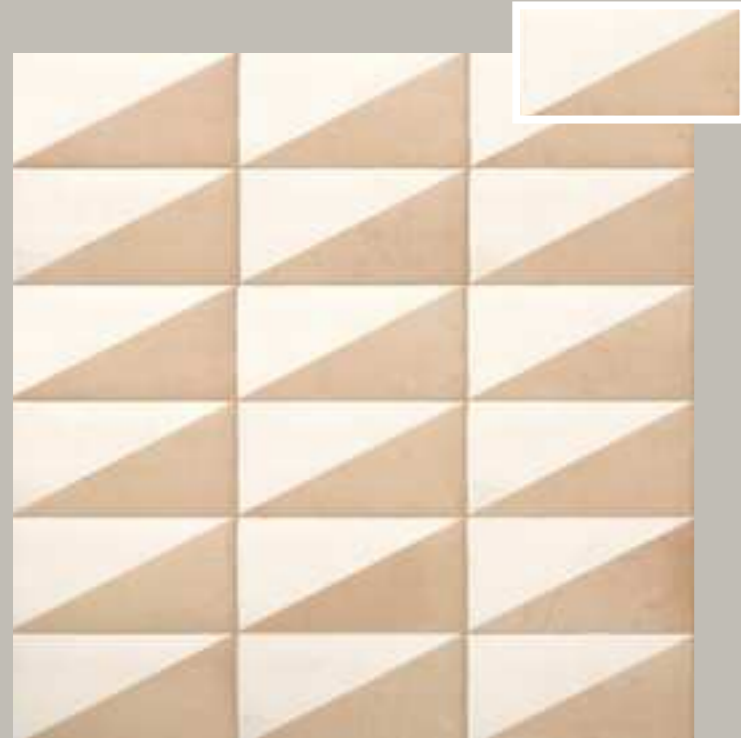

FUEGO LINAJE 15 x 30 (G 73) - 6" x 12" **m²**
x 11 mm.

16

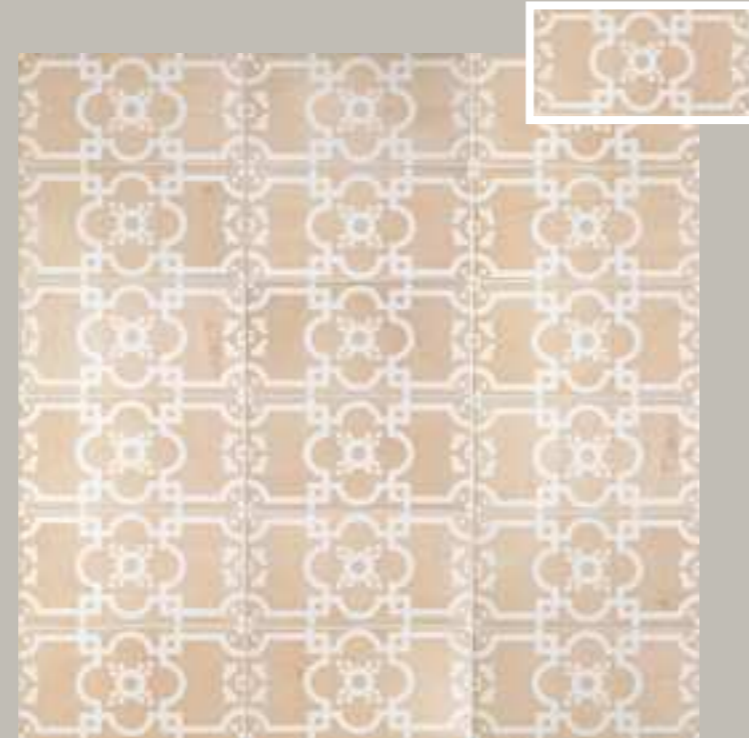

FUEGO HERENCIA 15 x 30 (G 73) - 6" x 12" **m²**
x 11 mm.

16

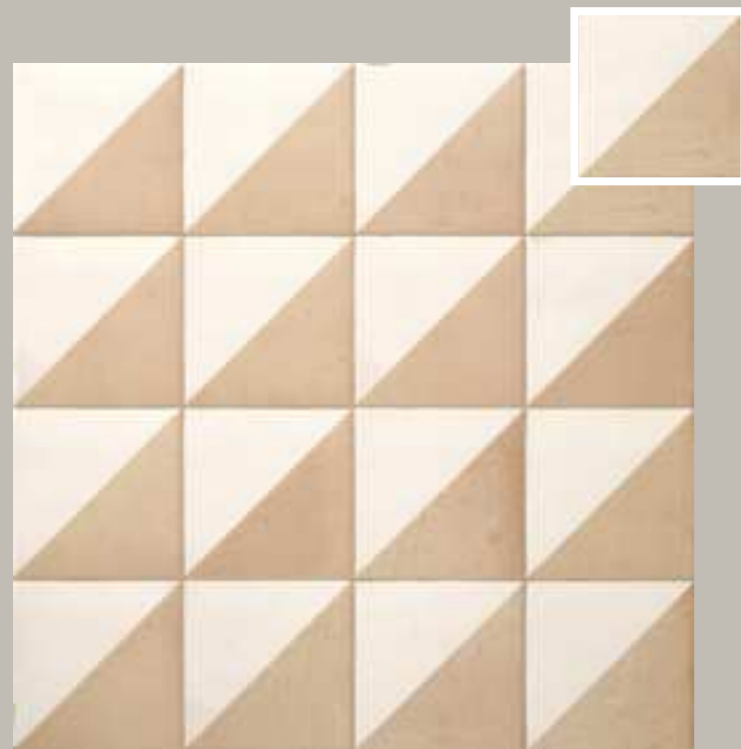

FUEGO LINAJE 22,5 x 22,5 (G 86) - 8,8" x 8,8" **m²**
x 12 mm.

16



FUEGO ERA 22,5 x 22,5 (G 86) - 8,8" x 8,8" **m²**
x 12 mm.

16



Rev. / Wall: Fuego Era 22,5x22,5 - Fuego Natural 15x30 - Fuego Natural Brick 6,5x25
Pav. / Floor: Fuego Natural 45x45 - Fuego Natural 22,5x22,5



Rev. / Wall: Fuego Raices 22,5x22,5 · Fuego Antic 15x30 · Peldaño Curvo Fuego Antic 45x33/4



Pav. / Floor: Fuego Huella 22,5x22,5 · Zócalo Fuego Natural 9x45



FUEGO HUELLA 22,5 x 22,5 (G 86) · 8,8" x 8,8" **m**
Σ 12 mm.

16



FUEGO RAICES 22,5 x 22,5 (G 86) · 8,8" x 8,8" **m**
Σ 12 mm.

16

FUEGO

EXTRUSIONADO PORCELÁNICO
EXTRUDED PORCELAIN TILE

CLASE II - R 10
UNE-EN-16165
ANEXO C - B

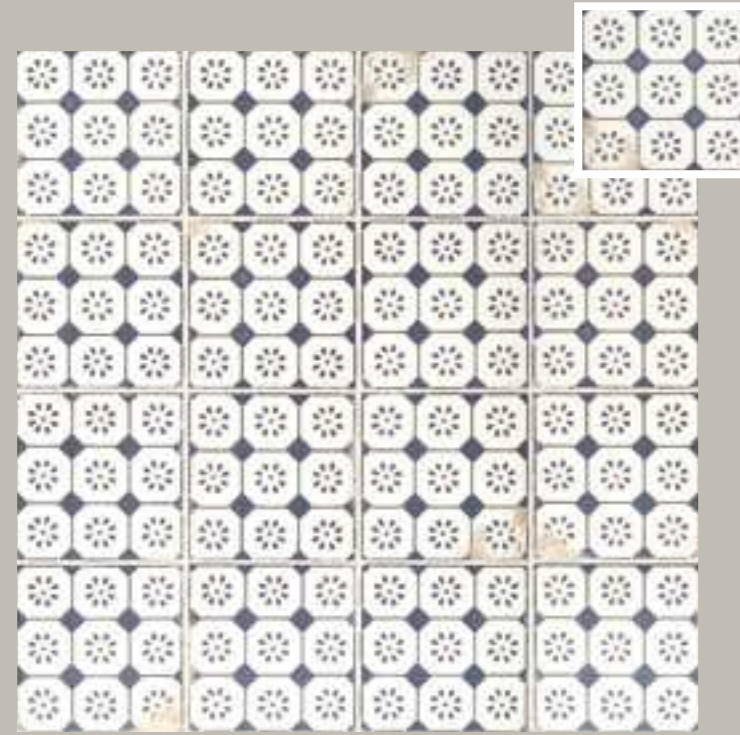

FUEGO TESSELAR 22,5 x 22,5 (G 86) · 8,8" x 8,8" m²
Σ 12 mm. **16**



FUEGO ÉPOCA MIX 22,5 x 22,5 (G 86) · 8,8" x 8,8" m²
Σ 12 mm.
(MIX DE: FUEGO TESSELAR, FUEGO RAICES, FUEGO LEGADO, FUEGO ESPLENDOR Y FUEGO HUELLA)



FUEGO ESPLENDOR 22,5 x 22,5 (G 86) · 8,8" x 8,8" m²
Σ 12 mm. **16**



FUEGO LEGADO 22,5 x 22,5 (G 86) · 8,8" x 8,8" m²
Σ 12 mm. **16**



Rev. / Wall: Fuego Tesselar 22,5x22,5 · Fuego Blanco 22,5x22,5
Pav. / Floor: Fuego Natural 15x30

ARGILE

EXTRUSIONADO PORCELÁNICO
EXTRUDED PORCELAIN TILE

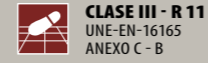

Pav. / Floor: Argile Ferrara 45x45 - Arrow Argile Bianco 7,4x48
Rev. / Wall: Argile Bianco 15x15



Pav. / Floor: Argile Ferrara 45x45 - Square Argile Bianco 15x15



ARGILE FERRARA
ARGILE FERRARA ANTISLIP



ARGILE VERONA
ARGILE VERONA ANTISLIP



ARGILE PALERMO
ARGILE PALERMO ANTISLIP



Pav. / Floor: Argile Palermo Antislip 45x45 - Argile Palermo Antislip 22,5x45
Argile Palermo Antislip 22,5x22,5 - Peldaño Curvo Argile Palermo Antislip 45x33/4

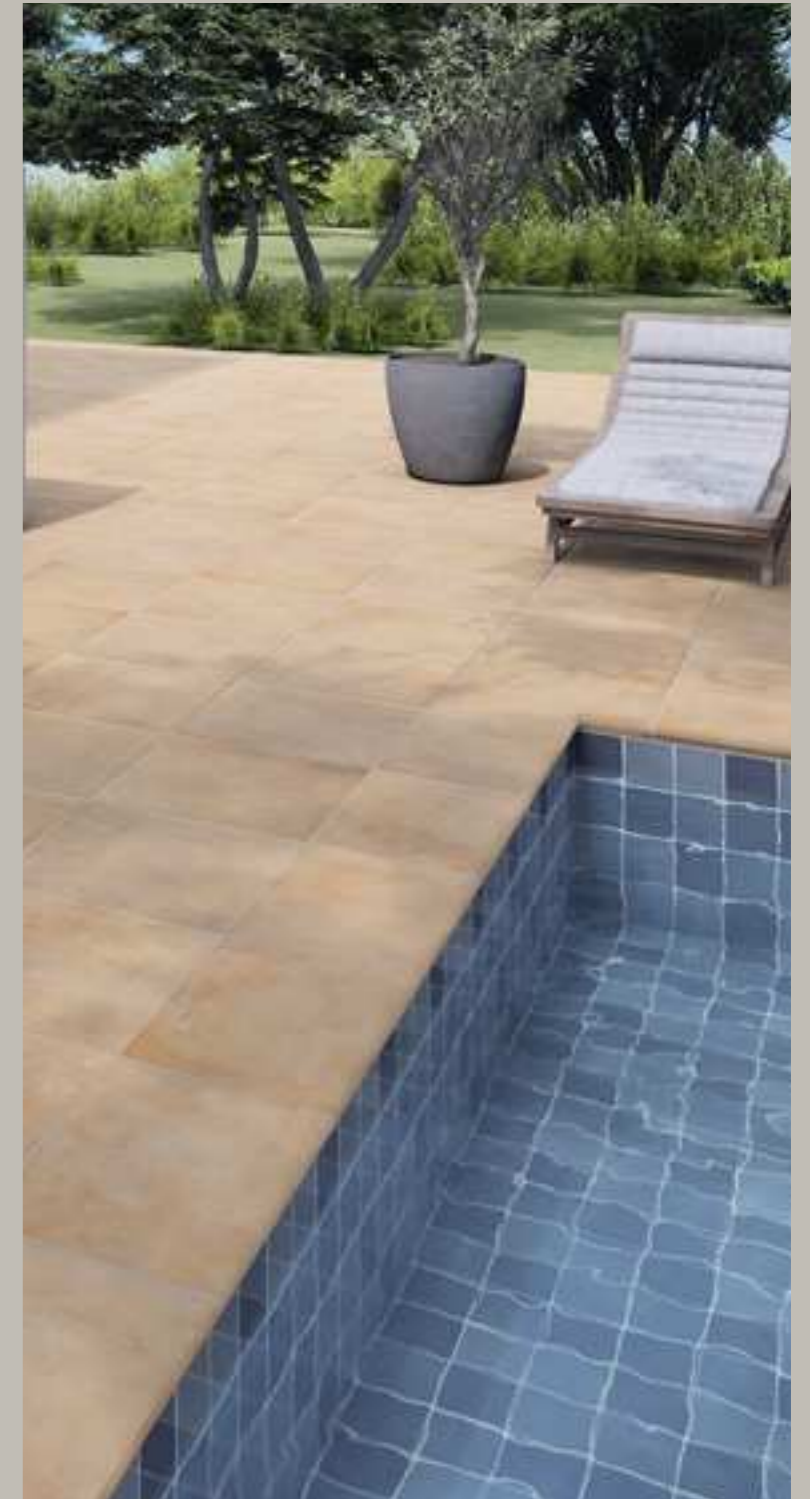

Pav. / Floor: Argile Verona Antislip 45x45 - Peldaño Curvo Argile Verona Antislip 45x33/4
Vaso Piscina / Pool Basin: Pool Porc. Indigo Antislip Enm. 30,5x30,5

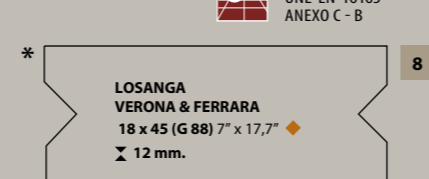
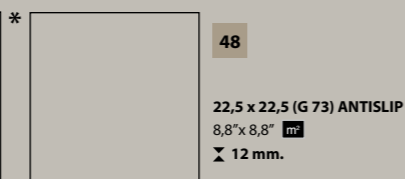
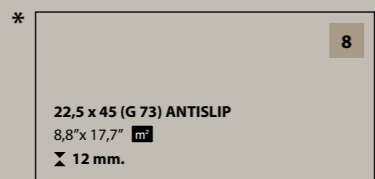
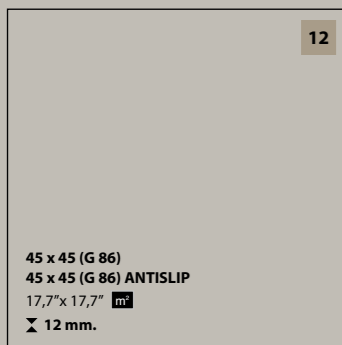

PIEZAS ESPECIALES - SPECIAL PIECES



PELDAÑO CURVO ANTISLIP
45 x 33/4 (G 87) 17,7" x 13"/1,5"

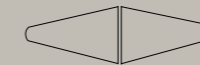

ÁNG. PELDAÑO CURVO ANTISLIP
33 x 46/4 (G 23 x 2PZ) 13" x 18"/1,5"



ZÓCALO
9 x 45 (G 10) 3,5" x 17,7"

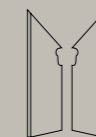

ZANQUÍN CV. - IZQ. / DCHA.
9 x 45 (G 12) 3,5" x 17,7"



MÓDULO ANTISLIP (G 76) m^2
packing: 1,063 m^2 /caja

Cada caja contiene:
3 piezas de 45x45
3 piezas de 22,5x45
3 piezas de 22,5x22,5

Each box contains:
3 pieces 17,7"x17,7"
3 pieces 8,8"x17,7"
3 pieces 8,8"x8,8"

ARGILE

EXTRUSIONADO PORCELÁNICO
EXTRUDED PORCELAIN TILE

SPECIAL ORDER
BAJO PEDIDO

CLASE I - R 9
UNE-EN-16165
ANEXO C - B



MATE
MATT

BRILLO
GLOSS



Rev. / Wall: **Arrow Argile Verde 7,4x48**



Pav. / Floor: **Argile Ferrara Antislip 45x45 - Losagna Argile Ferrara 18x45
Star Argile Aquamarina 18x18 - Taco Argile Aquamarina 4x4**



Pav. / Floor: **Argile Verona Antislip 22,5x45 - Taco Argile Blu 15x15**



Pav. y Rev. / Floor & Wall: **Arrow Argile Cotto 7,4x48 - Arrow Argile Bianco 7,4x48**



SQUARE ARGILE VERDE 15 x 15 (G 72) 6" x 6" m²
TACO ARGILE VERDE 15 x 15 (G 07) 6" x 6" ◆
⊗ 10 mm.



SQUARE ARGILE AQUAMARINA 15 x 15 (G 72) 6" x 6" m²
TACO ARGILE AQUAMARINA 15 x 15 (G 07) 6" x 6" ◆
⊗ 10 mm.



SQUARE ARGILE BLU 15 x 15 (G 72) 6" x 6" m²
TACO ARGILE BLU 15 x 15 (G 07) 6" x 6" ◆
⊗ 10 mm.



SQUARE ARGILE BIANCO 15 x 15 (G 72) 6" x 6" m²
TACO ARGILE BIANCO 15 x 15 (G 07) 6" x 6" ◆
⊗ 10 mm.



CROSS COTTO 18 x 18 (G 84) 7" x 7" m²
CRUZ COTTO 18 x 18 (G 75) 7" x 7" ◆
⊗ 10 mm.



PIEZAS ESPECIALES · SPECIAL PIECES
Disponibile en PALERMO, VERONA y FERRARA
Available in all colors PALERMO, VERONA & FERRARA



ARROW ARGILE VERDE 7,4 x 48 (G 83) 3" x 19" m²
LANZA ARGILE VERDE 7,4 x 48 (G 09) 3" x 19" ◆
⊗ 10 mm.



ARROW ARGILE BLU 7,4 x 48 (G 83) 3" x 19" m²
LANZA ARGILE BLU 7,4 x 48 (G 09) 3" x 19" ◆
⊗ 10 mm.



ARROW ARGILE BIANCO 7,4 x 48 (G 83) 3" x 19" m²
LANZA ARGILE BIANCO 7,4 x 48 (G 09) 3" x 19" ◆
⊗ 10 mm.



ARROW COTTO 7,4 x 48 (G 83) 3" x 19" m²
LANZA COTTO 7,4 x 48 (G 09) 3" x 19" ◆
⊗ 10 mm.

DEMI-BULLNOSE
1,5 x 30 (G 07) 0,6" x 11,8" ◆



TACO ARGILE VERDE 4 x 4 (G 01) 2" x 2" ◆
⊗ 10 mm.



TACO ARGILE AQUAMARINA 4 x 4 (G 01) 2" x 2" ◆
⊗ 10 mm.



TACO ARGILE BLU 4 x 4 (G 01) 2" x 2" ◆
⊗ 10 mm.



TACO ARGILE BIANCO 4 x 4 (G 01) 2" x 2" ◆
⊗ 10 mm.



STAR ARGILE VERDE 18 x 18 (G 84) 7" x 7" m²
ESTRELLA ARGILE VERDE 18 x 18 (G 75) 7" x 7" ◆
⊗ 10 mm.



STAR ARGILE AQUAMARINA 18 x 18 (G 84) 7" x 7" m²
ESTRELLA ARGILE AQUAMARINA 18 x 18 (G 75) 7" x 7" ◆
⊗ 10 mm.

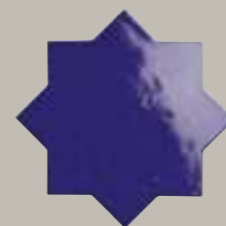

STAR ARGILE BLU 18 x 18 (G 84) 7" x 7" m²
ESTRELLA ARGILE BLU 18 x 18 (G 75) 7" x 7" ◆
⊗ 10 mm.



STAR ARGILE BIANCO 18 x 18 (G 84) 7" x 7" m²
ESTRELLA ARGILE BIANCO 18 x 18 (G 75) 7" x 7" ◆
⊗ 10 mm.



CROSS ARGILE BIANCO 18 x 18 (G 84) 7" x 7" m²
CRUZ ARGILE BIANCO 18 x 18 (G 75) 7" x 7" ◆
⊗ 10 mm.



CROSS FORESTA 18 x 18 (G 84) 7" x 7" m²
CRUZ FORESTA 18 x 18 (G 75) 7" x 7" ◆
⊗ 10 mm.



ARROW FORESTA 7,4 x 48 (G 83) 3" x 19" m²
LANZA FORESTA 7,4 x 48 (G 09) 3" x 19" ◆
⊗ 10 mm.

ARGILE

EXTRUSIONADO PORCELÁNICO
EXTRUDED PORCELAIN TILE

CLASE I - R 9
UNE-EN-16165
ANEXO C - B



Rev. / Wall: **Square Fiorano 15x15**



Pav. / Floor: **Argile Verona 45x45 - Losagna Argile Verona 18x45 - Star Venice 18x18**



Pav. / Floor: **Argile Modena 22,5x22,5**

SATINADO
SATIN



SQUARE FIORANO 15 x 15 (G 72) 6" x 6" m²
X 10 mm.



STAR VENICE A 18 x 18 (G 84) 7" x 7" m²
X 10 mm.



STAR VENICE B 18 x 18 (G 84) 7" x 7" m²
X 10 mm.



STAR VENICE C 18 x 18 (G 84) 7" x 7" m²
X 10 mm.



FRONT FIORANO 15 x 45 (G 72) 6" x 17,7" m²
X 10 mm.



FRONT VENICE 15 x 45 (G 72) 6" x 17,7" m²
X 10 mm.



SQUARE VENICE 15 x 15 (G 72) 6" x 6" m²
X 10 mm.



TACO VENICE 4 x 4 (G 04) 2" x 2" ♦
X 10 mm.



TACO VENICE 5 x 5 (G 04) 2" x 2" ♦
X 10 mm.

MATE
MATT



ARGILE UDINE 22,5 x 22,5 (G 73) 8,8" x 8,8" m²
X 10 mm.

12



ARGILE RAVENNA 22,5 x 22,5 (G 73) 8,8" x 8,8" m²
X 10 mm.

12



ARGILE MODENA 22,5 x 22,5 (G 73) 8,8" x 8,8" m²
X 10 mm.

12

* CLASE II - R 10
UNE-EN-16165
ANEXO C - B

COTTO BRICK

EXTRUSIONADO PORCELÁNICO
EXTRUDED PORCELAIN TILE

CLASE II - R 10
UNE-EN-16165
ANEXO C - B



Pav. / Floor: Cotto Brick Clay 7x60



COTTO BRICK CLEAR 7 x 60 (G 77) 3" x 24" **m²**
6
x 10 mm.



COTTO BRICK SAND 7 x 60 (G 77) 3" x 24" **m²**
6
x 10 mm.

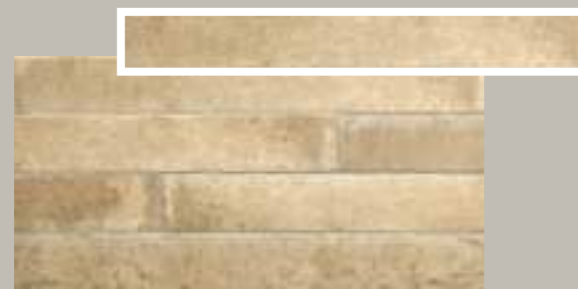

COTTO BRICK LINEN 7 x 60 (G 77) 3" x 24" **m²**
6
x 10 mm.



COTTO BRICK CLAY 7 x 60 (G 77) 3" x 24" **m²**
6
x 10 mm.



Pav. / Floor: Cotto Brick Sand 7x60
Rev. / Wall: Cotto Brick Sand 7x60



Rev. / Wall: **Unika Artico 11x22,5** - **Cross Unika Artico 15,5x15,5** - **Taco Unika Barro 4x4**
Pav. / Floor: **Unika Barro 22,5x45**



Rev. / Wall: **Unika Sage 22,5x45** - **Cross Unika Sage 15,5x15,5** - **Star Unika Sage 15,5x15,5**
Pav. / Floor: **Unika Sage 22,5x45** - **Peldaño Recto Unika Sage 45x32/3** - **Sherwood Birch 20x120**

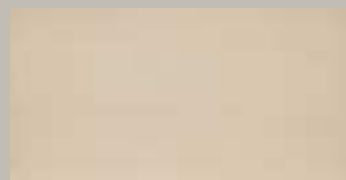

UNIKA TOPO

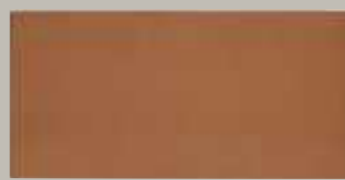

UNIKA BARRO



UNIKA SAGE

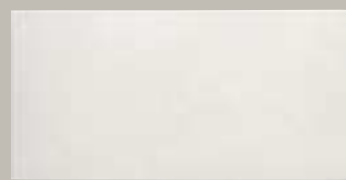

UNIKA ARTICO



UNIKA DENIM

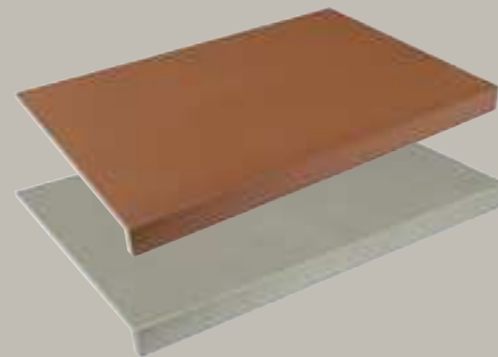

PIEZAS ESPECIALES · SPECIAL PIECES
Disponible en BARRO y SAGE · Available in BARRO & SAGE



PELDAÑO RECTO
45 x 32/3 (G 87) 17,7" x 12,5"/1"

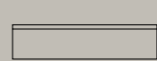

ZÓCALO
9 x 45 (G 10) 3,5" x 17,7"

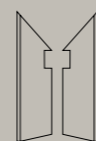

ZANQUÍN RECTO.
IZQ. / DCHA.
9 x 45 (G 12) 3,5" x 17,7"

7

22,5 x 45 (G 68)
8,8" x 17,7" **m²**
± 10 mm.

28

22,5 x 22,5 (G 68)
8,8" x 8,8" **m²**
± 10 mm.

28

11 x 22,5 (G 86)
4,3" x 8,8" **m²**
± 10 mm.



Rev. / Wall: **Unika Topo 11x22,5**
Pav. / Floor: **Cross Unika Topo 15,5x15,5** - **Taco Unika Artico 4x4**



Pav. / Floor: **Taco Unika Denim 4x4** · **Cross Unika Artico 15,5x15,5**
Rev. / Wall: **Unika Denim 11x22,5**



Pav. / Floor: **Cross Unika Sage 15,5x15,5** · **Star Unika Sage 15,5x15,5**



Rev. / Wall: **Cross Unika Barro 15,5x15,5** · **Star Unika Barro 15,5x15,5**
Pav. / Floor: **Unika Barro 22,5x45**



Pav. / Floor: **Cross Unika Topo 15,5x15,5** · **Star Unika Topo 15,5x15,5** · **Unika Topo 22,5x22,5**
Rev. / Wall: **Unika Topo 22,5x22,5**

| | | | | | | |
|---|---|---|--|---|---|---|
| <p> TACO CUADRI UNIKA TOPO 4 x 4 (G 01) 1,5" x 1,5" ♦ ⊗ 10 mm.</p> <p> TACO CUADRI UNIKA BARRO 4 x 4 (G 01) 1,5" x 1,5" ♦ ⊗ 10 mm.</p> <p> TACO CUADRI UNIKA SAGE 4 x 4 (G 01) 1,5" x 1,5" ♦ ⊗ 10 mm.</p> <p> TACO CUADRI UNIKA DENIM 4 x 4 (G 01) 1,5" x 1,5" ♦ ⊗ 10 mm.</p> | <p> TACO ROMBI UNIKA TOPO 4 x 4 (G 01) 1,5" x 1,5" ♦ ⊗ 10 mm.</p> <p> TACO ROMBI UNIKA BARRO 4 x 4 (G 01) 1,5" x 1,5" ♦ ⊗ 10 mm.</p> <p> TACO ROMBI UNIKA SAGE 4 x 4 (G 01) 1,5" x 1,5" ♦ ⊗ 10 mm.</p> <p> TACO ROMBI UNIKA DENIM 4 x 4 (G 01) 1,5" x 1,5" ♦ ⊗ 10 mm.</p> | <p> TACO UNIKA DENIM 4 x 4 (G 01) 1,5" x 1,5" ♦ ⊗ 10 mm.</p> <p> CROSS UNIKA DENIM 15,5 x 15,5 (G 81) 6" x 6" m² ⊗ 10 mm.</p> <p> STAR UNIKA DENIM 15,5 x 15,5 (G 81) 6" x 6" m² ⊗ 10 mm.</p> | <p> TACO UNIKA SAGE 4 x 4 (G 01) 1,5" x 1,5" ♦ ⊗ 10 mm.</p> <p> CROSS UNIKA SAGE 15,5 x 15,5 (G 81) 6" x 6" m² ⊗ 10 mm.</p> <p> STAR UNIKA SAGE 15,5 x 15,5 (G 81) 6" x 6" m² ⊗ 10 mm.</p> | <p> TACO UNIKA BARRO 4 x 4 (G 01) 1,5" x 1,5" ♦ ⊗ 10 mm.</p> <p> CROSS UNIKA BARRO 15,5 x 15,5 (G 81) 6" x 6" m² ⊗ 10 mm.</p> <p> STAR UNIKA BARRO 15,5 x 15,5 (G 81) 6" x 6" m² ⊗ 10 mm.</p> | <p> TACO UNIK TOPO 4 x 4 (G 01) 1,5" x 1,5" ♦ ⊗ 10 mm.</p> <p> CROSS UNIKA TOPO 15,5 x 15,5 (G 81) 6" x 6" m² ⊗ 10 mm.</p> <p> STAR UNIKA TOPO 15,5 x 15,5 (G 81) 6" x 6" m² ⊗ 10 mm.</p> | <p> TACO UNIK ARTICO 4 x 4 (G 01) 1,5" x 1,5" ♦ ⊗ 10 mm.</p> <p> CROSS UNIKA ARTICO 15,5 x 15,5 (G 81) 6" x 6" m² ⊗ 10 mm.</p> <p> STAR UNIKA ARTICO 15,5 x 15,5 (G 81) 6" x 6" m² ⊗ 10 mm.</p> |
|---|---|---|--|---|---|---|

IDEAS DE COLOCACIÓN · LAYOUT IDEAS

↻ Escala reducida · Reduced scale

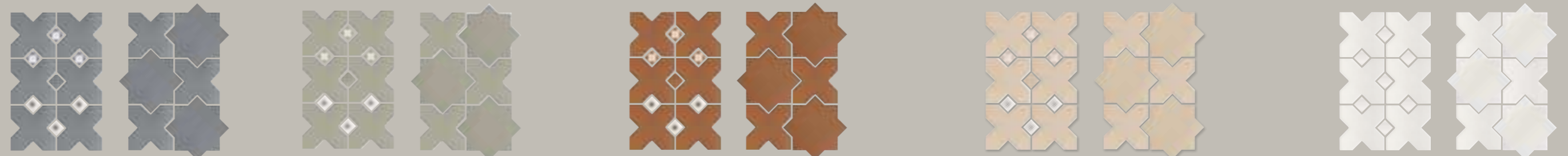



Pav. / Floor: **Unika Topo 22,5x45** - **Unika Boho 22,5x22,5**
Rev. / Wall: **Unika Topo 11x22,5**



Pav. / Floor: **Unika Trival 22,5x22,5**
Rev. / Wall: **Unika Sage 22,5x22,5** - **Unika Artico 11x22,5**



Rev. / Wall: **Unika Topo 11x22,5** - **Unika Denim 11x22,5**
Pav. / Floor: **Unika Revival 22,5x22,5**



Pav. / Floor: **Unika Midcentury 22,5x22,5**



IDEAS DE COLOCACIÓN
LAYOUT IDEAS

UNIKA BOHO 22,5 x 22,5 (G 86) 8,8" x 8,8" m²
Σ 10 mm.



UNIKA TRIVAL 22,5 x 22,5 (G 86) 8,8" x 8,8" m²
Σ 10 mm.



UNIKA REVIVAL 22,5 x 22,5 (G 86) 8,8" x 8,8" m²
Σ 10 mm.



IDEAS DE COLOCACIÓN
LAYOUT IDEAS

UNIKA MIDCENTURY 22,5 x 22,5 (G 86) 8,8" x 8,8" m²
Σ 10 mm.



IDEAS DE COLOCACIÓN
LAYOUT IDEAS

UNIKA ZEN 22,5 x 22,5 (G 86) 8,8" x 8,8" m²
Σ 10 mm.



UNIKA URBANO 22,5 x 22,5 (G 86) 8,8" x 8,8" m²
Σ 10 mm.



IDEAS DE COLOCACIÓN
LAYOUT IDEAS

UNIKA NEOLINE 22,5 x 22,5 (G 86) 8,8" x 8,8" m²
Σ 10 mm.



IDEAS DE COLOCACIÓN
LAYOUT IDEAS

UNIKA SFERA 22,5 x 22,5 (G 86) 8,8" x 8,8" m²
Σ 10 mm.

D'ANTICATTO

EXTRUSIONADO PORCELÁNICO
EXTRUDED PORCELAIN TILE

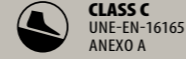
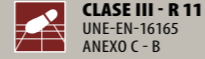

Pav. / Floor: D'Anticatto Muschio Antislip 22,5x22,5 - Peldaño Curvo D'Anticatto Muschio Antislip 22,5x33/4



Pav. / Floor: D'Anticatto Marrone Antislip 22,5x45 - D'Anticatto Marrone Antislip 11x22,5



Pav. / Floor: D'Anticatto Grigio Antislip 22,5x45 - D'Anticatto Grigio Antislip 22,5x22,5 - Peldaño Curvo D'Anticatto Grigio Antislip 22,5x33/4



D'ANTICATTO MUSCHIO ANTISLIP



D'ANTICATTO AZURRO ANTISLIP



D'ANTICATTO MARRONE ANTISLIP

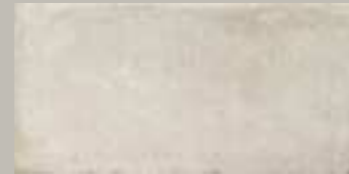

D'ANTICATTO BIANCO ANTISLIP



D'ANTICATTO GRIGIO ANTISLIP



D'ANTICATTO NOTTE ANTISLIP

ESPECIFICACIONES TÉCNICAS · TECHNICAL SPECIFICATIONS



RESISTE LA FLEXIÓN
29 N/mm²



RESISTE EL DESGASTE
PEI (II - IV)



RESISTE EL RAYADO
MOHS - 9



MANCHAS
Clase 5
Clase A



ABSORCIÓN
< 0,5%



DILATACIÓN
6,0° 10° / °C

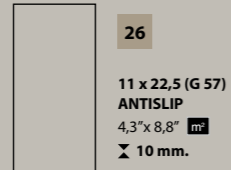
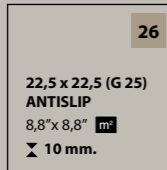
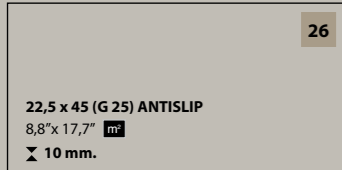

PIEZAS ESPECIALES · SPECIAL PIECES



PELDAÑO CURVO ANTISLIP
22,5 x 33/4 (G 16) 8,8" x 13"/1,5" ◆



ÁNG. PELDAÑO CURVO ANTISLIP
33 x 46/4 (G 19 x 2PZ) 13" x 18"/1,5" ◆



ÁNG. PELD. CURVO 4PZ. ANTISLIP
33 x 33/4 (G 58 x juego) 13" x 13"/1,5" ◆



ZÓCALO
9 x 30 (G 06) 3,5" x 11,8" ◆

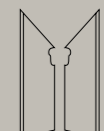

ZANQUÍN CV. · IZQ. / DRCH.
9 x 30 (G 10) 3,5" x 11,8" ◆

D'ANTICATTO

EXTRUSIONADO PORCELÁNICO
EXTRUDED PORCELAIN TILE

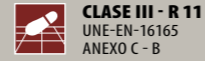

Pav. / Floor: **Obliqua Antislip 22,5x22,5**



Pav. / Floor: **Triangoli Antislip 22,5x22,5**



D'ANTICATTO OBLIQUA PERMITE
MÚLTIPLES POSIBILIDADES
COMPOSITIVAS

D'ANTICATTO OBLIQUA OFFERS
INFINITE LAYOUTS
POSSIBILITIES

D'ANTICATTO OBLIQUA PERMET
DE MULTIPLES POSSIBILITÉS
COMPOSITIVES

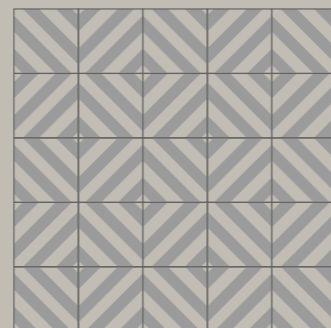
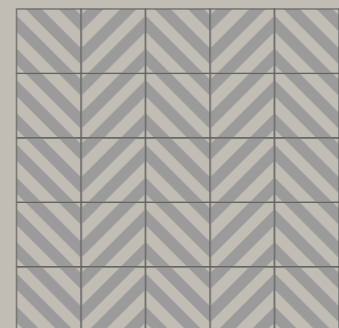
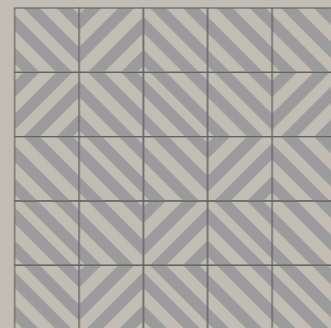

OBLIQUA ANTISLIP 22,5 x 22,5 (G 57) 8,8" x 8,8" m²
x 10 mm.

25



TRIANGOLI ANTISLIP 22,5 x 22,5 (G 57) 8,8" x 8,8" m²
x 10 mm.

25



QUADRATI ANTISLIP 22,5 x 22,5 (G 57) 8,8" x 8,8" m²
x 10 mm.

25

D'ANTICATTO

EXTRUSIONADO PORCELÁNICO
EXTRUDED PORCELAIN TILE

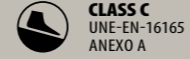
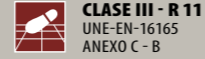

MIX VARESE ANTISLIP 22,5 x 22,5 (G 57) 8,8" x 8,8" ^{m²}
 ✂ 10 mm.

25

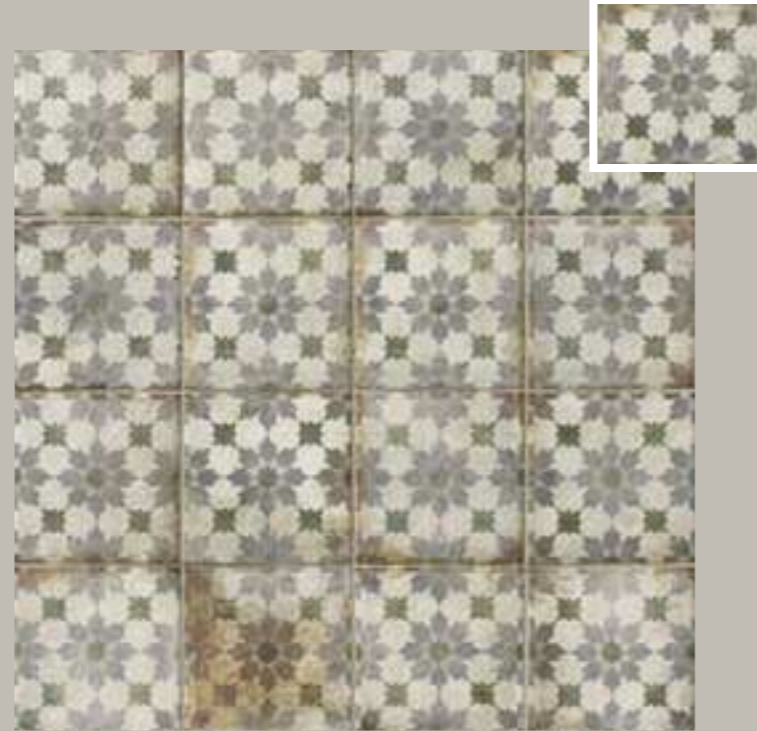

VARENNA ANTISLIP 22,5 x 22,5 (G 57) 8,8" x 8,8" ^{m²}
 ✂ 10 mm.

25



FLORENCE ANTISLIP 22,5 x 22,5 (G 57) 8,8" x 8,8" ^{m²}
 ✂ 10 mm.

25



LATERZA 2 ANTISLIP 2,5 x 22,5 (G 57) 8,8" x 8,8" ^{m²}
 ✂ 10 mm.

25



Pav. / Floor: Mix Varese Antislip 22,5x22,5

BOSTON

EXTRUSIONADO PORCELÁNICO
EXTRUDED PORCELAIN TILE

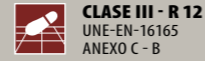

Rev. / Wall: Boston East Antislip 11x22,5



Rev. / Wall: Boston West Antislip 22,5x22,5 - Boston West Antislip 11x22,5



Pav. / Floor: Boston North Antislip 22,5x45



Pav. / Floor: Boston South Antislip 36x36 - Boston South Antislip 11x22,5
Vierteaguas Boston South Antislip 15x22,5/4



BOSTON DOWNTOWN ANTISLIP



BOSTON EAST ANTISLIP



BOSTON NORTH ANTISLIP

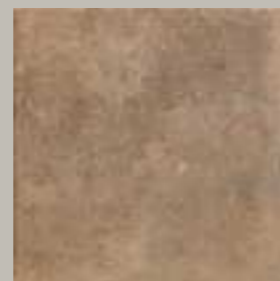

BOSTON SOUTH ANTISLIP



BOSTON WEST ANTISLIP

ESPECIFICACIONES TÉCNICAS - TECHNICAL SPECIFICATIONS



* Solo disponible en DOWNTOWN, EAST y NORTH
Only available in DOWNTOWN, EAST & NORTH

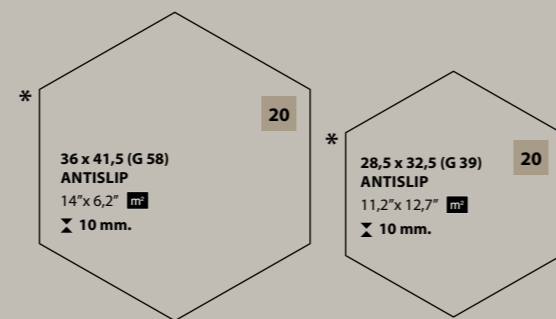
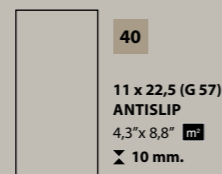
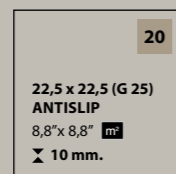
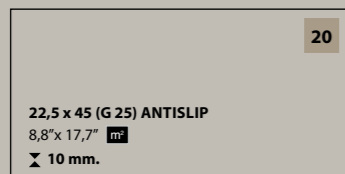
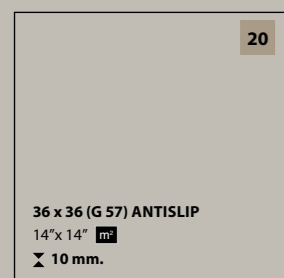

PIEZAS ESPECIALES - SPECIAL PIECES



PELDAÑO CURVO ANTISLIP
36 x 33/4 (G 18) 14" x 13"/1,5" ♦
22,5 x 33/4 (G 16) 8,8" x 13"/1,5" ♦



ÁNG. PELDAÑO CURVO ANTISLIP
33 x 46/4 (G 19 x 2PZ) 13" x 18"/1,5" ♦



VIERTEAGUAS ANTISLIP
15 x 22,5/4 (G 10) 5,9" x 8,8"/1,5" ♦

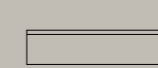

ZÓCALO
9 x 36 (G 07) 3,5" x 14" ♦

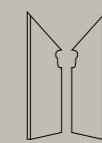

ZANQUÍN CV - IZQ. / DRCH.
9 x 36 (G 10) 3,5" x 14" ♦

AMERICAN

EXTRUSIONADO PORCELÁNICO
EXTRUDED PORCELAIN TILE

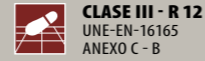

Pav. / Floor: American Melrose Antislip 22,5x22,5



Pav. / Floor: American Newton Antislip 22,5x22,5



AMERICAN MELROSE (MIX) ANTISLIP 22,5 x 22,5 (G 57) 8,8" x 8,8" m^2
x 10 mm.

20



AMERICAN NEWTON ANTISLIP 22,5 x 22,5 (G 57) 8,8" x 8,8" m^2
x 10 mm.

20



AMERICAN CLEVELAND ANTISLIP 22,5 x 22,5 (G 57) 8,8" x 8,8" m^2
x 10 mm.

20

BOSTON BRICK

EXTRUSIONADO PORCELÁNICO
EXTRUDED PORCELAIN TILE

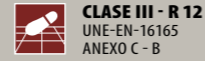

Pav. / Floor: Boston Brick East-North Antislip 6,5x25



Rev. / Wall: Boston Brick West Antislip 6,5x25



Rev. / Wall: Boston Brick Downtown Antislip 6,5x25
Pav. / Floor: Cottage Volcano 60x60



BOSTON BRICK DAY
* 6,5 x 25 - 2,5"x 10" - CLASE I - R9



BOSTON BRICK EAST - NORTH ANTISLIP



BOSTON BRICK DOWNTOWN ANTISLIP



BOSTON BRICK NIGHT
* 6,5 x 25 - 2,5"x 10" - CLASE I - R9



BOSTON BRICK SOUTH ANTISLIP



BOSTON BRICK WEST ANTISLIP



BRICK ANTISLIP
6,5 x 25 (G 39) 2,5"x 10"
± 10 mm.



BRICK DAY & NIGHT
6,5 x 25 (G 39) 2,5"x 10"
± 10 mm.



COTTO NATURE

EXTRUSIONADO PORCELÁNICO
EXTRUDED PORCELAIN TILE

CLASE III - R 11
UNE-EN-16165
ANEXO C - B



Pav. / Floor: Cotto Nature Sicilia Antislip 30x30 - Vierteaguas Cotto Nature Sicilia Antislip 15x30/4



Pav. / Floor: Cotto Nature Siena Antislip 36x36 - Peldaño Curvo Cotto Nature Siena Antislip 36x33/4 - Vierteaguas Cotto Nature Siena Antislip 15x30/4 - Zócalo Cotto Nature Siena 9x30 - Zanquín CV. Cotto Nature Siena 9x30



COTTO NATURE SICILIA ANTISLIP



COTTO NATURE SIENA ANTISLIP



COTTO NATURE CERDEÑA ANTISLIP

ESPECIFICACIONES TÉCNICAS - TECHNICAL SPECIFICATIONS



RESISTE LA FLEXIÓN
29 N/mm²



RESISTE EL DESGASTE
PEI (III - IV)



RESISTE EL RAYADO
MOHS - 8



MANCHAS
Clase 5
Clase A



ABSORCIÓN
0,2%



DILATACIÓN
5,7* 10⁻⁴ / °C

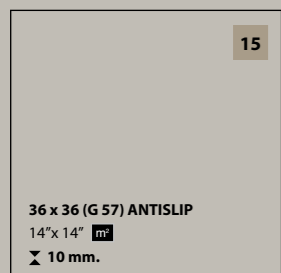

PIEZAS ESPECIALES - SPECIAL PIECES



PELDAÑO CURVO ANTISLIP
30 x 33/4 (G 17) 11,8" x 13"/1,5"
36 x 33/4 (G 18) 14" x 13"/1,5"



ÁNG. PELDAÑO CURVO ANTISLIP
33 x 46/4 (G 19 x 2PZ) 13" x 18"/1,5"



VIERTEAGUAS ANTISLIP
15 x 30/4 (G 12) 5,9" x 11,8"/1,5"

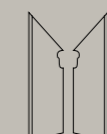

ZANQUÍN CV. - IZQ. / DCHA.
9 x 30 (G 10) 3,5" x 11,8"



ZÓCALO
9 x 30 (G 06) 3,5" x 11,8"

COTTO NATURE

EXTRUSIONADO PORCELÁNICO
EXTRUDED PORCELAIN TILE

CLASE I - R 9
UNE-EN-16165
ANEXO C - B



MATE
MATT



BRILLO
GLOSS



Pav. / Floor: Cotto Nature Sicilia Olio 36x36 - Losanga Cotto Nature Sicilia Olio 18x36 - Star Venice A, B y C 18x18 - Taco Venice 5x5



Pav. / Floor: Cotto Nature Cerdeña 36x36 - Cotto Nature Cerdeña 18x36 - Cotto Nature Cerdeña 18x18



COTTO NATURE SICILIA



COTTO NATURE SIENA



COTTO NATURE CERDEÑA

CLASE I - R 9

ESPECIFICACIONES TÉCNICAS - TECHNICAL SPECIFICATIONS



COTTO NATURE SICILIA OLIO



COTTO NATURE SIENA OLIO



COTTO NATURE CERDEÑA OLIO

CLASE I

ESPECIFICACIONES TÉCNICAS - TECHNICAL SPECIFICATIONS

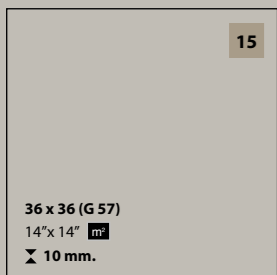

* NO disponible en CERDEÑA OLIO y SIENA OLIO
* NOT available in CERDEÑA OLIO & SIENA OLIO

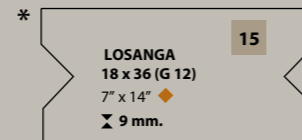
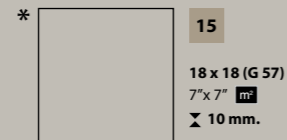
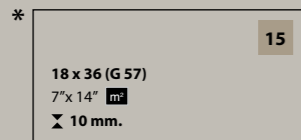

* LOSANGA NO disponible en CERDEÑA OLIO y SIENA OLIO
* LOSANGA NOT available in CERDEÑA OLIO & SIENA OLIO

PIEZAS ESPECIALES - SPECIAL PIECES

Solo disponible en acabado MATE - Only available in MATT finish



PELDAÑO CURVO
36 x 33/4 (G 18) 14" x 13 7/16"

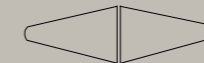

ÁNG. PELDAÑO CURVO
33 x 46/4 (G 19 x 2PZ)
13" x 18 1/16"



ZÓCALO
9 x 36 (G 607)
3,5" x 14"



ZANQUÍN CV. - IZQ. / DCHA.
9 x 36 (G 10)
3,5" x 14"

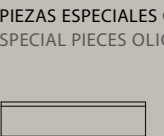

ZÓCALO
9 x 30 (G 06)
3,5" x 11,8"

PIEMONTE

EXTRUSIONADO PORCELÁNICO
EXTRUDED PORCELAIN TILE

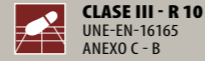

Pav. / Floor: Piemonte Torino Antislip 36x36 - Losanga Piemonte Torino Antislip 15,5x36 - Estrella Versilia A,B,C y D 15,5x15,5



Pav. / Floor: Piemonte Asti Antislip 36x36 - Losanga Piemonte Asti Antislip 15,5x36 - Star Piemonte Asti Antislip 15,5x15,5 - Taco Piemonte Asti Antislip 4x4
Rev. / Wall: Heritage Clay Ivory 120x120



PIEMONTE TORINO ANTISLIP



PIEMONTE NOVARA ANTISLIP



PIEMONTE ASTI ANTISLIP

ESPECIFICACIONES TÉCNICAS - TECHNICAL SPECIFICATIONS

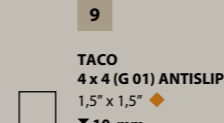
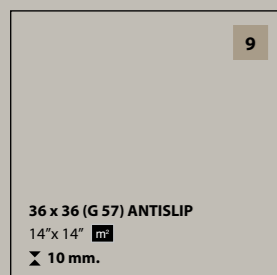

PIEZAS ESPECIALES - SPECIAL PIECES



PELDAÑO CURVO ANTISLIP
36 x 33/4 (G 18) 14" x 13 1/2"

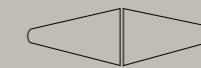

ÁNG. PELDAÑO CURVO ANTISLIP
33 x 46/4 (G 19 x 2PZ) 13" x 18 1/2"

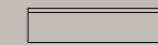

ZÓCALO
9 x 36 (G 07) 3,5" x 14"

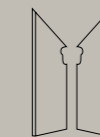

ZANQUÍN CV. - IZQ. / DCHA.
9 x 36 (G 10) 3,5" x 14"



ESTRELLA VERSILIA A
15,5 x 15,5 (G 31) 6" x 6"
18 x 18 (G 18) 7" x 7"



ESTRELLA VERSILIA B
15,5 x 15,5 (G 31) 6" x 6"
18 x 18 (G 18) 7" x 7"



ESTRELLA VERSILIA C
15,5 x 15,5 (G 31) 6" x 6"
18 x 18 (G 18) 7" x 7"

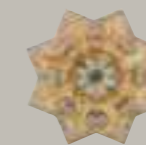

ESTRELLA VERSILIA D
15,5 x 15,5 (G 31) 6" x 6"
18 x 18 (G 18) 7" x 7"



FRONTAL VERSILIA
15,5 x 36 (G 21) 6" x 14"



TIRA VERSILIA
8 x 36 (G 18) 3" x 14"



TACO VERSILIA B
8 x 8 (G 12) 3" x 3"



TACO VERSILIA
8 x 8 (G 12) 3" x 3"



TACO VERSILIA
5 x 5 (G 04) 2" x 2"



TACO VERSILIA
4 x 4 (G 04) 1,5" x 1,5"

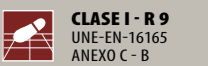

PIEMONTE

EXTRUSIONADO PORCELÁNICO
EXTRUDED PORCELAIN TILE

CLASE I - R 9
UNE-EN-16165
ANEXO C - B



Pav. / Floor: Piemonte Alessandria 36x36 - Piemonte Alessandria 18x36 - Piemonte Alessandria 18x18



Pav. / Floor: Piemonte Biella 36x36



PIEMONTE ALESSANDRIA



PIEMONTE BIELLA



PIEMONTE VERCELLI

ESPECIFICACIONES TÉCNICAS - TECHNICAL SPECIFICATIONS



RESISTE LA FLEXIÓN
29 N/mm²



RESISTE EL DESGASTE
PEI (II - IV)



RESISTE EL RAYADO
MOHS-5



MANCHAS
Clase 5
Clase A



ABSORCIÓN
0,2%



DILATACIÓN
5,7* 10⁻⁴ /°C

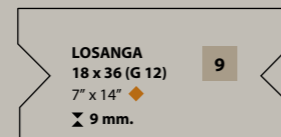
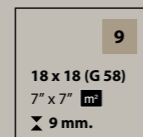
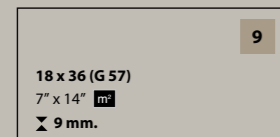
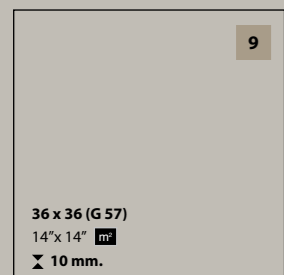

ESTRELLA VERSILIA A
15,5 x 15,5 (G 31) 6" x 6"
18 x 18 (G 18) 7" x 7"



ESTRELLA VERSILIA B
15,5 x 15,5 (G 31) 6" x 6"
18 x 18 (G 18) 7" x 7"



ESTRELLA VERSILIA C
15,5 x 15,5 (G 31) 6" x 6"
18 x 18 (G 18) 7" x 7"

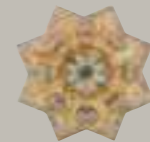

ESTRELLA VERSILIA D
15,5 x 15,5 (G 31) 6" x 6"
18 x 18 (G 18) 7" x 7"



FRONTAL VERSILIA
15,5 x 36 (G 21) 6" x 14"



TIRA VERSILIA
8 x 36 (G 18) 3" x 14"



TACO VERSILIA B
8 x 8 (G 12) 3" x 3"



TACO VERSILIA
8 x 8 (G 12) 3" x 3"



TACO VERSILIA
5 x 5 (G 04) 2" x 2"



TACO VERSILIA
4 x 4 (G 04) 1,5" x 1,5"

TECH-LAND

EXTRUSIONADO PORCELÁNICO
EXTRUDED PORCELAIN TILE

CLASE III - R 11
UNE-EN-16165
ANEXO C - B

CLASS C
UNE-EN-16165
ANEXO A

14 mm
ESPESOR
THICKNESS



Pav. / Floor: **Tech Land Fire Antislip 11x22,5** - Peldaño Curvo Tech Land Fire Antislip 30x33/4
Rev. / Wall: **Boston Brick Downtown 6,5x25**



Pav. / Floor: **Tech Land Natural Antislip 22,5x22,5** - Peldaño Curvo Tech Land Natural Antislip 30x33/4 - Borde Piscina Tech Land Natural Antislip 28x66,5/4 - Esquina Interior Borde Piscina Tech Land Natural Antislip 28x66,5x43/4



TECH LAND FIRE
ANTISLIP



TECH LAND NATURAL
ANTISLIP

ESPECIFICACIONES TÉCNICAS - TECHNICAL SPECIFICATIONS

| | | | | | | | |
|---|--|--------------------------------------|--------------------------------------|--------------------------|------------------------------------|------------------------------------|-----------------------------------|
| | | | | | | | |
| RESISTE LA FLEXIÓN 89 N/mn ² | RESISTE EL DESGASTE PEI (II - III) | RESISTE EL RAYADO MOHS - 8 | MANCHAS Clase 5 Clase A | ABSORCIÓN 0,3% | DILATACIÓN 6,6° 10° / °C | FUERZA DE ROTURA 3119 Nw | CARGA DE ROTURA 3408 Nw |

22,5 x 22,5 (G 58)
ANTISLIP
8,8" x 8,8"
14 mm.

30 x 30 (G 38)
ANTISLIP
11,8" x 11,8"
14 mm.

22,5 x 33 (G 58)
ANTISLIP
8,8" x 13"
14 mm.

11 x 22,5 (G 58)
ANTISLIP
4,3" x 8,8"
14 mm.

* Solo disponible en FIRE
Only available in FIRE

PIEZAS ESPECIALES - SPECIAL PIECES



PELDAÑO CURVO ANTISLIP
30 x 33/4 (G 17) 11,8" x 13"/1,5" ◆



ÁNG. PELDAÑO CURVO ANTISLIP
33 x 46/4 (G 19 x 2PZ) 13" x 18"/1,5" ◆



ÁNG. PELD. CURVO ANTISLIP 4PZ.
33 x 33/4 (G 78 x juego) 13" x 13"/1,5" ◆



VIERTEAGUAS ANTISLIP
15 x 30/4 (G 12) 5,9" x 11,8"/1,5" ◆

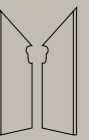

ZANQUÍN CV. - IZQ. / DCHA.
9 x 30 (G 10) 3,5" x 11,8" ◆

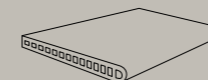

BORDE PISCINA ANTISLIP
28 x 66,5/4 (G 80) 10" x 26,5"/1,5" ◆

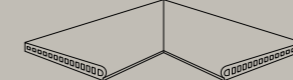

ESQUINA INT. BORDE PISCINA ANTISLIP
28 x 66,5 x 43/4 (G 56 x 2PZ)
10" x 26,5" x 17"/1,5" ◆



ESQUINA EXT. BORDE PISCINA ANTISLIP
28 x 66,5 x 43/4 (G 56 x 2PZ)
10" x 26,5" x 17"/1,5" ◆

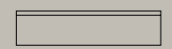

ZÓCALO
9 x 30 (G 06) 3,5" x 11,8" ◆

TECH-LAND

EXTRUSIONADO PORCELÁNICO
EXTRUDED PORCELAIN TILE

CLASE III - R 11
UNE-EN-16165
ANEXO C - B

CLASS C
UNE-EN-16165
ANEXO A

14 mm
ESPESOR
THICKNESS



Pav. / Floor: Tech Land Temple Fire Antislip 22,5x22,5
Tech Land Fire Antislip 22,5x33 · Tech Land Fire Antislip 11x22,5



Pav. / Floor: Tech Land Coat Fire Antislip 22,5x22,5 · Tech Land Fire Antislip 22,5x22,5



Pav. / Floor: Tech Land Temple Natural Antislip 22,5x22,5



TECH LAND TEMPLE FIRE ANTISLIP 22,5 x 22,5 (G 56) 8,8" x 8,8"
14 mm.

17



TECH LAND COAT FIRE ANTISLIP 22,5 x 22,5 (G 56) 8,8" x 8,8"
14 mm.

17



TECH LAND TEMPLE NATURAL ANTISLIP 22,5 x 22,5 (G 56) 8,8" x 8,8"
14 mm.

17

TECH-LAND

EXTRUSIONADO PORCELÁNICO
EXTRUDED PORCELAIN TILE

CLASE III - R 11
UNE-EN-16165
ANEXO C - B

CLASS C
UNE-EN-16165
ANEXO A

14 mm
ESPESOR
THICKNESS



Pav. / Floor: Tech Land Star Temple Fire Antislip 15,5x15,5 - Tech Land Cross Fire Antislip 15,5x15,5



Pav. / Floor: Tech Land Star Fire Antislip 15,5x15,5 - Tech Land Cross Fire Antislip 15,5x15,5



TECH LAND STAR FIRE ANTISLIP
15,5 x 15,5 (G 52) 6" x 6" m
14 mm.



TECH LAND STAR TEMPLE FIRE ANTISLIP
15,5 x 15,5 (G 52) 6" x 6" m
14 mm.



TECH LAND CROSS FIRE ANTISLIP
15,5 x 15,5 (G 52) 6" x 6" m
14 mm.



TECH LAND CROSS TEMPLE FIRE ANTISLIP
15,5 x 15,5 (G 52) 6" x 6" m
14 mm.



TECH LAND CROSS FIRE ANTISLIP
TECH LAND STAR TEMPLE FIRE ANTISLIP



TECH LAND CROSS TEMPLE FIRE ANTISLIP
TECH LAND STAR TEMPLE FIRE ANTISLIP



TECH LAND CROSS FIRE ANTISLIP
TECH LAND STAR FIRE ANTISLIP

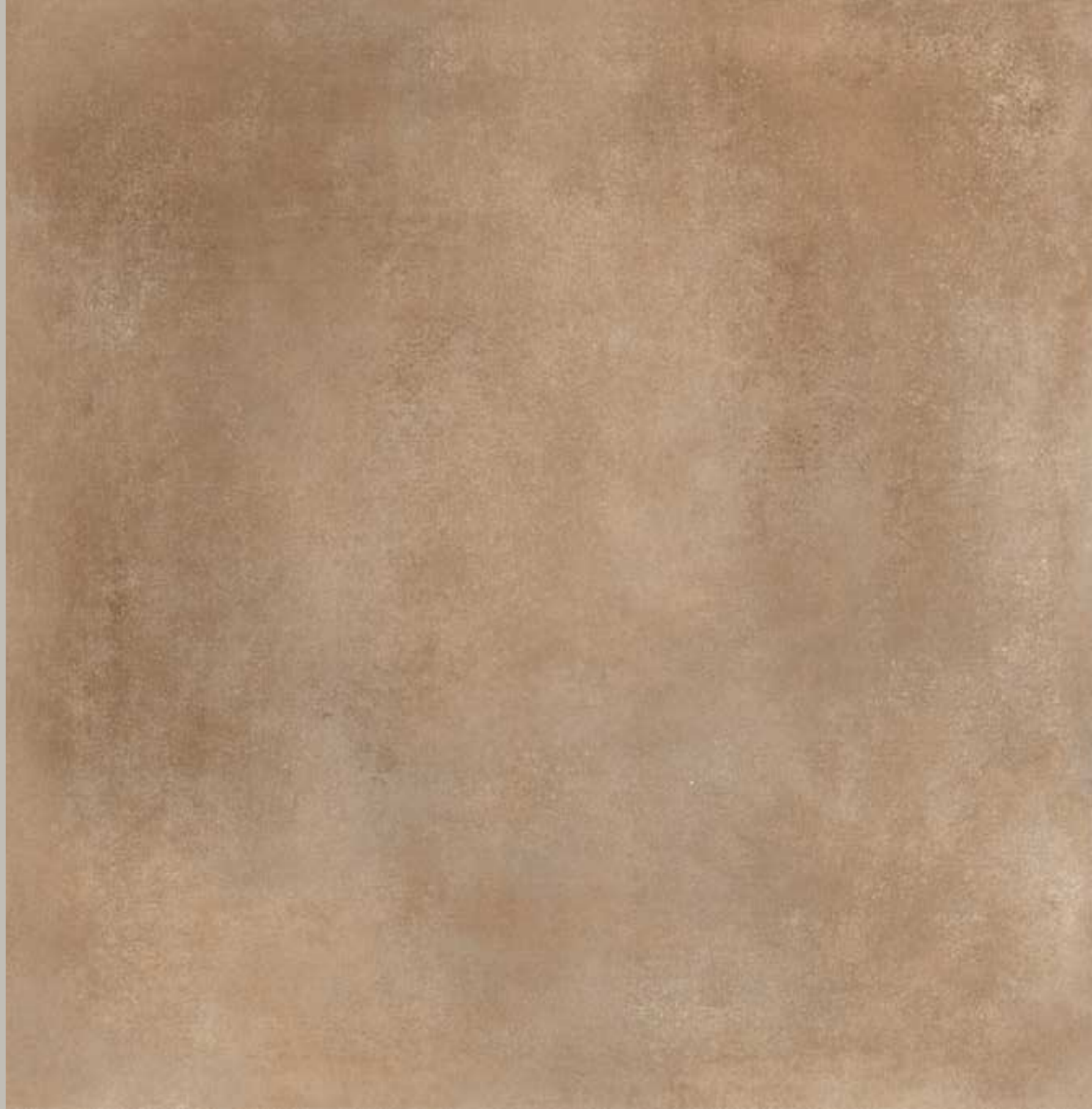

Heritage Clay Cotto 120x120 · Heritage Clay Cotto 60x120 · Heritage Clay Cotto 60x60

HERITAGE CLAY, la esencia de la piedra llevada al lenguaje cerámico.
HERITAGE CLAY, the essence of stone translated into ceramic language.

HERITAGE CLAY



NATUCER
cerámica natural

NEW
2026

 **matera**
BEYOND THE SURFACE

HERITAGE CLAY

Matera es la nueva tecnología de Natucer que eleva el porcelánico mediante la combinación de diseño y precisión tecnológica, creando superficies con carácter propio. Su propuesta **multiformato** y acabados premium ofrece a diseñadores y arquitectos nuevas posibilidades para desarrollar espacios con identidad y sofisticación.

Destaca por su calidad, durabilidad e innovación, consolidándose como un referente en el diseño cerámico. Además, su gama de **piezas especiales** garantizan **continuidad visual** y acabados envolventes en suelos, revestimientos, coronaciones e incluso piscinas.

Matera is Natucer's new technology that elevates porcelain stoneware by combining design and technological precision, creating surfaces with distinctive character. Its multi-format approach and premium finishes offer designers and architects new possibilities to develop spaces with identity and sophistication.

It stands out for its quality, durability, and innovation, establishing itself as a benchmark in ceramic design. In addition, its range of special pieces ensures visual continuity and seamless finishes in floors, wall coverings, coping, and even swimming pools.

NATUCER
cerámica natural



Pav. / Floor: **Heritage Clay Cotto 120x120**
Rev. / Wall: **Heritage Clay Cotto 120x120**

NEW
2026

HERITAGE CLAY

HERITAGE CLAY es una nueva serie inspirada en la piedra natural, disponible en 7 colores diferentes. Su diseño destaca por la modularidad de sus piezas y la continuidad de textura y volumen entre todas ellas, logrando una armonía visual fluida y coherente en cualquier espacio.

HERITAGE CLAY is a new stone-inspired ceramic series available in 7 different colors. Its design stands out for the modularity of its pieces and the continuity of texture and volume across all formats, creating a smooth and cohesive visual harmony in any space.



HERITAGE CLAY

PORCELÁNICO RECTIFICADO
RECTIFIED PORCELAIN TILE

NEW
2026

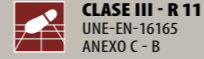

HERITAGE CLAY WHITE
HERITAGE CLAY WHITE
ANTISLIP

HERITAGE CLAY IVORY
HERITAGE CLAY IVORY
ANTISLIP

HERITAGE CLAY PEARL
HERITAGE CLAY PEARL
ANTISLIP

HERITAGE CLAY GREIGE
HERITAGE CLAY GREIGE
ANTISLIP

HERITAGE CLAY COTTO
HERITAGE CLAY COTTO
ANTISLIP

HERITAGE CLAY BLUE

HERITAGE CLAY EMERALD

Colores BLUE y EMERALD solo disponibles en CLASE I - R9
BLUE & EMERALD colors only available in CLASS I - R9

120 x 120 (G 80)
120 x 120 (G 80) ANTISLIP
48" x 48" m^2
± 8 mm.

9

60 x 120 (G 86)
60 x 120 (G 79) ANTISLIP
24" x 48" m^2
± 8 mm.

30 x 30 (5x5) (G 16)
12" x 12" (2" x 2") m^2
± 8 mm.

9

15 x 15 (G 68)
6" x 6" m^2
± 8 mm.

9

6,5 x 20 (G 68)
2,5" x 8" m^2
± 8 mm.

9

60 x 60 (G 73)
60 x 60 (G 86) ANTISLIP
24" x 24" m^2
± 8 mm.

9

30 x 60 (G 73)
30 x 60 (G 86) ANTISLIP
12" x 24" m^2
± 8 mm.

9



Pav. / Floor: Heritage Clay Blue 120x120
Rev. / Wall: Heritage Clay White 120x120 - Heritage Clay Blue 6,5x20



Pav. / Floor: Heritage Clay White 120x120 - Sherwood Linde 20x120 - Peldaño Recto Sherwood Linde 120x33/3
Rev. / Wall: Lineage White 6,5x20

HERITAGE CLAY

PORCELÁNICO RECTIFICADO
RECTIFIED PORCELAIN TILE

NEW
2026



EXTRUSIONADO PORCELÁNICO
EXTRUDED PORCELAIN TILE



PIEZAS ESPECIALES · SPECIAL PIECES

Disponible en WHITE, IVORY, PEARL, GREIGE y COTTO - Available in WHITE, IVORY, PEARL, GREIGE & COTTO

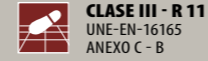

CLASE III - R 11
UNE-EN-16165
ANEXO C - B

PELDAÑO BLOCK

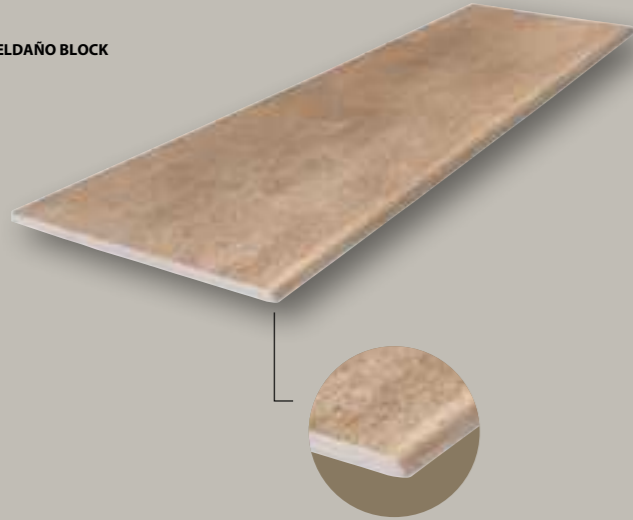

BORDE PISCINA

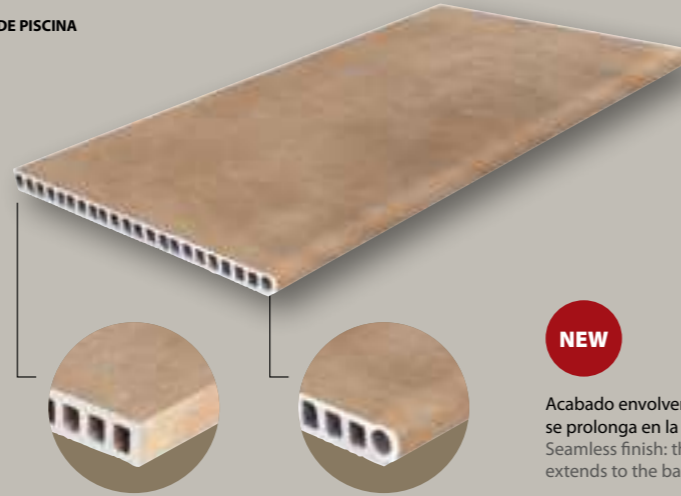

NEW

Acabado envolvente: el diseño se prolonga en la parte trasera.
Seamless finish: the design extends to the back.

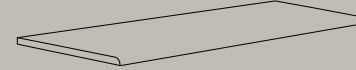

PELDAÑO BLOCK ANTISLIP
120 x 33/1,4 (G 79) 48" x 13"/0,5"



BORDE PISCINA ANTISLIP
45 x 120/3 (G 83) 17,7" x 48"/1"
45 x 60/3 (G 80) 17,7" x 23,6"/1"

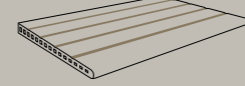

DESBORDANTE ANTISLIP
30,5 x 50/2,4 (G 80)
11,8" x 20"/1"

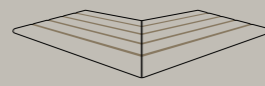

ESQ. EXT. DESBORDANTE ANTISLIP
30,5 x 50 x 40/2,4 (G 56 x 2PZ)
11,8" x 20" x 16"/1"

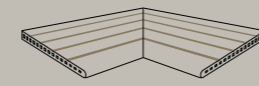

ESQ. INT. DESBORDANTE ANTISLIP
30,5 x 50 x 40/2,4 (G 56 x 2PZ)
11,8" x 20" x 16"/1"

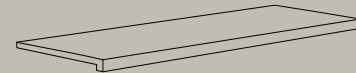

PELDAÑO RECTO ANTISLIP
120 x 32/3 (G 72) 48" x 12,5"/1"
60 x 32/3 (G 73) 23,6" x 12,5"/1"



GRATTING ANTISLIP
25 x 50/2,2 (G 78)
10" x 20"/1"

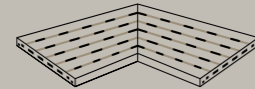

ÁNG. GRATTING ANTISLIP
25 x 50 x 35/2,2 (G 60 x 2PZ)
10" x 20" x 15"/1"



SISTEMA GRATTING SIN IMPACTO
NON IMPACT GRATTING SYSTEM
SYSTÈME DE GRATTEGE SANS IMPACT



GOMA PARA GRATTING / GRATTING RUBBER
22,5 x 1,7 · 8,8" x 0,4"
(SE NECESITAN 2 ud. POR GRATTING)

ÁNG. PELDAÑO RECTO EXT. / INT. ANTISLIP
120 x 32 x 45/3 (G 46 x 2PZ)
48" x 12,5" x 17,7"/1"

EXTRUSIONADO PORCELÁNICO
EXTRUDED PORCELAIN TILE



PIEZAS ESPECIALES · SPECIAL PIECES

Disponible en WHITE, BLUE y EMERALD - Available in WHITE, BLUE & EMERALD



CUBRECANTO
4 x 30 x 4 (G 15) 1,5" x 11,8" x 1,5"



COMP. EXT. CUBRECANTO
4 x 4 (G 17) 1,5" x 1,5"



COMP. INT. CUBRECANTO
4 x 4 (G 17) 1,5" x 1,5"

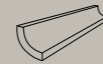

MEDIA CAÑA INT.
4 x 30 x 4 (G 13) 1,5" x 11,8" x 1,5"



COMP. INT. MEDIA CAÑA
4 x 4 (G 17) 1,5" x 1,5"



COMP. EXT. MEDIA CAÑA
4 x 4 (G 17) 1,5" x 1,5"

EXTRUSIONADO PORCELÁNICO
EXTRUDED PORCELAIN TILE



PIEZAS ESPECIALES · SPECIAL PIECES

Disponible en todos los colores - Available in all colors



CLASE I - R 9
UNE-EN-16165
ANEXO C - B



PELDAÑO RECTO
120 x 32/3 (G 72) 48" x 12,5"/1"
60 x 32/3 (G 73) 23,6" x 12,5"/1"

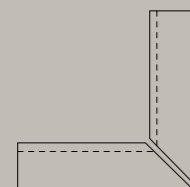

ÁNG. PELDAÑO RECTO INT.
120 x 32 x 45/3 (G 46 x 2PZ)
48" x 12,5" x 17,7"/1"

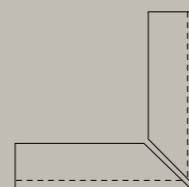

ÁNG. PELDAÑO RECTO EXT.
120 x 32 x 45/3 (G 46 x 2PZ)
48" x 12,5" x 17,7"/1"



FRONTAL
15 x 120 (G 74) 6" x 48"



ZÓCALO
9,8 x 120 (G 74) 4" x 48"
9,8 x 60 (G 75) 4" x 23,6"



Pav. / Floor: Heritage Clay Cotto 120x120 · Peldaño Recto Heritage Clay Cotto 120x32/3 · Frontal Heritage Clay Cotto 15x120

HERITAGE CLAY 20mm

PORCELÁNICO RECTIFICADO
RECTIFIED PORCELAIN TILE

NEW
2026

matera
BETWEEN THE SURFACES

CLASE III - R 11
UNE-EN-16165
ANEXO C - B

20 mm
ESPESOR
THICKNESS



BORDES RECTIFICADOS - Rectified Edges



HERITAGE CLAY WHITE ANTISLIP
60 x 120 x 2 (G 76) 24" x 48" x 1" **mm**
20 mm.

9



HERITAGE CLAY IVORY ANTISLIP
60 x 120 x 2 (G 76) 24" x 48" x 1" **mm**
20 mm.

9



HERITAGE CLAY GREIGE ANTISLIP
60 x 120 x 2 (G 76) 24" x 48" x 1" **mm**
20 mm.

9

BORDES IRREGULARES - Irregular Edges



HERITAGE CLAY WHITE ANTISLIP
60 x 90 x 2 (G 79) 24" x 36" x 1" **mm**
20 mm.

9



HERITAGE CLAY IVORY ANTISLIP
60 x 90 x 2 (G 79) 24" x 36" x 1" **mm**
20 mm.

9



HERITAGE CLAY GREIGE ANTISLIP
60 x 90 x 2 (G 79) 24" x 36" x 1" **mm**
20 mm.

9



Colocación mínima recomendada de PLOTS para los formatos
60x120 Rec. y 60x90 con espesor de 20mm.
Placement of the minimum recommended PLOTS 60x120 Rec.
and 60x90 with a thickness of 20 mm.



Esquema de montaje con baldosas
Mounting scheme with tiles

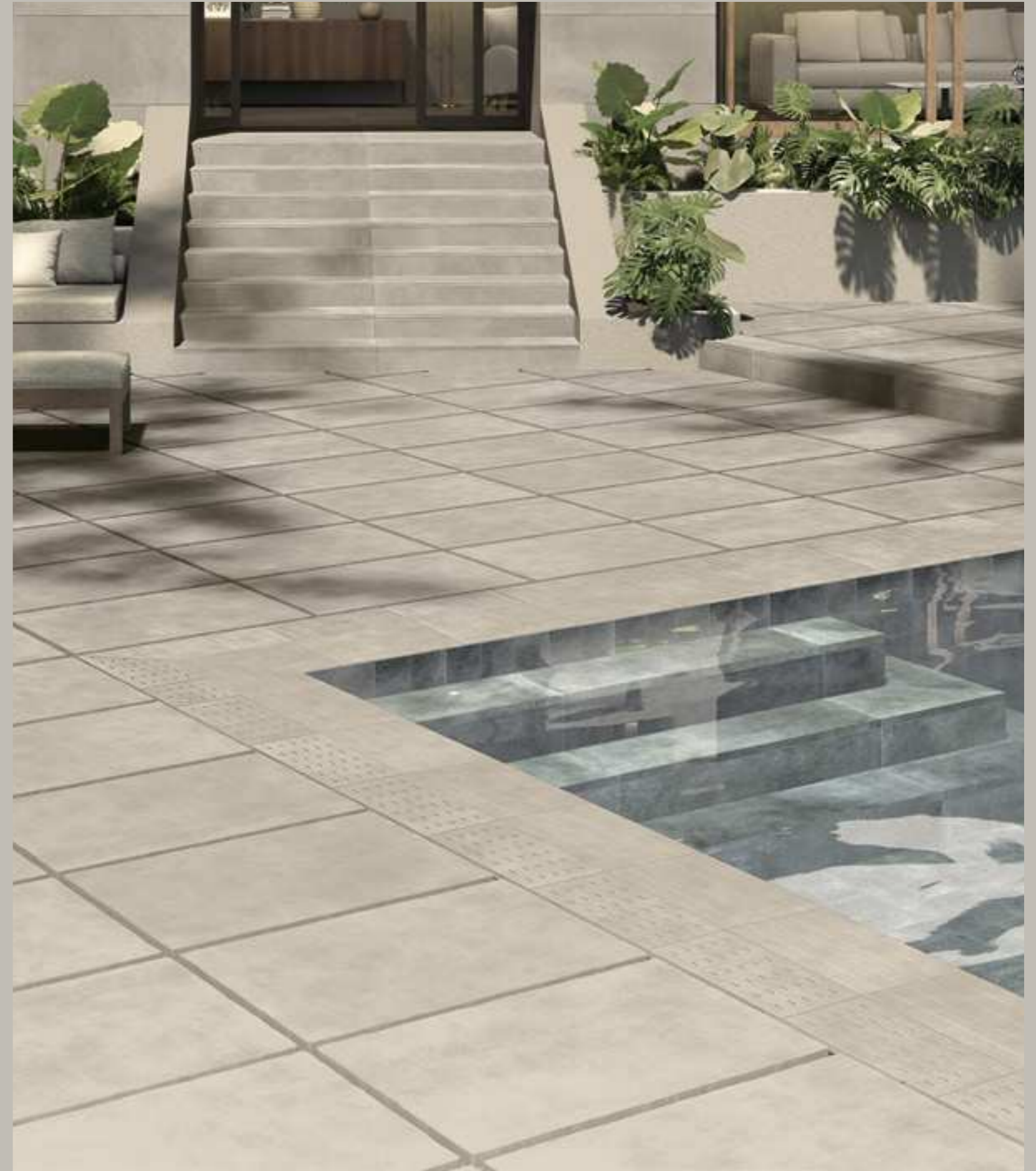
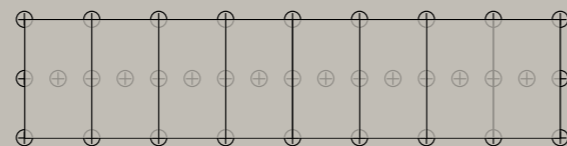

Pav. / Floor: Heritage Clay Greige Antislip 60x90x2 · Peldaño Recto Heritage Clay Greige Antislip 120x32/3 · Frontal Heritage Clay Greige 15x120 · Grating Heritage Clay Greige Antislip 25x50/2,2
Ángulo Grating Heritage Clay Greige Antislip 25x50x35/2,2 · Desbordante Heritage Clay Greige Antislip 30,5x50/2,4 · Esq. Int. Desbordante Heritage Clay Greige Antislip 30,5x50x40/2,4
Vaso Piscina / Pool Basin: Heritage Clay Emerald 15x15 · Peldaño Recto Heritage Clay Emerald 120x32/3 · Frontal Heritage Clay Emerald 15x120
Rev. / Wall: Heritage Clay Greige 60x120

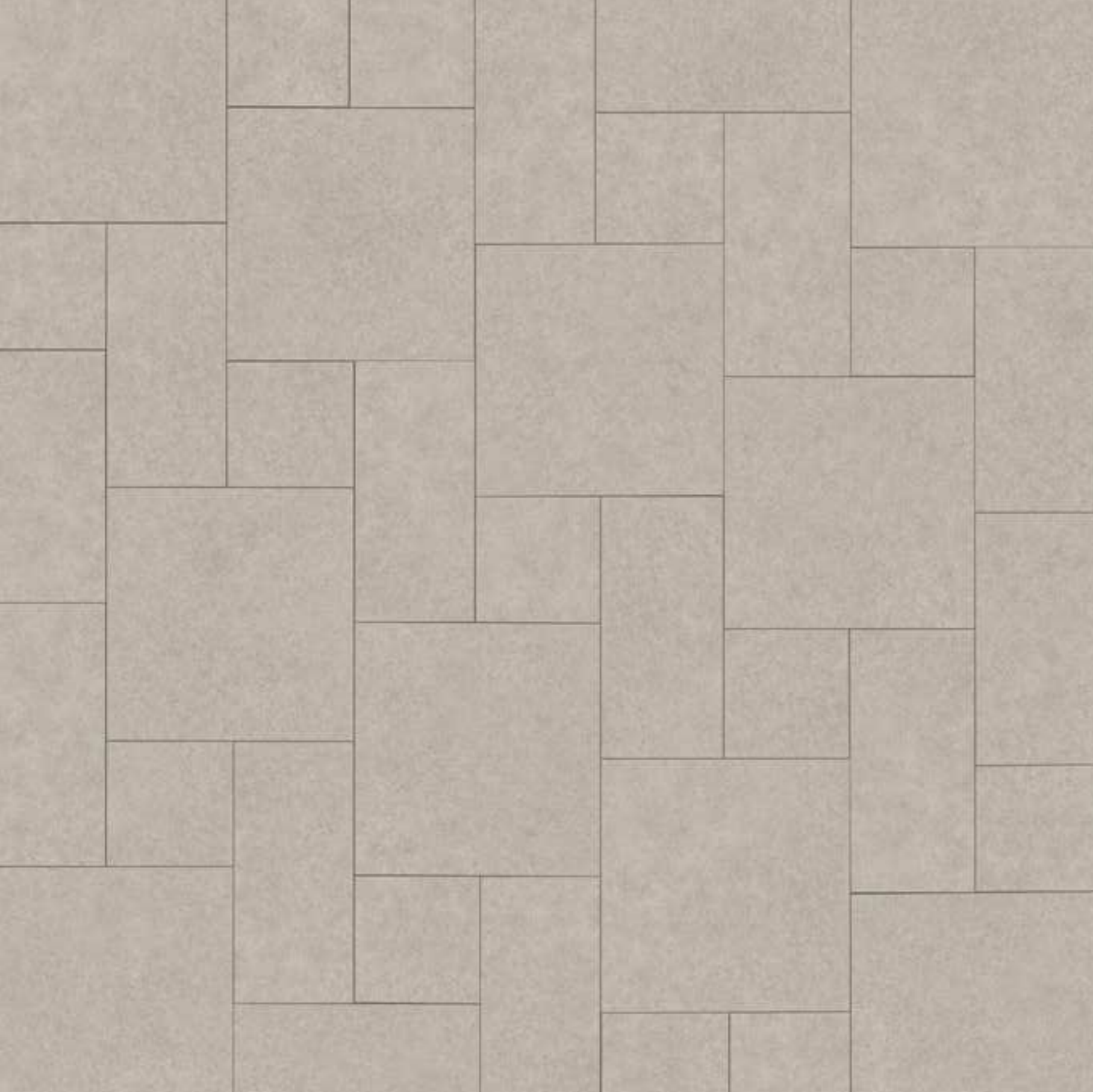

Sarsen Stone Greige 120x120 - Sarsen Stone Greige 60x120 - Sarsen Stone Greige 60x60



SARSEN STONE, la calma de la piedra en diseño actual.
SARSEN STONE, the calmness of stone in contemporary design.

SARSEN STONE



NATUCER
cerámica natural

NEW
2026

matera
BEYOND THE SURFACE

SARSEN STONE

Matera es la nueva tecnología de Natucer que eleva el porcelánico mediante la combinación de diseño y precisión tecnológica, creando superficies con carácter propio. Su propuesta **multiformato** y acabados premium ofrece a diseñadores y arquitectos nuevas posibilidades para desarrollar espacios con identidad y sofisticación.

Destaca por su calidad, durabilidad e innovación, consolidándose como un referente en el diseño cerámico. Además, su gama de piezas especiales garantizan **continuidad visual** y acabados envolventes en suelos, revestimientos, coronaciones e incluso piscinas.

Matera is Natucer's new technology that elevates porcelain stoneware by combining design and technological precision, creating surfaces with distinctive character. Its multi-format approach and premium finishes offer designers and architects new possibilities to develop spaces with identity and sophistication.

It stands out for its quality, durability, and innovation, establishing itself as a benchmark in ceramic design. In addition, its range of special pieces ensures visual continuity and seamless finishes in floors, wall coverings, coping, and even swimming pools.

NATUCER
cerámica natural



Pav. / Floor: Sarsen Stone Greige 120x120 - Sarsen Stone Greige 60x120 - Sarsen Stone Greige 60x60
Rev. / Wall: Sarsen Stone Greige 60x120 - Sarsen Stone White 15x15

NEW
2026

SARSEN STONE

SARSEN STONE es una serie inspirada en la piedra, con una cuidada paleta de colores neutros. Su diseño transmite equilibrio y naturalidad, dando lugar a superficies serenas y atemporales que se integran con elegancia en cualquier espacio, tanto interior como exterior.

SARSEN STONE is a series inspired by stone, featuring a carefully chosen neutral color palette. Its design conveys balance and naturalness, creating serene and timeless surfaces that integrate elegantly into any space, both indoors and outdoors.



SARSEN STONE

PORCELÁNICO RECTIFICADO
RECTIFIED PORCELAIN TILE

NEW
2026

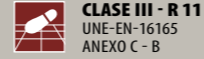

SARSEN STONE WHITE
SARSEN STONE WHITE ANTISLIP
* 15 x 15 - 6" x 6" - CLASE I - R9
* 5 x 25 - 2" x 10" - CLASE I - R9

SARSEN STONE IVORY
SARSEN STONE IVORY ANTISLIP

SARSEN STONE GREIGE
SARSEN STONE GREIGE ANTISLIP

CLASE I - R9
160 x 160 (G 55)
64" x 64"
⊗ 8 mm.

CLASE I - R 9
UNE-EN-16165
ANEXO C - B

6

120 x 120 (G 80)
120 x 120 (G 80) ANTISLIP
48" x 48"
⊗ 8 mm.

6

60 x 120 (G 86)
60 x 120 (G 79) ANTISLIP
24" x 48"
⊗ 8 mm.

6

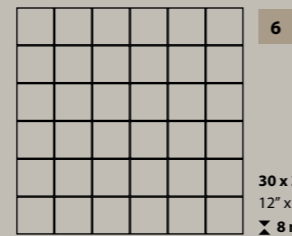

30 x 30 (G 73)
30 x 30 (G 86) ANTISLIP
12" x 24"
⊗ 8 mm.

6

60 x 60 (G 73)
60 x 60 (G 86) ANTISLIP
24" x 24"
⊗ 8 mm.

6



Pav. / Floor: Sarsen Stone Greige Antislip 120x120 - Borde Piscina Antislip 45x120/3 - Peldaño Block Antislip 120x33/1,4 - Sarsen Stone Greige Antislip 60x120x2
Vaso Piscina / Pool Basin: Sarsen Stone Turquoise Bali 15x15



* 6
15 x 15 (G 68)
6" x 6"
⊗ 8 mm.



SARSEN STONE
WHITE



SARSEN STONE
TURQUOISE BALI

* 15x15 solo disponible en WHITE y TURQUOISE BALI
* 6"x6" only available in WHITE & TURQUOISE BALI

* 6
5 x 25 (G 68) 2" x 10"
⊗ 8 mm.

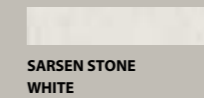

SARSEN STONE
WHITE

* 5x25 solo disponible en WHITE
* 2"x10" only available in WHITE

SARSEN STONE

PORCELÁNICO RECTIFICADO
RECTIFIED PORCELAIN TILE

NEW
2026



EXTRUSIONADO PORCELÁNICO
EXTRUDED PORCELAIN TILE



PIEZAS ESPECIALES - SPECIAL PIECES
Disponible en WHITE, IVORY y GREIGE - Available in WHITE, IVORY & GREIGE

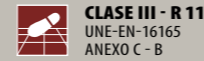

CLASE III - R 11
UNE-EN-16165
ANEXO C - B

PELDAÑO BLOCK

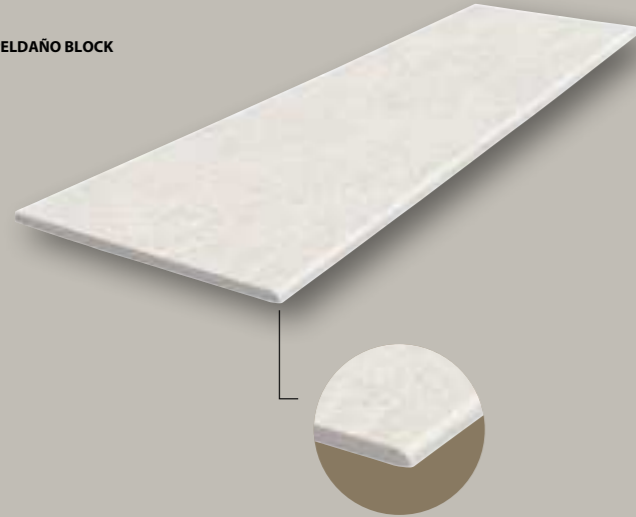

BORDE PISCINA

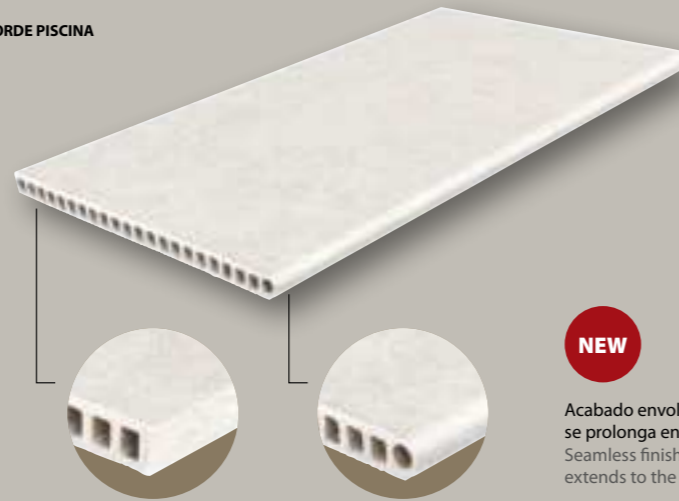

NEW

Acabado envolvente: el diseño se prolonga en la parte trasera.
Seamless finish: the design extends to the back.

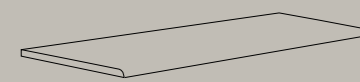

PELDAÑO BLOCK ANTISLIP
120 x 33/1,4 (G 79) 48" x 13"/0,5"



BORDE PISCINA ANTISLIP
45 x 120/3 (G 83) 17,7" x 48"/1"
45 x 60/3 (G 80) 17,7" x 23,6"/1"

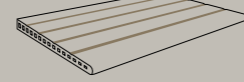

DESBORDANTE ANTISLIP
30,5 x 50/2,4 (G 80)
11,8" x 20"/1"

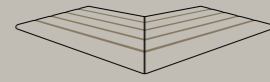

ESQ. EXT. DESBORDANTE ANTISLIP
30,5 x 50 x 40/2,4 (G 56 x 2PZ)
11,8" x 20" x 16"/1"

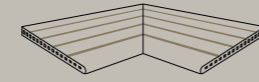

ESQ. INT. DESBORDANTE ANTISLIP
30,5 x 50 x 40/2,4 (G 56 x 2PZ)
11,8" x 20" x 16"/1"

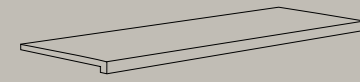

PELDAÑO RECTO ANTISLIP
120 x 32/3 (G 72) 48" x 12,5"/1"
60 x 32/3 (G 73) 23,6" x 12,5"/1"

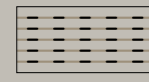

GRATTING ANTISLIP
25 x 50/2,2 (G 78)
10" x 20"/1"

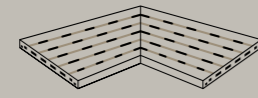

ÁNG. GRATTING ANTISLIP
25 x 50 x 35/2,2 (G 60 x 2PZ)
10" x 20" x 15"/1"

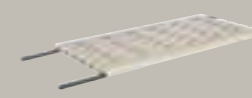

SISTEMA GRATTING SIN IMPACTO
NON IMPACT GRATTING SYSTEM
SYSTÈME DE GRATTING SANS IMPACT



GOMA PARA GRATTING / GRATTING RUBBER
22,5 x 1,7 - 8,8" x 0,4"
(SE NECESITAN 2 ud. POR GRATTING)

ÁNG. PELDAÑO RECTO EXT. / INT. ANTISLIP
120 x 32 x 45/3 (G 46 x 2PZ)
48" x 12,5" x 17,7"/1"

EXTRUSIONADO PORCELÁNICO
EXTRUDED PORCELAIN TILE



PIEZAS ESPECIALES - SPECIAL PIECES
Disponible en WHITE, IVORY y TURQUOISE BALI - Available in WHITE & IVORY



CUBRECANTO
4 x 30 x 4 (G 15) 1,5" x 11,8" x 1,5"



COMP. EXT. CUBRECANTO
4 x 4 (G 17) 1,5" x 1,5"



COMP. INT. CUBRECANTO
4 x 4 (G 17) 1,5" x 1,5"

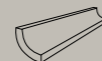

MEDIA CAÑA INT.
4 x 30 x 4 (G 13) 1,5" x 11,8" x 1,5"



COMP. INT. MEDIA CAÑA
4 x 4 (G 17) 1,5" x 1,5"



COMP. EXT. MEDIA CAÑA
4 x 4 (G 17) 1,5" x 1,5"

EXTRUSIONADO PORCELÁNICO
EXTRUDED PORCELAIN TILE



PIEZAS ESPECIALES - SPECIAL PIECES
Disponible en WHITE, IVORY y GREIGE - Available in WHITE, IVORY & GREIGE



CLASE I - R 9
UNE-EN-16165
ANEXO C - B



PELDAÑO RECTO
120 x 32/3 (G 72) 48" x 12,5"/1"
60 x 32/3 (G 73) 23,6" x 12,5"/1"

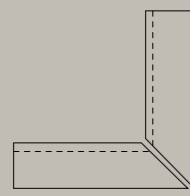

ÁNG. PELDAÑO RECTO INT.
120 x 32 x 45/3 (G 46 x 2PZ)
48" x 12,5" x 17,7"/1"

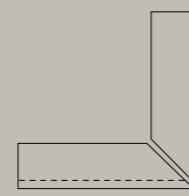

ÁNG. PELDAÑO RECTO EXT.
120 x 32 x 45/3 (G 46 x 2PZ)
48" x 12,5" x 17,7"/1"



FRONTAL
15 x 120 (G 74) 6" x 48"

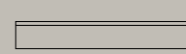

ZÓCALO
9,8 x 120 (G 74) 4" x 48"
9,8 x 60 (G 75) 4" x 23,6"

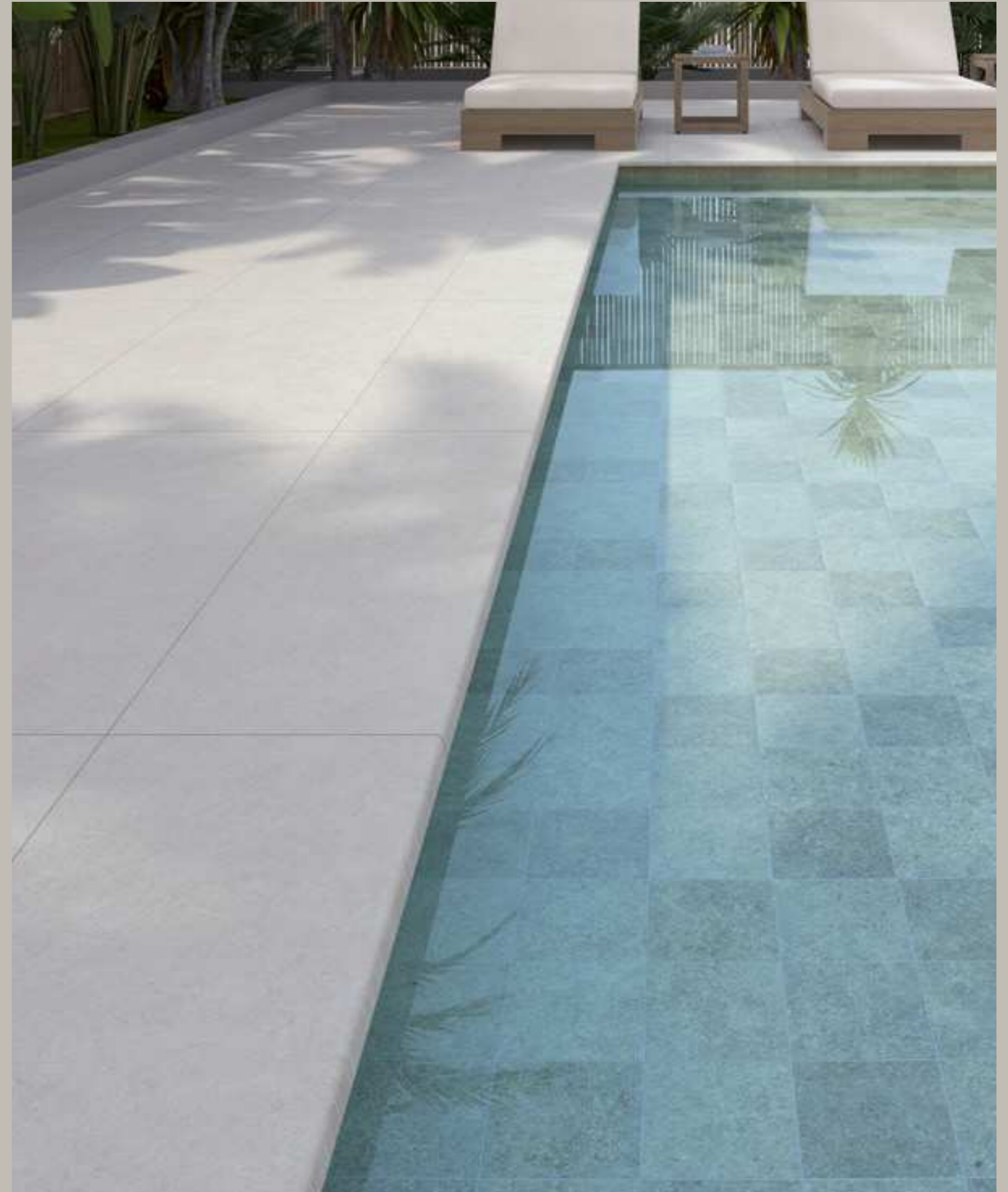

Pav. / Floor: Sarsen Stone White Antislip 60x120 - Peldaño Recto Sarsen Stone White Antislip 120x32/3 - Ángulo Peldaño Recto Int. Sarsen Stone White Antislip 120x32x45/3
Vaso Piscina / Pool Basin: Sarsen Stone Turquoise Bali 15x15

SARSEN STONE 20mm

PORCELÁNICO RECTIFICADO
RECTIFIED PORCELAIN TILE

NEW
2026

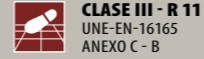

BORDES RECTIFICADOS - Rectified Edges

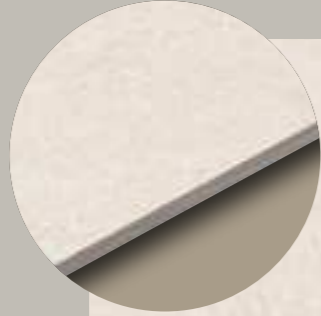
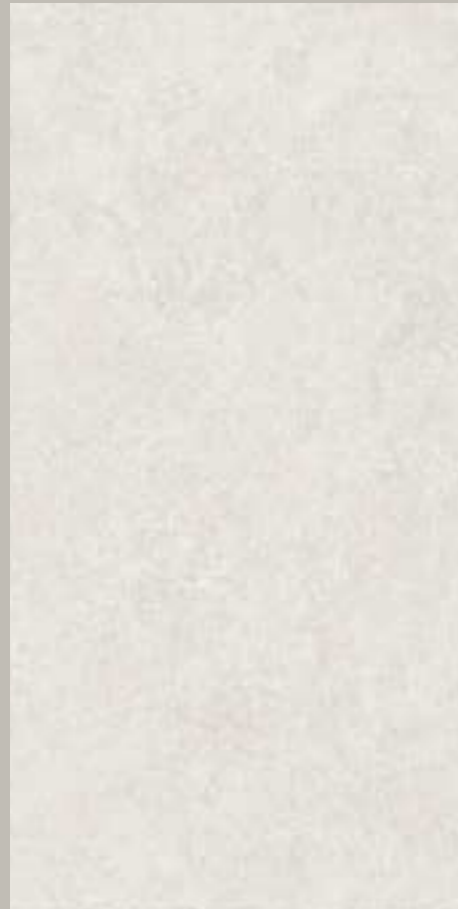

SARSEN STONE WHITE ANTISLIP
60 x 120 x 2 (G 76) 24" x 48" x 1" **m²**
20 mm.



SARSEN STONE IVORY ANTISLIP
60 x 120 x 2 (G 76) 24" x 48" x 1" **m²**
20 mm.

BORDES IRREGULARES - Irregular Edges

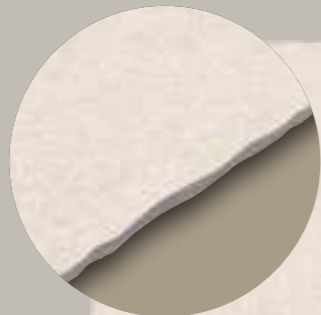
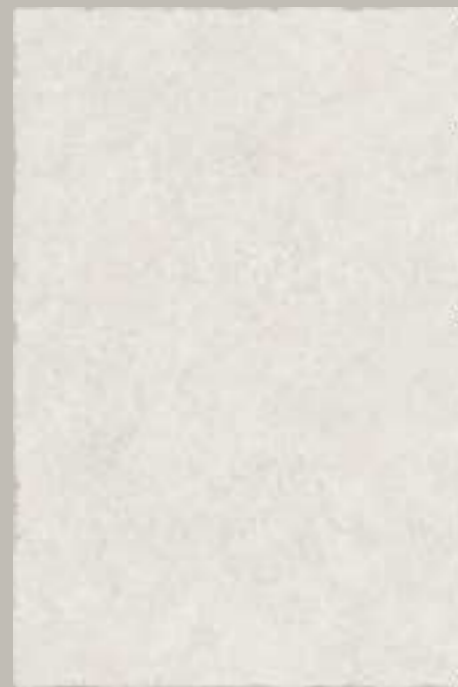

SARSEN STONE WHITE ANTISLIP
60 x 90 x 2 (G 79) 24" x 36" x 1" **m²**
20 mm.



SARSEN STONE IVORY ANTISLIP
60 x 90 x 2 (G 79) 24" x 36" x 1" **m²**
20 mm.



Pav. / Floor: Sarsen Stone Ivory Antislip 60x90 · Peldaño Recto Sarsen Stone Ivory Antislip 120x32/3 · Ángulo Peldaño Recto Int. / Ext. Sarsen Stone Ivory Antislip 120x32x45/3 · Frontal Sarsen Stone Ivory Antislip 15x120
Vaso Piscina / Pool Basin: Sarsen Stone Turquoise Bali 15x15



Colocación mínima recomendada de PLOTS para los formatos 60x120 Rec. y 60x90 con espesor de 20mm.
Placement of the minimum recommended PLOTS 60x120 Rec. and 60x90 with a thickness of 20 mm.



Esquema de montaje con baldosas
Mounting scheme with tiles

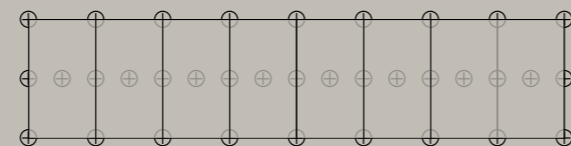

ORION

PORCELÁNICO RECTIFICADO
RECTIFIED PORCELAIN TILE

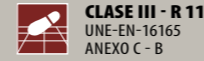

Pav. / Floor: **Orion White Antislip 90x90** · Peldaño Recto Orion White Antislip 120x33/3
Rev. / Wall: **Orion White 90x90**



Pav. / Floor: **Orion Greige 90x90** · Peldaño Recto Orion Greige 120x33/3
Rev. / Wall: **Orion Greige 90x90**



Pav. / Floor: **Orion Graphite 90x90**
Rev. / Wall: **Orion Graphite 90x90**

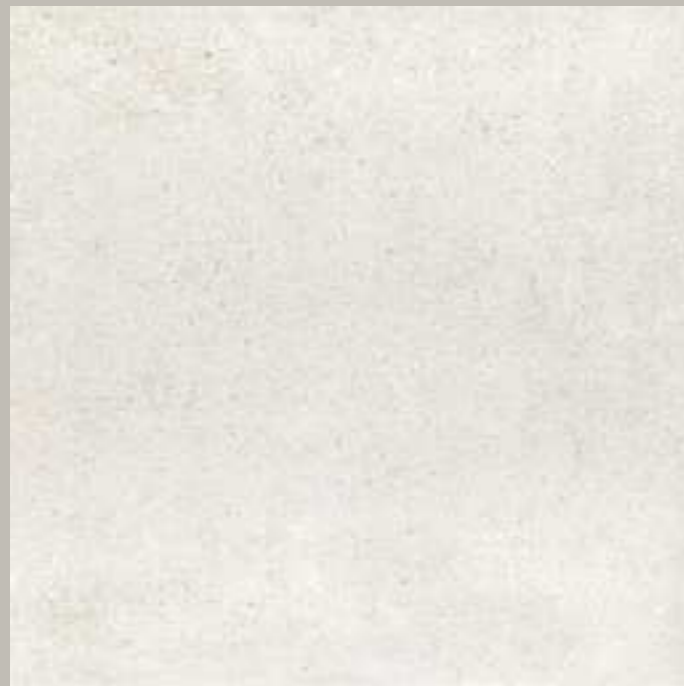

ORION WHITE 90 x 90 (G 79) 35,4" x 35,4" ^{m²}
ORION WHITE 90 x 90 (G 80) ANTISLIP 35,4" x 35,4" ^{m²}
± 9 mm.

10



ORION GREIGE 90 x 90 (G 79) 35,4" x 35,4" ^{m²}
ORION GREIGE 90 x 90 (G 80) ANTISLIP 35,4" x 35,4" ^{m²}
± 9 mm.

10

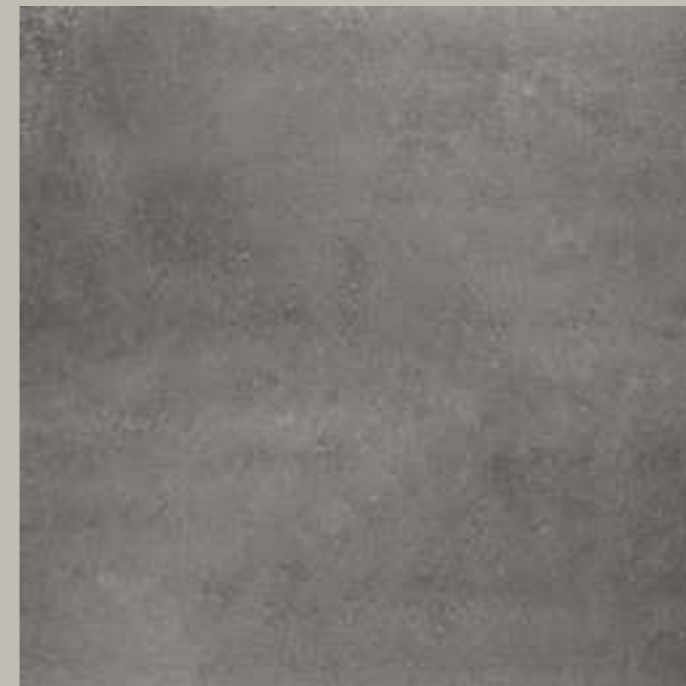

ORION GRAPHITE 90 x 90 (G 79) 35,4" x 35,4" ^{m²}
± 9 mm.

10

PIEZAS ESPECIALES · SPECIAL PIECES
Disponible en todos los colores · Available in all colors

SPECIAL ORDER
BAJO PEDIDO

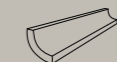

MEDIA CAÑA INT.
4 x 30 x 4 (G 13)
1,5" x 11,8" x 1,5"



COMP. INT. MEDIA CAÑA
4 x 4 (G 17)
1,5" x 1,5"



COMP. EXT. MEDIA CAÑA
4 x 4 (G 17)
1,5" x 1,5"



CUBRECANTO
4 x 30 x 4 (G 15)
1,5" x 11,8" x 1,5"



COMP. INT. CUBRECANTO
4 x 4 (G 17)
1,5" x 1,5"



COMP. EXT. CUBRECANTO
4 x 4 (G 17)
1,5" x 1,5"

EXTRUSIONADO PORCELÁNICO
EXTRUDED PORCELAIN TILE



PIEZAS ESPECIALES · SPECIAL PIECES
Disponible en WHITE y GREIGE · Available in WHITE & GREIGE

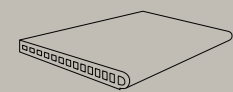

BORDE PISCINA ANTISLIP
28 x 66,5/4 (G 80)
10" x 26,5" x 1,5"

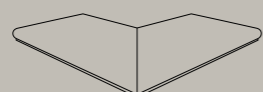

ESQUINA EXT. BORDE PISCINA ANTISLIP
28 x 66,5 x 43/4 (G 56 x 2PZ)
10" x 26,5" x 17" x 1,5"

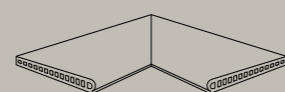

ESQUINA INT. BORDE PISCINA ANTISLIP
28 x 66,5 x 43/4 (G 56 x 2PZ)
10" x 26,5" x 17" x 1,5"

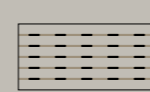

GRATTING ANTISLIP
25 x 50/2,2 (G 78)
10" x 20" x 1"

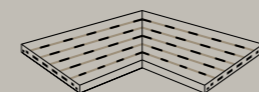

ÁNGULO GRATTING ANTISLIP
25 x 50 x 35/2,2 (G 60 x 2PZ)
10" x 20" x 15" x 1"

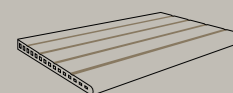

DESBORDANTE ANTISLIP
30,5 x 50/2,4 (G 80)
11,8" x 20" x 1"

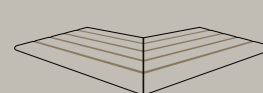

ESQ. EXT. DESBORDANTE ANTISLIP
30,5 x 50 x 40/2,4 (G 56 x 2PZ)
11,8" x 20" x 16" x 1"

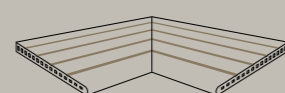

ESQ. INT. DESBORDANTE ANTISLIP
30,5 x 50 x 40/2,4 (G 56 x 2PZ)
11,8" x 20" x 16" x 1"



GOMA PARA GRATTING
GRATTING RUBBER
22,5 x 1,7 8,8" x 0,4"
(SE NECESITAN 2 ud.
POR GRATTING)



SISTEMA GRATTING SIN IMPACTO
NON IMPACT GRATTING SYSTEM
SYSTÈME DE GRATTEGE SANS IMPACT

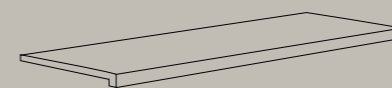
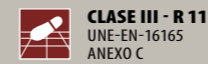

PELDAÑO RECTO ANTISLIP
120 x 33/3 (G 72) 48" x 13" x 1"
60 x 33/3 (G 73) 23,6" x 13" x 1"

ÁNG. PELDAÑO RECTO INT. / EXT. ANTISLIP
120 x 33 x 45/3 (G 46 x 2)
48" x 13" x 17,7" x 1"

EXTRUSIONADO PORCELÁNICO
EXTRUDED PORCELAIN TILE



PIEZAS ESPECIALES · SPECIAL PIECES
Disponible en todos los colores · Available in all colors

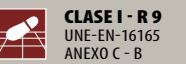

PELDAÑO RECTO
120 x 33/3 (G 72) 48" x 13" x 1"
60 x 33/3 (G 73) 23,6" x 13" x 1"

ÁNG. PELDAÑO RECTO INT. / EXT.
120 x 33 x 45/3 (G 46 x 2)
48" x 13" x 17,7" x 1"



ÁNG. PELDAÑO RECTO
33 x 45/3 (G 18 x 2PZ)
13" x 17,7" x 1"

REMATE PELDAÑO RECTO - IZQ. / DRCH.
3 x 33 (G 15) 1" x 13"

ZÓCALO
8,5 x 90 (G 31)
3,5" x 35,4"

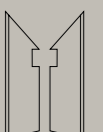

ZANQUÍN RCT. IZQ. / DRCH.
8,5 x 30 (G 13)
3,5" x 11,8"



Pav. / Floor: **Alma Crema 90x90 - Alma Crema Antislip 90x90**
Rev. / Wall: **Alma Crema 90x90**



Pav. / Floor: **Alma Marfil Antislip 90x90 - Peldaño Recto Alma Marfil Antislip 120x33/3 - Ángulo Peldaño Recto Int. Alma Marfil Antislip 120x33x45/3**
Rev. / Wall: **Alma Marfil 90x90**



ALMA CREMA 90 x 90 (G 79) 35,4" x 35,4" **m²**
ALMA CREMA 90 x 90 (G 80) ANTISLIP 35,4" x 35,4" **m²**
⊗ 9,5 mm.

6

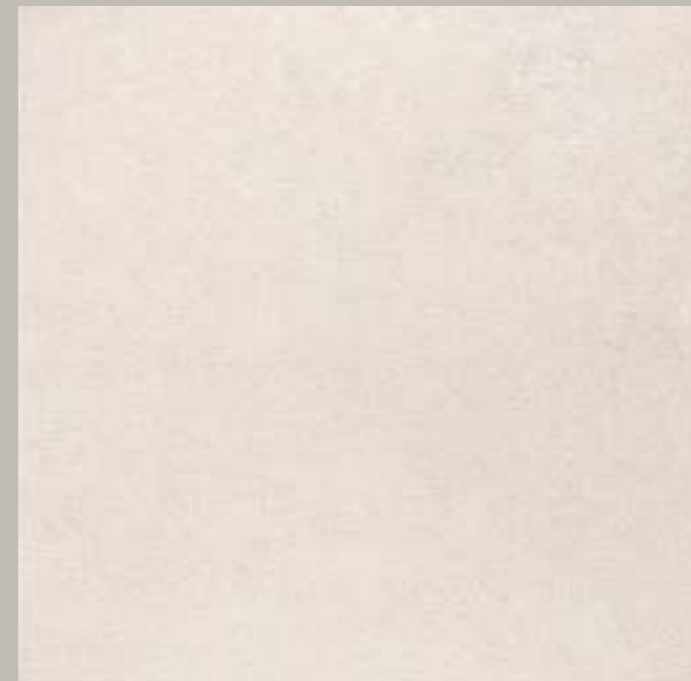

ALMA MARFIL 90 x 90 (G 79) 35,4" x 35,4" **m²**
ALMA MARFIL 90 x 90 (G 80) ANTISLIP 35,4" x 35,4" **m²**
⊗ 9,5 mm.

6

EXTRUSIONADO PORCELÁNICO · PIEZAS ESPECIALES · SPECIAL PIECES
EXTRUDED PORCELAIN TILE



PELDAÑO RECTO
PELDAÑO RECTO ANTISLIP
120 x 33/3 (G 72) 48" x 13"/1" ♦
60 x 33/3 (G 73) 23,6" x 13"/1" ♦

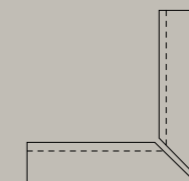

ÁNG. PELDAÑO RECTO INT.
ÁNG. PELDAÑO RECTO INT. ANTISLIP
120 x 33 x 45/3 (G 46 x 2)
48" x 13" x 17,7"/1" ♦

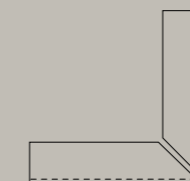

ÁNG. PELDAÑO RECTO EXT.
ÁNG. PELDAÑO RECTO EXT. ANTISLIP
120 x 33 x 45/3 (G 46 x 2)
48" x 13" x 17,7"/1" ♦



ÁNG. PELDAÑO RECTO
33 x 45/3 (G 18 x 2PZ)
13" x 17,7"/1" ♦

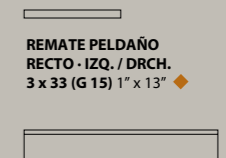

REMATE PELDAÑO
RECTO - IZQ. / DRCH.
3 x 33 (G 15) 1" x 13" ♦

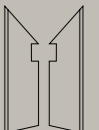

ZANQUÍN REC.
IZQ. / DRCH.
8,5 x 30 (G 13)
3,5" x 11,8" ♦



Pav. / Floor Anima Ceniza 90x90 · Peldaño Angular Anima Ceniza 120x32/3



Pav. / Floor: Anima Arena 90x90 · Peldaño Angular Anima Arena 120x32/3
Remate Peldaño Ang. Anima Arena 3x32 · Zócalo Anima Arena 8,5x90 · Zanquín Ang. Anima Arena 8,5x30



Pav. / Floor Anima Luna Antislip 90x90 · Peldaño Angular Anima Luna Antislip 120x32/3 · Ángulo Peldaño Angular Int. Anima Luna Antislip 120x32x45/3 · Zanquín Angular Anima Luna 8,5x30



ANIMA CENIZA 90 x 90 (G 79) 35,4" x 35,4" **m²**
ANIMA CENIZA 90 x 90 (G 80) ANTISLIP 35,4" x 35,4" **m²**
x 9 mm.

12



ANIMA ARENA 90 x 90 (G 79) 35,4" x 35,4" **m²**
ANIMA ARENA 90 x 90 (G 80) ANTISLIP 35,4" x 35,4" **m²**
x 9 mm.





12



ANIMA LUNA 90 x 90 (G 79) 35,4" x 35,4" **m²**
ANIMA LUNA 90 x 90 (G 80) ANTISLIP 35,4" x 35,4" **m²**
x 9 mm.

12

ESPECIFICACIONES TÉCNICAS CLASE I - R9 · TECHNICAL SPECIFICATIONS CLASE I - R9

| | | | | | |
|--|---|---|---|--|--|
|  RESISTE LA FLEXIÓN 51 N/mm ² |  RESISTE EL DESGASTE PEI (III - IV) |  RESISTE EL RAYADO MOHS - 5 |  MANCHAS Clase 5 Clase A |  ABSORCIÓN 0,1 % |  CARGA DE ROTURA 3059 Nw |
|--|---|---|---|--|--|

ESPECIFICACIONES TÉCNICAS CLASE III - R11 · TECHNICAL SPECIFICATIONS CLASE III - R11

| | | | | | |
|--|---|---|---|--|--|
|  RESISTE LA FLEXIÓN 51 N/mm ² |  RESISTE EL DESGASTE PEI (III - IV) |  RESISTE EL RAYADO MOHS - 6-9 |  MANCHAS Clase 5 Clase A |  ABSORCIÓN 0,1 % |  CARGA DE ROTURA 3059 Nw |
|--|---|---|---|--|--|



EXTRUSIONADO PORCELÁNICO · PIEZAS ESPECIALES · SPECIAL PIECES
EXTRUDED PORCELAIN TILE



PELDAÑO ANGULAR
PELDAÑO ANGULAR ANTISLIP
120 x 32/3 (G 72) 48" x 12,5"/1" ♦
60 x 32/3 (G 73) 23,6" x 12,5"/1" ♦

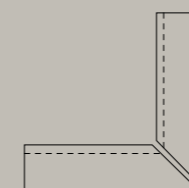

ÁNG. PELDAÑO ANG. INT.
ÁNG. PELDAÑO ANG. INT. ANTISLIP
120 x 32 x 45/3 (G 46 x 2) 48" x 12,5" x 17,7"/1" ♦

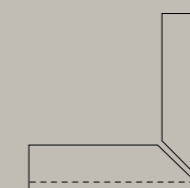

ÁNG. PELDAÑO ANG. EXT.
ÁNG. PELDAÑO ANG. EXT. ANTISLIP
120 x 32 x 45/3 (G 46 x 2) 48" x 12,5" x 17,7"/1" ♦

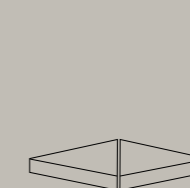

ÁNG. PELDAÑO ANG.
32 x 45/3 (G 18 x 2PZ) 12,5" x 17,7"/1" ♦

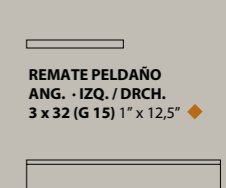

ZÓCALO
8,5 x 90 (G 31) 3,5" x 35,4" ♦



ZANQUÍN ANG.
IZQ. / DRCH. 8,5 x 30 (G 13) 3,5" x 11,8" ♦



Pav. / Floor: Anima Ceniza Antislip 22,5x22,5 - Peldaño Angular Anima Ceniza Antislip 120x32/3



Pav. / Floor: Decor Anima Ceniza Antislip 22,5x22,5



Pav. / Floor: Anima Arena Antislip 22,5x22,5 - Decor Anima Arena Antislip 22,5x22,5 - Peldaño Angular Anima Arena Antislip 120x32/3



DECOR LINEAL ANTISLIP 22,5 x 22,5 (G 57) 8,8" x 8,8" 30
x 10 mm.

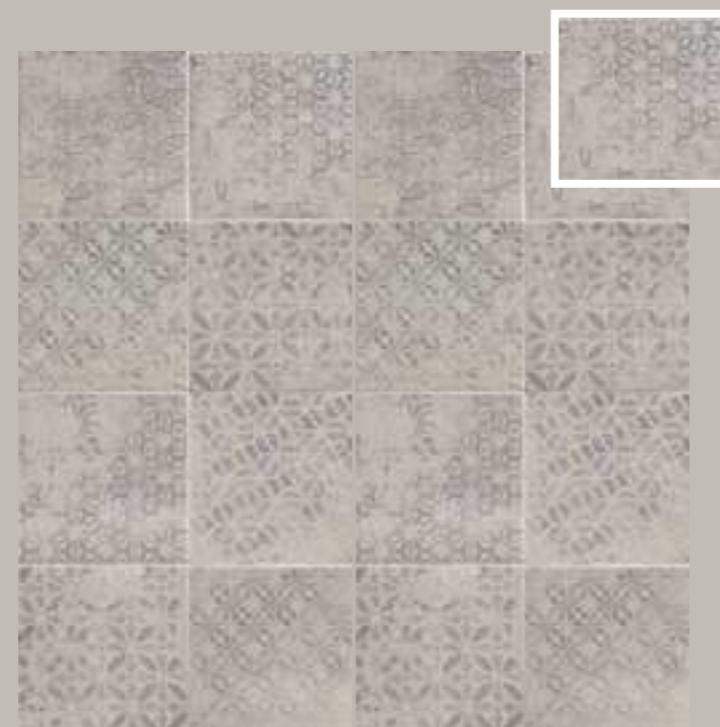

DECOR ANIMA CENIZA ANTISLIP 22,5 x 22,5 (G 57) 8,8" x 8,8" 30
x 10 mm.



DECOR ANIMA ARENA ANTISLIP 22,5 x 22,5 (G 57) 8,8" x 8,8" 30
x 10 mm.

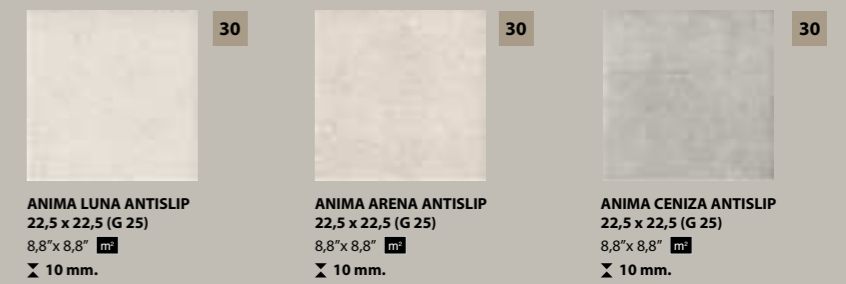

PIEZAS ESPECIALES - SPECIAL PIECES

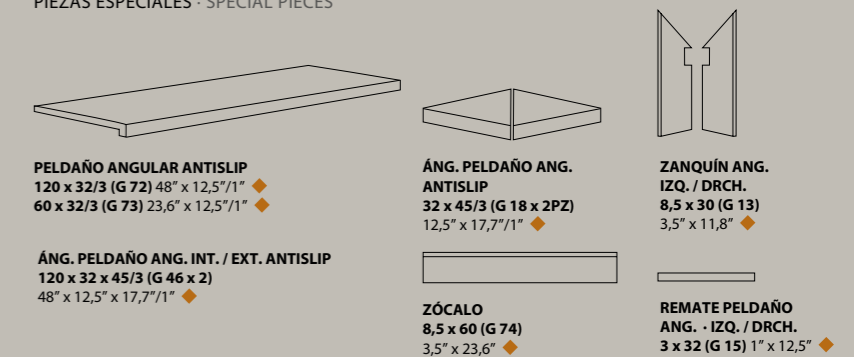

LIMESTONE

EXTRUSIONADO PORCELÁNICO
EXTRUDED PORCELAIN TILE

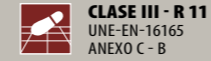

Pav. / Floor: Limestone White Antislip 60x60 - Peldaño Recto Limestone White Antislip 120x33/3



Pav. / Floor: Limestone Grey 60x60 - Limestone Grey 30x30 Peldaño Recto Limestone Grey 120x33/3 - Zócalo Recto Limestone Grey 9x30 Remate Peldaño Recto Limestone Grey 3x33



Pav. / Floor: Limestone Beige Antislip 60x60 - Limestone Beige Antislip 30x30



Rev. / Wall: Star Limestone Taupe 15,5x15,5 - Cross Limestone Taupe 15,5x15,5



LIMESTONE WHITE
LIMESTONE WHITE ANTISLIP



LIMESTONE GREY
LIMESTONE GREY ANTISLIP



LIMESTONE GREY
LIMESTONE GREY ANTISLIP



LIMESTONE TAUPE
LIMESTONE TAUPE ANTISLIP

PIEZAS ESPECIALES - SPECIAL PIECES

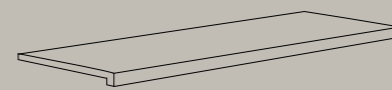

**PELDAÑO RECTO
PELDAÑO RECTO ANTISLIP**
120 x 33/3 (G 72) 48" x 13 7/11"
60 x 33/3 (G 73) 23,6" x 13 7/11"

**REMATÉ PELDAÑO
RECTO - IZQ. / DRCH.**
3 x 33 (G 15) 1" x 13"

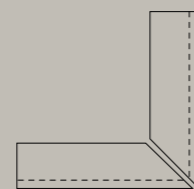

**ÁNG. PELDAÑO RECTO EXT.
ÁNG. PELDAÑO RECTO EXT.
ANTISLIP**
120 x 32 x 45/3 (G 46 x 2)
48" x 12,5" x 17,7 1/11"

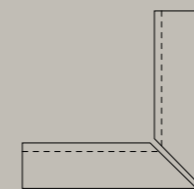

**ÁNG. PELDAÑO RECTO INT.
ÁNG. PELDAÑO RECTO INT.
ANTISLIP**
120 x 32 x 45/3 (G 46 x 2)
48" x 12,5" x 17,7 1/11"



**ZANQUÍN RCT.
IZQ. / DCHA.**
9 x 30 (G 10)
3,5" x 11,8"



**ÁNG. PELDAÑO RECTO
ÁNG. PELDAÑO RECTO ANTISLIP**
33 x 45/3 (G 18 x 2PZ)
13" x 17,7 1/11"



VIERTEGUAS ANTISLIP
15 x 30/4 (G 12)
5,9" x 11,8 1/5"



ZÓCALO
9 x 30 (G 06)
3,5" x 11,8"

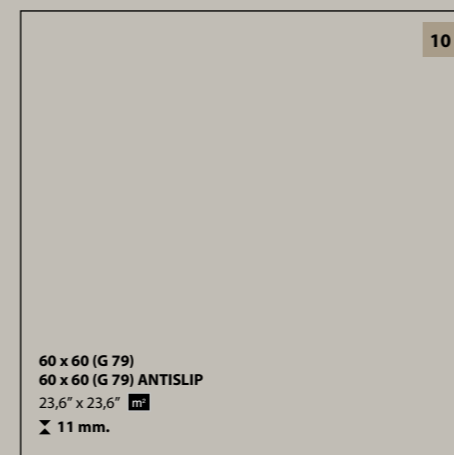

60 x 60 (G 79)
60 x 60 (G 79) ANTISLIP
23,6" x 23,6" m^2
± 11 mm.

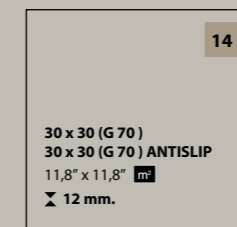

30 x 30 (G 70)
30 x 30 (G 70) ANTISLIP
11,8" x 11,8" m^2
± 12 mm.

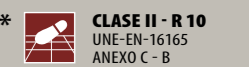

STAR
15,5 x 15,5 (G 84)
6" x 6" m^2
± 10 mm.

CROSS
15,5 x 15,5 (G 84)
6" x 6" m^2
± 10 mm.

ALPES

PORCELÁNICO RECTIFICADO
RECTIFIED PORCELAIN TILE

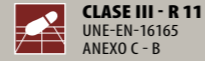

Pav. / Floor: **Alpes Blanc 60x120**



Pav. / Floor: **Alpes Creme Antislip 60x120** - Desbordante **Alpes Creme Antislip 30,5x50/2,4**
Esquina Int. Desbordante **Alpes Creme Antislip 30,5x50x40/2,4** - Grating **Alpes Creme Antislip 25x50/2,2**
Ángulo Grating **Alpes Creme Antislip 25x50x35/2,2** - Peldaño Angular **Alpes Creme Antislip 120x32/3**
Frontal **Alpes Creme 15x120** - Rev. / Wall: **Alpes Creme 60x120**



Rev. / Wall: **Alpes Pierre 60x120**
Pav. / Floor: **Alpes Pierre 60x120** - Frontal **Alpes Pierre 15x120** - Peldaño Angular **Alpes Pierre 120x32/3**



ALPES BLANC 60 x 120 (G 86) 23,6" x 48" **10**
ALPES BLANC 60 x 120 (G 79) ANTISLIP 23,6" x 48"
✂ 9 mm.



ALPES CREME 60 x 120 (G 86) 23,6" x 48" **10**
ALPES CREME 60 x 120 (G 79) ANTISLIP 23,6" x 48"
✂ 9 mm.



ALPES PIERRE 60 x 120 (G 86) 23,6" x 48" **10**
ALPES PIERRE 60 x 120 (G 79) ANTISLIP 23,6" x 48"
✂ 9 mm.

EXTRUSIONADO PORCELÁNICO EXTRUDED PORCELAIN TILE

PIEZAS ESPECIALES · SPECIAL PIECES

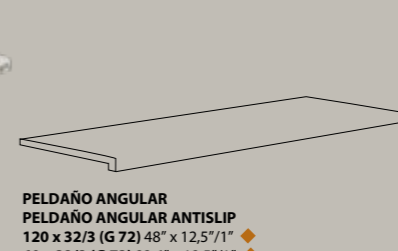

PELDAÑO ANGULAR
PELDAÑO ANGULAR ANTISLIP
120 x 32/3 (G 72) 48" x 12,5"/1"
60 x 32/3 (G 73) 23,6" x 12,5"/1"

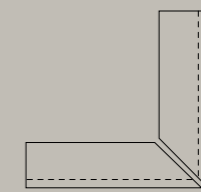

ÁNG. PELDAÑO ANG. EXT.
ÁNG. PELDAÑO ANG. EXT. ANTISLIP
120 x 32 x 45/3 (G 46 x 2)
48" x 12,5" x 17,7"/1"

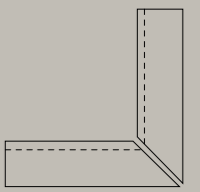

ÁNG. PELDAÑO ANG. INT.
ÁNG. PELDAÑO ANG. INT. ANTISLIP
120 x 32 x 45/3 (G 46 x 2)
48" x 12,5" x 17,7"/1"

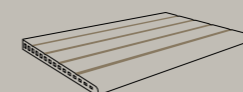

DESBORDANTE ANTISLIP
30,5 x 50/2,4 (G 80)
11,8" x 20"/1"

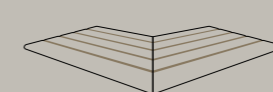

ESQUINA EXT.
DESBORDANTE ANTISLIP
30,5 x 50 x 40/2,4 (G 56 x 2PZ)
11,8" x 20" x 16"/1"



ESQUINA INT.
DESBORDANTE ANTISLIP
30,5 x 50 x 40/2,4 (G 56 x 2PZ)
11,8" x 20" x 16"/1"

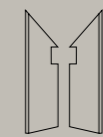

ZANQUÍN ANG.
IZQ. / DCHA.
9,8 x 30 (G 12)
3,9" x 11,8"

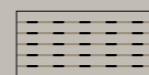

GRATTING ANTISLIP
25 x 50/2,2 (G 78) 10" x 20"/1"



ÁNG. GRATTING ANTISLIP
25 x 50 x 35/2,2 (G 60 x 2PZ)
10" x 20" x 15"/1"



SISTEMA GRATTING SIN IMPACTO
NON IMPACT GRATTING SYSTEM
SYSTÈME DE GRATTEGE SANS IMPACT



GOMA PARA GRATTING
GRATTING RUBBER 22,5 x 1,7 - 8,8" x 0,4"
(SE NECESITAN 2 ud. POR GRATTING)

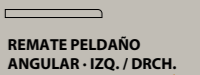

REMATE PELDAÑO
ANGULAR · IZQ. / DRCH.
3 x 32 (G 15) 1" x 12,5"

FRONTAL
15 x 120 (G 74) 6" x 48"

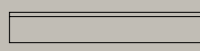

ZÓCALO
9,8 x 120 (G 74) 3,9" x 48"
9,8 x 60 (G 75) 3,9" x 23,6"



Pav. / Floor: Olimpo Grigio 60x120 · Peldaño Angular Olimpo Grigio 120x32/3 · Frontal Olimpo Grigio 15x120 · Remate Peldaño Ang. · Izq./Drch. Olimpo Grigio 3x32



Pav. / Floor: Olimpo Taupe 60x120
Rev. / Wall: Olimpo Taupe 60x120



OLIMPO GRIGIO 60 x 120 (G 86) 23,6" x 48" **7**
OLIMPO GRIGIO 60 x 120 (G 79) ANTISLIP 23,6" x 48"
✂ 9 mm.

OLIMPO CREMA 60 x 120 (G 86) 23,6" x 48" **7**
OLIMPO CREMA 60 x 120 (G 79) ANTISLIP 23,6" x 48"
✂ 9 mm.

OLIMPO TAUPE 60 x 120 (G 86) 23,6" x 48" **7**
OLIMPO TAUPE 60 x 120 (G 79) ANTISLIP 23,6" x 48"
✂ 9 mm.

EXTRUSIONADO PORCELÁNICO PIEZAS ESPECIALES · SPECIAL PIECES
EXTRUDED PORCELAIN TILE

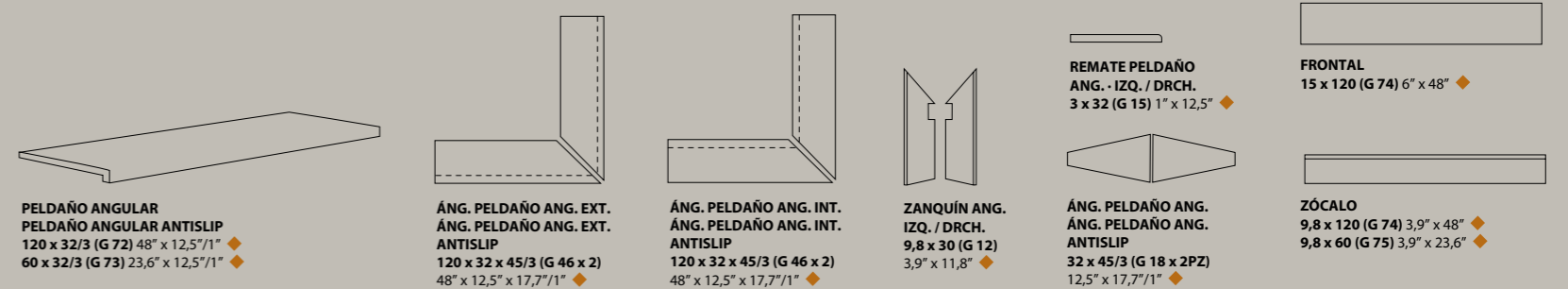

POSETS

PORCELÁNICO RECTIFICADO
RECTIFIED PORCELAIN TILE

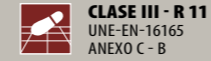

Pav. / Floor: Posets Blanco Antislip 60x120 · Peldaño Angular Posets Blanco Antislip 120x32/3 · Frontal Posets Blanco 15x120 · Ángulo Peldaño int. Posets Blanco Antislip 120x32x45/3



Pav. / Floor: Posets Beige 60x120 · Peldaño Angular Posets Beige 120x32/3 · Frontal Posets Beige 15x120 · Remate Peldaño Angular drch. Posets Beige 3x32
Rev. / Wall: Posets Beige 60x120



POSETS BLANCO 60 x 120 (G 86) 23,6" x 48" m^2 20
POSETS BLANCO 60 x 120 (G 79) ANTISLIP 23,6" x 48" m^2
± 9 mm.



POSETS BEIGE 60 x 120 (G 86) 23,6" x 48" m^2 20
POSETS BEIGE 60 x 120 (G 79) ANTISLIP 23,6" x 48" m^2
± 9 mm.

EXTRUSIONADO PORCELÁNICO EXTRUDED PORCELAIN TILE

PIEZAS ESPECIALES · SPECIAL PIECES

| | | | | | |
|--|--|--|---|--|---|
| | PELDAÑO ANGULAR PELDAÑO ANGULAR ANTISLIP 120 x 32/3 (G 72) 48" x 12,5"/1" 60 x 32/3 (G 73) 23,6" x 12,5"/1" | | ÁNG. PELDAÑO ANG. EXT. ÁNG. PELDAÑO ANG. EXT. ANTISLIP 120 x 32 x 45/3 (G 46 x 2) 48" x 12,5" x 17,7"/1" | | ÁNG. PELDAÑO ANG. INT. ÁNG. PELDAÑO ANG. INT. ANTISLIP 120 x 32 x 45/3 (G 46 x 2) 48" x 12,5" x 17,7"/1" |
| | REMATE PELDAÑO ANGULAR · IZQ. / DRCH. 3 x 32 (G 15) 1" x 12,5" | | ZÓCALO 9,8 x 120 (G 74) 3,9" x 48" 9,8 x 60 (G 75) 3,9" x 23,6" | | FRONTAL 15 x 120 (G 74) 6" x 48" |
| | BORDE PISCINA ANTISLIP 28 x 66,5/4 (G 80) 10" x 26,5"/1,5" | | ESQ. INT. BORDE PISCINA ANTISLIP 28 x 66,5 x 43/4 (G 56 x 2PZ) 10" x 26,5" x 17"/1,5" | | ESQ. EXT. BORDE PISCINA 28 x 66,5 x 43/4 (G 56 x 2PZ) 10" x 26,5" x 17"/1,5" |
| | | | ZANQUÍN ANG. · IZQ. / DRCH. 9,8 x 30 (G 12) 3,9" x 11,8" | | ÁNG. PELDAÑO ANG. ÁNG. PELDAÑO ANG. ANTISLIP 32 x 45/3 (G 18 x 2PZ) 12,5" x 17,7"/1" |

POSETS ANTISLIP

EXTRUSIONADO PORCELÁNICO
EXTRUDED PORCELAIN TILE

CLASE III - R 11
UNE-EN-16165
ANEXO C - B



Pav. / Floor: Posets Gris Antislip 36x72 · Borde Piscina Posets Gris Antislip 28x66,5/4 · Esquina Interior Borde Piscina Posets Gris Antislip 28x66,5x43/4 · Peldaño Angular Posets Gris Antislip 120x32/3



Pav. / Floor: Posets Beige Antislip 18x36 · Posets Beige Antislip 36x36 · Posets Beige Antislip 36x72 · Peldaño Angular Posets Beige Antislip 120x32/3 · Ángulo Peldaño Angular Posets Beige Antislip 120x32x45/3
Rev. / Wall: Posets Beige 60x120

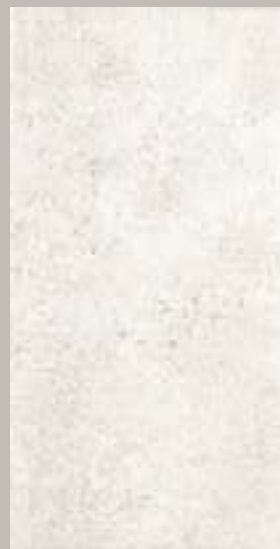

POSETS BLANCO ANTISLIP



POSETS DECO BLANCO ANTISLIP



POSETS GRIS ANTISLIP



POSETS DECO GRIS ANTISLIP



POSETS BEIGE ANTISLIP



POSETS DECO BEIGE ANTISLIP

PIEZAS ESPECIALES · SPECIAL PIECES

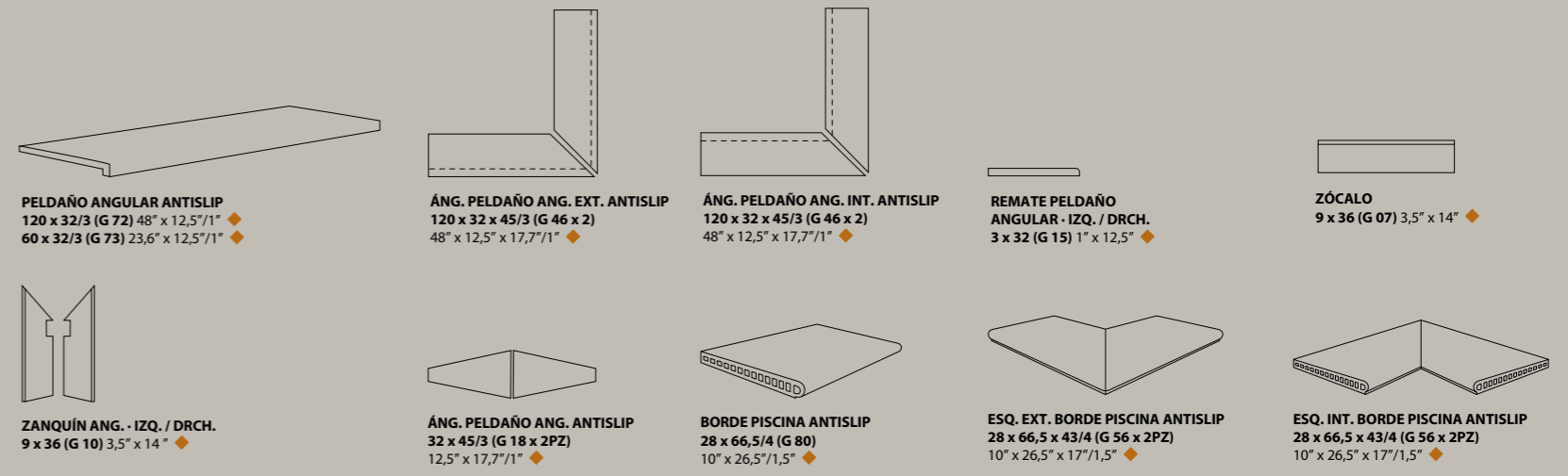

IDEAS DE COLOCACIÓN 18 x 36 · 36 x 36 · 36 x 72 · INSTALLATIONS IDEAS 7" x 14" · 14" x 14" · 14" x 28"

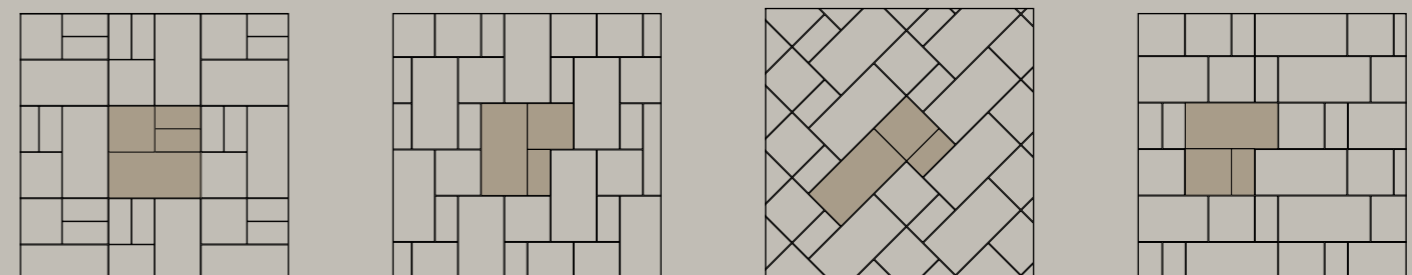

| | | | |
|--|--|---|---|
| 10 | 10 | 20 | 20 |
| <p>36 x 72 (G 86) ANTISLIP 14" x 28" m^2 9 mm.</p> | <p>36 x 36 (G 57) ANTISLIP 14" x 14" m^2 9 mm.</p> | <p>18 x 36 (G 57) ANTISLIP 7" x 14" m^2 9 mm.</p> | <p>DECO 18 x 18 (G 86) ANTISLIP 7" x 7" m^2 9 mm.</p> |

PIEDRAS DEL BRUC

EXTRUSIONADO PORCELÁNICO
EXTRUDED PORCELAIN TILE

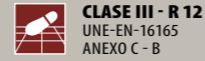

Pav. / Floor: Piedras del Bruc Gris Antislip 45x67,5 - Peldaño Angular Piedras del Bruc Gris Antislip 67,5x32/3 - Ángulo Peldaño int. Piedras del Bruc Gris Antislip 67,5x32x45/3



Pav. / Floor: Piedras del Bruc Beige Antislip 22,5x67,5 - Peldaño Angular Piedras del Bruc Beige Antislip 67,5x32/3



PIEDRAS DEL BRUC BLANCO
PIEDRAS DEL BRUC BLANCO ANTISLIP



PIEDRAS DEL BRUC GRIS
PIEDRAS DEL BRUC GRIS ANTISLIP



PIEDRAS DEL BRUC BEIGE
PIEDRAS DEL BRUC BEIGE ANTISLIP



45 x 67,5 (G 86)
45 x 67,5 (G 86) ANTISLIP
17,7" x 26,5"
12 mm.



22,5 x 67,5 (G 86) ANTISLIP
8,8" x 26,5"
12 mm.

PIEZAS ESPECIALES - SPECIAL PIECES



PELDAÑO ANGULAR
PELDAÑO ANGULAR ANTISLIP
67,5 x 32/3 (G 80) 26,5" x 12,5"/1"

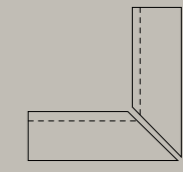

ÁNG. PELDAÑO ANG. INT.
ÁNG. PELDAÑO ANG. INT. ANTISLIP
67,5 x 32 x 45/3 (G 56 x 2)
26,5" x 12,5" x 17,7"/1"

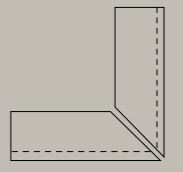

ÁNG. PELDAÑO ANG. EXT.
ÁNG. PELDAÑO ANG. EXT. ANTISLIP
67,5 x 32 x 45/3 (G 56 x 2)
26,5" x 12,5" x 17,7"/1"

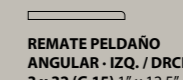

REMATE PELDAÑO
ANGULAR - IZQ. / DRCH.
3 x 32 (G 15) 1" x 12,5"



ZANQUÍN ANG. - IZQ. / DRCH.
9 x 45 (G 12) 3,5" x 17,7"

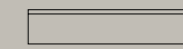

ZÓCALO
9 x 45 (G 10) 3,5" x 17,7"



ZANQUÍN ANG. - IZQ. / DRCH.
9 x 45 (G 12) 3,5" x 17,7"

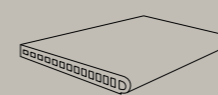

BORDE PISCINA ANTISLIP
28 x 66,5/4 (G 80)
10" x 26,5"/1,5"

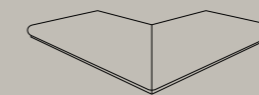

ESQ. EXT. BORDE PISCINA ANTISLIP
28 x 66,5 x 43/4 (G 56 x 2PZ)
10" x 26,5" x 17"/1,5"

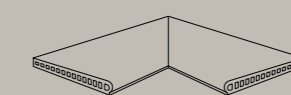

ESQ. INT. BORDE PISCINA ANTISLIP
28 x 66,5 x 43/4 (G 56 x 2PZ)
10" x 26,5" x 17"/1,5"

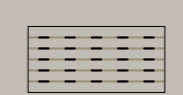

GRATTING ANTISLIP
25 x 50/2,2 (G 78) 10" x 20"/1"

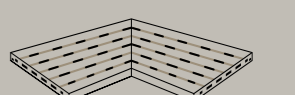

ÁNG. GRATTING ANTISLIP
25 x 50 x 35/2,2 (G 60 x 2PZ)
10" x 20" x 15"/1"

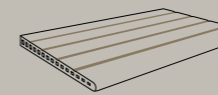

DESBORDANTE ANTISLIP
30,5 x 50/2,4 (G 80)
11,8" x 20"/1"

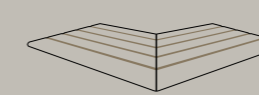

ESQ. EXT. DESBORDANTE ANTISLIP
30,5 x 50 x 40/2,4 (G 56 x 2PZ)
11,8" x 20" x 16"/1"

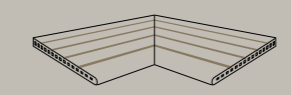

ESQ. INT. DESBORDANTE ANTISLIP
30,5 x 50 x 40/2,4 (G 56 x 2PZ)
11,8" x 20" x 16"/1"



GOMA PARA GRATTING
GRATTING RUBBER 22,5 x 1,7 - 8,8" x 0,4"
(SE NECESITAN 2 ud. POR GRATTING)



SISTEMA GRATTING SIN IMPACTO
NON IMPACT GRATTING SYSTEM
SYSTÈME DE GRATTEGE SANS IMPACT

PIRINEOS

PORCELÁNICO
PORCELAIN TILE

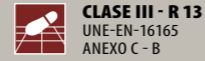

Pav. / Floor: Borde Piscina Pirineos Mix Antislip 28x66,5/4 - Esquina int. Borde Piscina Pirineos Mix Antislip 28x66,5x43/4 - Natur-Tech Central Park Antislip 20x90/2,6
Vaso Piscina / Pool Basin: Pirineos Mix Antislip 15x15



Pav. / Floor: Pirineos Blanco Antislip 33x66,5 - Peldaño Angular Pirineos Blanco Antislip 66,5x32/3
Vaso Piscina / Pool Basin: Pirineos Mix Antislip 15x15

MATE
MATT
PORCELÁNICO
PORCELAIN TILE



PIRINEOS BLANCO ANTISLIP
33 x 66,5 (G 90)
13" x 26,5"
x 9 mm.

10

PIRINEOS BEIGE ANTISLIP
33 x 66,5 (G 90)
13" x 26,5"
x 9 mm.

10

PIRINEOS GRIS ANTISLIP
33 x 66,5 (G 90)
13" x 26,5"
x 9 mm.

10

PIRINEOS MIX ANTISLIP
33 x 66,5 (G 90)
13" x 26,5"
x 9 mm.

10

MATE
MATT
EXTRUSIONADO PORCELÁNICO
EXTRUDED PORCELAIN TILE



PIRINEOS MIX ANTISLIP
*15 x 15 (G 79) 6" x 6" - CLASE III - R13
x 9 mm.

10

BRILLO
GLOSS
EXTRUSIONADO PORCELÁNICO
EXTRUDED PORCELAIN TILE



PIRINEOS MIX
*15 x 15 (G 79) 6" x 6" - CLASE I - R9
x 9 mm.

10

EXTRUSIONADO PORCELÁNICO
EXTRUDED PORCELAIN TILE

PIEZAS ESPECIALES - SPECIAL PIECES

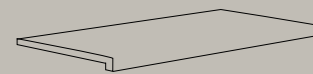

PELDAÑO ANGULAR
PELDAÑO ANGULAR ANTISLIP
66,5 x 32/3 (G 80) 26,5" x 12,5"/1"



ÁNG. PELDAÑO ANG.
ÁNG. PELDAÑO ANG. ANTISLIP
66,5 x 32 x 45/3 (G 56 x 2PZ)
26,5" x 12,5" x 17,7"/1"



ZÓCALO
9,8 x 66,5 (G 75) 3,9" x 26,5"

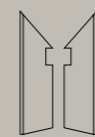

ZANQUÍN ANG. - IZQ. / DRCH.
9,8 x 30 (G 12) 3,9" x 11,8"



BORDE PISCINA ANTISLIP
28 x 66,5/4 (G 80) 10" x 26,5"/1,5"



ESQ. INT. BORDE PISCINA ANTISLIP
28 x 66,5 x 43/4 (G 56 x 2PZ)
10" x 26,5" x 17,7"/1,5"



ESQ. EXT. BORDE PISCINA ANTISLIP
28 x 66,5 x 43/4 (G 56 x 2PZ)
10" x 26,5" x 17,7"/1,5"



Pav. / Floor: Tech Geo Volcano Antislip 11x22,5 · Tech Geo Volcano Antislip 22,5x22,5 · Tech Geo Volcano Antislip 22,5x33 · Peldaño Curvo Tech Geo Volcano Antislip 22,5x33/4



Pav. / Floor: Tech Geo Mountain Antislip 11x22,5 · Tech Geo Mountain Antislip 22,5x33



TECH GEO GLACIER ANTISLIP



TECH GEO MOUNTAIN ANTISLIP



TECH GEO RIVER ANTISLIP



TECH GEO VOLCANO ANTISLIP



Pav. / Floor: Tech Geo Glacier Antislip 11x22,5 · Tech Geo Glacier Antislip 22,5x22,5



TECH GEO GLACIER 22,5 x 33 · 8,8" x 13"
TECH GEO GLACIER 22,5 x 22,5 · 8,8" x 8,8"
TECH GEO GLACIER 11 x 22,5 · 4,3" x 8,8"



TECH GEO RIVER 22,5 x 22,5 · 8,8" x 8,8"
TECH GEO RIVER 11 x 22,5 · 4,3" x 8,8"



TECH GEO MOUNTAIN 22,5 x 33 · 8,8" x 13"
TECH GEO MOUNTAIN 22,5 x 22,5 · 8,8" x 8,8"
TECH GEO MOUNTAIN 11 x 22,5 · 4,3" x 8,8"



TECH GEO VOLCANO 22,5 x 22,5 · 8,8" x 8,8"
TECH GEO VOLCANO 11 x 22,5 · 4,3" x 8,8"

ESPECIFICACIONES TÉCNICAS · TECHNICAL SPECIFICATIONS



RESISTE LA FLEXIÓN 32 N/mm² RESISTE EL DESGASTE PEI (II-IV) RESISTE EL RAYADO MOHS - 8-9 MANCHAS Clase 5 - Clase A ABSORCIÓN 0,1% DILATACIÓN 6,6" 10" / °C CARGA DE ROTURA 3546 Nw

PIEZAS ESPECIALES · SPECIAL PIECES

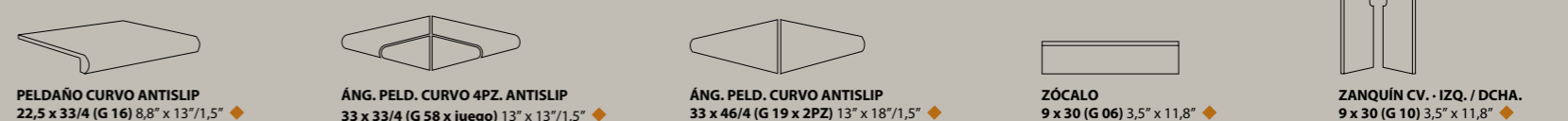

PELDAÑO CURVO ANTISLIP 22,5 x 33/4 (G 16) 8,8" x 13"/1,5" ♦️ ÁNG. PELD. CURVO 4PZ. ANTISLIP 33 x 33/4 (G 58 x juego) 13" x 13"/1,5" ♦️ ÁNG. PELD. CURVO ANTISLIP 33 x 46/4 (G 19 x 2PZ) 13" x 18"/1,5" ♦️ ZÓCALO 9 x 30 (G 06) 3,5" x 11,8" ♦️ ZANQUÍN CV. - IZQ. / DCHA. 9 x 30 (G 10) 3,5" x 11,8" ♦️

NATUR 2.0 TRANSIT

EXTRUSIONADO PORCELÁNICO
EXTRUDED PORCELAIN TILE

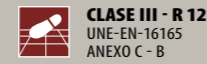

Pav. / Floor: Transit Frost 2.0 Antislip 20x30 · Canaleta Con Desagüe Transit Frost 2.0 15x20x2
Zócalo Transit Frost 2.0 9x30



Pav. / Floor: Transit P. Mix 2.0 Antislip 20x20 · Transit P. Mix 2.0 Antislip 20x30



Pav. / Floor: Transit B. East 2.0 Antislip 20x20 · Zócalo Angular Transit B. East 2.0 6x30x4 · Peldaño Curvo Transit B. East Antislip 2.0 36x33/4 · Canaleta Transit B. East 2.0 15x20/2 · Canaleta Con Desagüe Transit B. East 2.0 15x20/2
Rev. / Wall: Transit B. East 2.0 Antislip 20x20



TRANSIT TOBACCO 2.0 ANTISLIP



TRANSIT B. EAST 2.0 ANTISLIP



TRANSIT B. NORTH 2.0 ANTISLIP

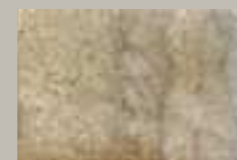

TRANSIT P. MIX 2.0 ANTISLIP

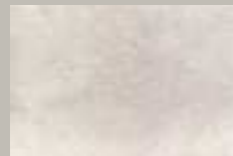

TRANSIT FROST 2.0 ANTISLIP



TRANSIT CLOUD 2.0 ANTISLIP



TRANSIT DARK 2.0 ANTISLIP

ESPECIFICACIONES TÉCNICAS · TECHNICAL SPECIFICATIONS



RESISTE LA FLEXIÓN
≥ 33 N/mm²



RESISTE EL DESGASTE
PEI IV



RESISTE EL RAYADO
MOHS - 8

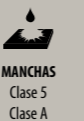

MANCHAS
Clase 5
Clase A

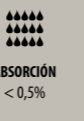

ABSORCIÓN
< 0,5%



DILATACIÓN
6,0* 10⁻⁴ / °C

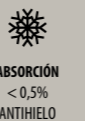

ABSORCIÓN
< 0,5%
ANTHIELO



F. ROTURA
8000Nw

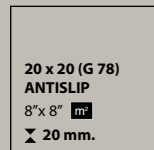

30

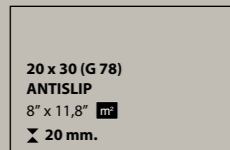

16

PAVIMENTO DE ALTO RENDIMIENTO · HIGH PERFORMANCE FLOOR TILE

APLICACIONES · APPLICATIONS



* NO apto para usar sobre PLOTS
* NOT suitable for use on PLOTS



ÁREAS RESIDENCIALES
RESIDENTIAL AREAS



ZONAS URBANAS
URBAN AREAS



TERRAZAS Y PATIOS
TERRACE & PATIOS



ZONAS COMERCIALES
COMMERCIAL AREAS



ZONAS DE ALTO TRÁNSITO
HIGH TRAFFIC AREAS



PISCINAS
SWIMMING POOLS



JARDINES
GARDENS



ÁREAS INDUSTRIALES
INDUSTRIAL AREAS



ZONAS DE ALTAS
EXIGENCIAS HIGIÉNICAS
HIGH AREAS
HYGIENIC REQUIREMENTS

NATUR 2.0 TRANSIT

EXTRUSIONADO PORCELÁNICO
EXTRUDED PORCELAIN TILE

CLASE III - R 12
UNE-EN-16165
ANEXO C - B

≥60
DCOF

CLASS C
UNE-EN-16165
ANEXO A

20 mm
ESPESOR
THICKNESS

RE SPECIAL ORDER
BAJO PEDIDO



Pav. / Floor: Transit Tobacco 2.0 Antislip 20x20 · Transit Tobacco 2.0 Antislip 20x30



Pav. / Floor: Transit B. North 2.0 Antislip 20x20 · Transit B. North 2.0 Antislip 20x30 · Zócalo Transit B. North 9x36
Stop Transit Frost 2.0 20x20 · Go Transit Frost 2.0 20x20 · Peldaño Curvo Transit B. North Antislip 36x33/4
Rev. / Wall: Boston Brick Downtown Trab. Enm 25x50



Pav. / Floor: Transit Cloud 2.0 Antislip 20x30 · Stop Transit Dark 2.0 20x20 3 · Go Transit Dark 2.0 20x20 · Peldaño Angular Transit Cloud 2.0 Antislip 66,5x32/3

Disponible en FROST, CLOUD y DARK
Available in FROST, CLOUD and DARK

Disponible en todos los colores
Available in all colors

Piezas Especiales Podotáctiles
Special podotactile pieces



STOP
20 x 20 (G 91) 8" x 8"



GO
20 x 20 (G 91) 8" x 8"



CANALETA ANTISLIP
15 x 20/2 (G 92) 5,9" x 8"/1"



CANALETA CON DESAGÜE ANTISLIP
15 x 20/2 (G 38) 5,9" x 8"/1"



ABSORCION
<0,5%



CLASE 5 - CLASE A
Resistente a las manchas
Stain resistant



A/LA/HA
Resistencia química
Chemical resistance

Disponble en B. EAST y B. NORTH
Available in B. EAST and B. NORTH



PELDAÑO CURVO ANTISLIP
22,5 x 33/4 (G 16) 8,8" x 13"/1,5"
36 x 33/4 (G 18) 14" x 13"/1,5"



ÁNG. PELD. CURVO ANTISLIP
33 x 46/4 (G 19 x 2PZ)
13" x 18"/1,5"



ZANQUÍN CV. IZQ. / DRCH.
9 x 36 (G 10) 3,5" x 14"



VIERTEAGUAS ANTISLIP
15 x 22,5/4 (G 10)
5,9" x 8,8"/1,5"



ZÓCALO
9 x 36 (G 07) 3,5" x 14"

Disponble en FROST, CLOUD, TOBACCO, P. MIX y DARK
Available in FROST, CLOUD, TOBACCO, P. MIX and DARK

Disponble en FROST, CLOUD, TOBACCO y DARK
Available in FROST, CLOUD, TOBACCO and DARK



PELDAÑO ANG. ANTISLIP
66,5 x 32/3 (G 80)
26,5" x 12,5"/1"



ÁNG. PELDAÑO ANG. ANTISLIP
66,5 x 32 x 45/3 (G 56 x 2PZ)
26,5" x 12,5" x 17,7"/1"

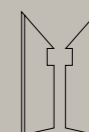

ZANQUÍN ANG. IZQ. / DRCH.
9 x 30 (G 10) 3,5" x 11,8"

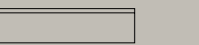

ZÓCALO
9 x 30 (G 06) 3,5" x 11,8"

Disponble en FROST, B. EAST y P. MIX
Available in FROST, B. EAST and P. MIX

Disponble en P. MIX
Available in P. MIX



ZÓCALO ANGULAR
6 x 30 x 4 (G 74)
2,5" x 11,8" x 1,5"



MEDIA CAÑA INT.
4 x 30 x 4 (G 13)
1,5" x 11,8" x 1,5"



CUBRECANTO
4 x 30 x 4 (G 15)
1,5" x 11,8" x 1,5"



COMP. EXT.
MEDIA CAÑA
4 x 4 (G 17)
1,5" x 1,5"



COMP. INT.
MEDIA CAÑA
4 x 4 (G 17)
1,5" x 1,5"



COMP. INT.
CUBRECANTO
4 x 4 (G 17)
1,5" x 1,5"



COMP. EXT.
CUBRECANTO
4 x 4 (G 17)
1,5" x 1,5"



COMP. EXT.
ZÓCALO ANG.
6 x 4 (G 85)
2,5" x 1,5"



COMP. INT.
ZÓCALO ANG.
6 x 4 (G 85)
2,5" x 1,5"



ZÓCALO
9,8 x 66,5 (G 75)
3,9" x 26,5"



ZANQUÍN ANG. IZQ. / DRCH.
9,8 x 30 (G 12) 3,9" x 11,8"

NATUR-TECH

PAVIMENTO DRENANTE DE EXTERIOR

EXTRUSIONADO PORCELÁNICO
EXTRUDED PORCELAIN TILE

CLASE III - R 11
UNE-EN-16165
ANEXO C - B

26 mm
ESPESOR
THICKNESS



Pav. / Floor: Natur-Tech Piedras del Bruc Blanco Antislip 20x90/2,6
Remate Triángulo Natur-Tech Piedras del Bruc Blanco Antislip 20x6,5/2,6



Pav. / Floor: Natur-Tech Natura Sand Antislip 20x90/2,6
Remate Triángulo Natur-Tech Natura Sand Antislip 20x6,5/2,6
Rev. / Wall: Natur-Tech Natura Sand Antislip 20x90/2,6



Pav. / Floor: Natur-Tech Natura Camel Antislip 20x90/2,6 - Peldaño Angular Natura Camel Antislip 120x32/3 - Ángulo Peldaño Int. Natura Camel Antislip 120x32x45/3

PIEZAS ESPECIALES · SPECIAL PIECES



REMATE ANGULAR NATUR-TECH ANTISLIP
20 x 90/2,6 (G 90) 8" x 35,4"/1"
20 x 45/2,6 (G 17) 8" x 17,7"/1"



REMATE TRIÁNGULO NATURTECH ANTISLIP
20 x 6,5/2,6 (G 16) 8" x 2,5"/1"

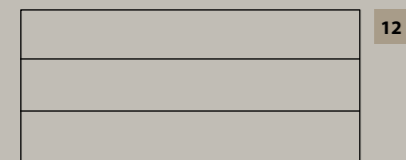

20 x 45/2,6 (G 84) ANTISLIP 8" x 17,7"/1" m²
26 mm.



20 x 90/2,6 (G 89) ANTISLIP 8" x 35,4"/1" m²
26 mm.

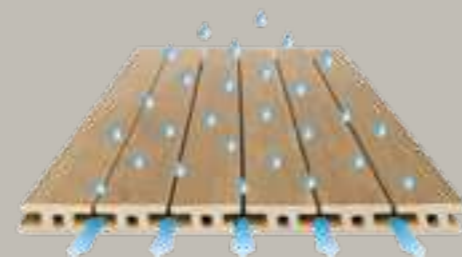

PAVIMENTO DRENANTE DE EXTERIOR
OUTDOOR DRAINING EXTRUDED FLOOR

NATUR-TECH



GUÍA DE COLOCACIÓN
INSTALLATION GUIDE

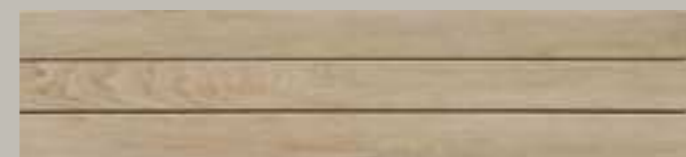

NATUR-TECH NATURA SAND ANTISLIP



NATUR-TECH NATURA CAMEL ANTISLIP



NATUR-TECH HYDE PARK ANTISLIP

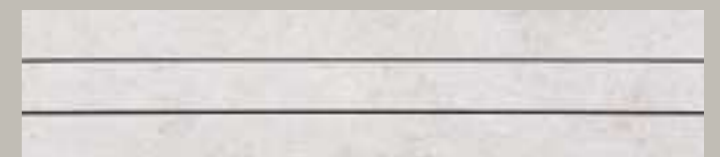

NATUR-TECH PIEDRAS DEL BRUC BLANCO ANTISLIP

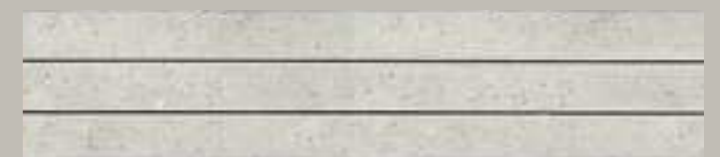

NATUR-TECH PIEDRAS DEL BRUC GRIS ANTISLIP



NATUR-TECH CENTRAL PARK ANTISLIP



Sherwood Nut 20 x 120

SHERWOOD, la fuerza natural de la madera.
SHERWOOD, the natural strength of wood.



SHERWOOD



NATUCER
cerámica natural

NEW
2026

SHERWOOD

La serie SHERWOOD nace de la esencia más pura de la naturaleza. Sus texturas y tonalidades evocan la calidez de los bosques, aportando carácter, autenticidad y armonía a cualquier espacio. Una colección pensada para crear ambientes acogedores con un diseño atemporal y sofisticado.

The SHERWOOD series is born from the purest essence of nature. Its textures and tones evoke the warmth of forests, bringing character, authenticity, and harmony to any space. A collection designed to create welcoming environments with a timeless and sophisticated design.

NATUCER
cerámica natural



Pav. / Floor: Sherwood Nut 25x150 · Peldaño Recto Sherwood Nut 150x33/3 · Remate Recto Izq. Sherwood Nut 3x33
Rev. / Wall: Boston Brick South 6,5x25



Pav. / Floor: Sherwood Linde 25x150 - Peldaño Recto Sherwood Linde 120x33/3 - Frontal Sherwood Linde 15x120 - Remate Sherwood Linde Izq. / Dech. 3x33

14

20 x 120 (G 68)
20 x 120 (G 70) ANTISLIP
8"x 48"
9 mm.

14

25 x 150 (G 79)
25 x 150 (G 80) ANTISLIP
10"x 60"
10 mm.



Pav. / Floor: Sherwood Birch 20x120 - Sherwood Birch Antislip 20x120 - Zócalo Sherwood Birch 9,8x120



SHERWOOD LINDE
20 x 120 (G 68) 8"x 48"
25 x 150 (G 79) 10"x 60"

SHERWOOD LINDE ANTISLIP
20 x 120 (G 70) 8"x 48"



SHERWOOD BIRCH
20 x 120 (G 68) 8"x 48"
25 x 150 (G 79) 10"x 60"

SHERWOOD BIRCH ANTISLIP
20 x 120 (G 70) 8"x 48"
25 x 150 (G 80) 10"x 60"



SHERWOOD OAK
20 x 120 (G 68) 8"x 48"
25 x 150 (G 79) 10"x 60"

SHERWOOD OAK ANTISLIP
20 x 120 (G 70) 8"x 48"
25 x 150 (G 80) 10"x 60"



SHERWOOD NUT
20 x 120 (G 68) 8"x 48"
25 x 150 (G 79) 10"x 60"

SHERWOOD NUT ANTISLIP
20 x 120 (G 70) 8"x 48"

EXTRUSIONADO PORCELÁNICO
EXTRUDED PORCELAIN TILE



PIEZAS ESPECIALES - SPECIAL PIECES
Disponible en todos los colores - Available in all colors

CLASE I - R 9
UNE-EN-16165
ANEXO C - B

CLASE III - R 11
UNE-EN-16165
ANEXO C - B

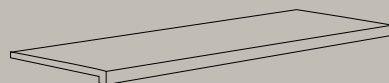

PELDAÑO RECTO
120 x 33/3 (G 72) 48" x 13"/1"
60 x 33/3 (G 73) 23,6" x 13"/1"
150 x 33/3 (G 81) 60" x 13"/1"

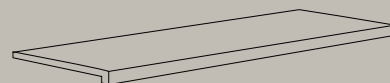

PELDAÑO RECTO ANTISLIP
120 x 33/3 (G 72) 48" x 13"/1"
60 x 33/3 (G 73) 23,6" x 13"/1"

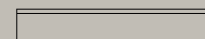

ZÓCALO
9,8 x 120 (G 74) 3,9" x 48"
9,8 x 60 (G 75) 3,9" x 23,6"



REMATE PELDAÑO RECTO IZQ. / DRCH.
3 x 33 (G 15) 1" x 13"

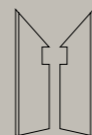

ZANQUÍN RECTO IZQ. / DRCH.
9,8 x 30 (G 13) 4" x 11,8"

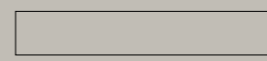

FRONTAL
15 x 120 (G 36) 6" x 48"



PIEZAS ESPECIALES - SPECIAL PIECES
Disponible en OAK y BIRCH - Available in OAK & BIRCH

CLASE I - R 9
UNE-EN-16165
ANEXO C - B

CLASE III - R 11
UNE-EN-16165
ANEXO C - B



PELDAÑO BLOCK
PELDAÑO BLOCK ANTISLIP
120 x 33/1,4 (G 79) 48" x 13"/0,5"

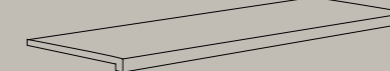

PELDAÑO RECTO
PELDAÑO RECTO ANTISLIP
150 x 33/3 (G 81) 60" x 13"/1"

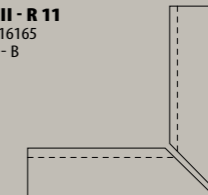

ÁNG. PELDAÑO RECTO INT.
ÁNG. PELDAÑO RECTO INT. ANTISLIP
150 x 33 x 45/3 (G 46 x 2)
60" x 13" x 17,7"/1"

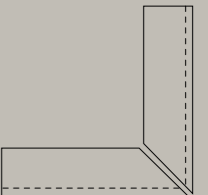

ÁNG. PELDAÑO RECTO EXT.
ÁNG. PELDAÑO RECTO EXT. ANTISLIP
150 x 33 x 45/3 (G 46 x 2)
60" x 13" x 17,7"/1"

SHERWOOD 30x180

PORCELÁNICO RECTIFICADO
RECTIFIED PORCELAIN TILE

NEW
2026

CLASE I - R 9
UNE-EN-16165
ANEXO C - B



Pav. / Floor: Sherwood Birch 25x150 · Sherwood Birch 20x120 · Sherwood Birch 30x180 · Peldaño Recto Sherwood Birch 120x33/3 · Frontal Sherwood Birch 15x120 · Remate Sherwood Birch 3x33
Rev. / Wall: Sarsen Stone Greige 60x120



Pav. / Floor: Sherwood Oak Antislip 20x120 · Peldaño Recto Sherwood Oak Antislip 120x33/3 · Frontal Sherwood Oak 15x120

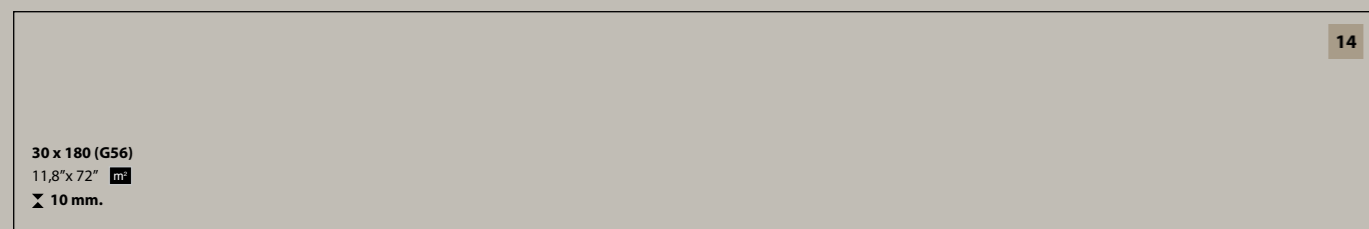

SHERWOOD OAK

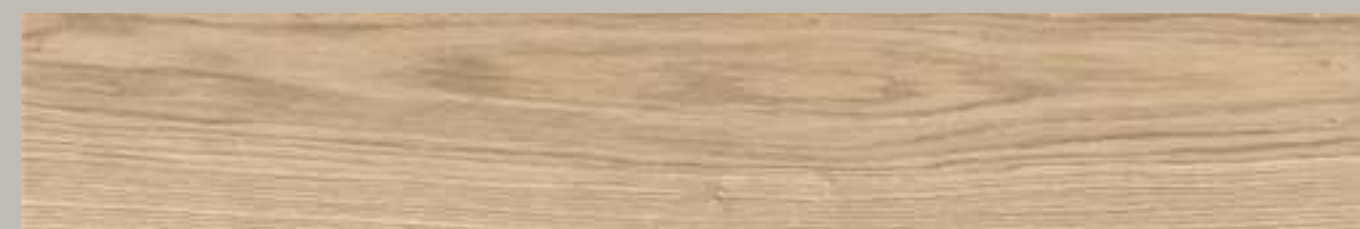

SHERWOOD BIRCH

EXTRUSIONADO PORCELÁNICO
EXTRUDED PORCELAIN TILE



PIEZAS ESPECIALES · SPECIAL PIECES
Disponible en OAK y BIRCH · Available in OAK & BIRCH

CLASE I - R 9
UNE-EN-16165
ANEXO C - B

CLASE III - R 11
UNE-EN-16165
ANEXO C - B



PELDAÑO BLOCK
PELDAÑO BLOCK ANTISLIP
120 x 33/1,4 (G 79) 48" x 13"/0,5"



PELDAÑO RECTO
PELDAÑO RECTO ANTISLIP
150 x 33/3 (G 81) 60" x 13"/1"
120 x 33/3 (G 72) 48" x 13"/1"
60 x 33/3 (G 73) 23,6" x 13"/1"

ÁNG. PELDAÑO RECTO INT. / EXT.
ÁNG. PELDAÑO RECTO INT. / EXT. ANTISLIP
120 x 33 x 45/3 (G 46 x 2) 48" x 13" x 17,7"/1"
150 x 33 x 45/3 (G 46 x 2) 60" x 13" x 17,7"/1"



ZÓCALO
9,8 x 120 (G 74) 3,9" x 48"
9,8 x 60 (G 75) 3,9" x 23,6"



REMATE PELDAÑO RECTO IZQ. / DRCH.
3 x 33 (G 15) 1" x 13"

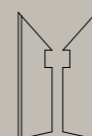

ZANQUÍN RCT. IZQ. / DRCH.
9,8 x 30 (G 13) 4" x 11,8"



FRONTAL
15 x 120 (G 36) 6" x 48"



Pav. / Floor: Zermatt Honey Antislip 25x150 - Peldaño Recto Zermatt Honey Antislip 120x33/3
Ángulo Peldaño Recto Int. Zermatt Honey Antislip 120x33/3



Pav. / Floor: Zermatt Natural 25x150



Pav. / Floor: Zermatt Walnut 25x150

18

25 x 150 (G 79)
25 x 150 (G 80) ANTISLIP
10" x 60" m^2
± 10 mm.



ZERMATT HONEY
ZERMATT HONEY ANTISLIP



ZERMATT NATURAL
ZERMATT NATURAL ANTISLIP



ZERMATT WALNUT
ZERMATT WALNUT ANTISLIP

EXTRUSIONADO PORCELÁNICO
EXTRUDED PORCELAIN TILE

PIEZAS ESPECIALES · SPECIAL PIECES

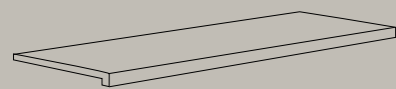

PELDAÑO RECTO
PELDAÑO RECTO ANTISLIP
150 x 33/3 (G 81) 60" x 13 7/16"
120 x 33/3 (G 72) 48" x 13 7/16"
60 x 33/3 (G 73) 23,6" x 13 7/16"

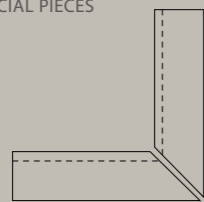

ÁNG. PELDAÑO RECTO INT.
ÁNG. PELDAÑO RECTO INT. ANTISLIP
120 x 33 x 45/3 (G 46 x 2) 48" x 13" x 17,7 1/16"
150 x 33 x 45/3 (G 51 x 2) 60" x 13" x 17,7 1/16"

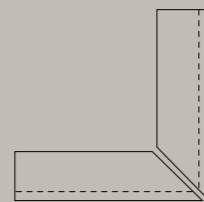

ÁNG. PELDAÑO RECTO EXT.
ÁNG. PELDAÑO RECTO EXT. ANTISLIP
120 x 33 x 45/3 (G 46 x 2) 48" x 13" x 17,7 1/16"
150 x 33 x 45/3 (G 51 x 2) 60" x 13" x 17,7 1/16"

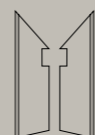

ZANQUÍN RCT. - IZQ. / DRCH.
9,8 x 30 (G 13) 4" x 11,8"



ÁNG. PELDAÑO RECTO
ÁNG. PELDAÑO RECTO ANTISLIP
33 x 45/3 (G 18 x 2PZ)
13" x 17,7 1/16"

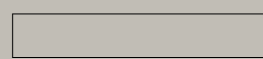

FRONTAL
15 x 120 (G 36) 6" x 48"



REMATE PELDAÑO
RECTO - IZQ. / DRCH.
3 x 33 (G 15) 1" x 13"

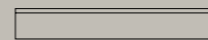

ZÓCALO
9,8 x 75 (G 17) 4" x 30"

BOTANICA

PORCELÁNICO RECTIFICADO
RECTIFIED PORCELAIN TILE

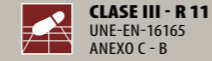

Pav. / Floor: Botánica Grey Antislip 25x150 - Peldaño Angular Botánica Grey Antislip 120x32/3 - Frontal Botánica Grey 15x120



Pav. / Floor: Botánica Alamo 25x150 - Peldaño Angular Botánica Alamo 120x32/3 - Frontal Botánica Alamo 15x120 - Zócalo Botánica Alamo 9,8x120 - Zanquín Angular Izq. / Drch. Botánica Alamo 9,8x30

* 18

25 x 150 (G 79)
25 x 150 (G 80) ANTISLIP
10" x 60"
x 10 mm.

* **CLASE I - R 9**
UNE-EN-16165
ANEXO C - B

* Colores ABEDUL y MAPLE solo disponibles en CLASE I - R9
* ABEDUL & MAPLE colors only available in CLASE I - R9

EXTRUSIONADO PORCELÁNICO
EXTRUDED PORCELAIN TILE

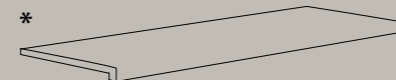

PELDAÑO ANGULAR
PELDAÑO ANGULAR ANTISLIP
120 x 32/3 (G 72) 48" x 12,5"/1" ♦
60 x 32/3 (G 73) 23,6" x 12,5"/1" ♦

REMATE PELDAÑO
ANGULAR · IZQ. / DRCH.
3 x 32 (G 15) 1" x 12,5" ♦



FRONTAL
15 x 120 (G 74) 6" x 48" ♦

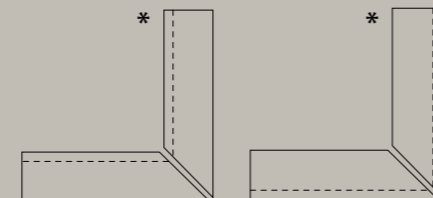

ÁNG. PELDAÑO ANG. INT.
ÁNG. PELDAÑO ANG. INT.
ANTISLIP
120 x 32 x 45/3 (G 46 x 2)
48" x 12,5" x 17,7"/1" ♦

ÁNG. PELDAÑO ANG. EXT.
ÁNG. PELDAÑO ANG. EXT.
ANTISLIP
120 x 32 x 45/3 (G 46 x 2)
48" x 12,5" x 17,7"/1" ♦



ÁNG. PELDAÑO ANG.
ÁNG. PELDAÑO ANG. ANTISLIP
32 x 45/3 (G 18 x 2PZ)
12,5" x 17,7"/1" ♦



ZÓCALO
9,8 x 75 (G 74) 3,9" x 30" ♦

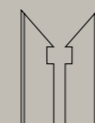

ZANQUÍN ANG. · IZQ. / DRCH.
9,8 x 30 (G 12) 4" x 11,8" ♦



BOTANICA GREY
BOTANICA GREY ANTISLIP



BOTANICA ALAMO
BOTANICA ALAMO ANTISLIP



BOTANICA ABEDUL



BOTANICA MAPLE

NATURA 25x150

PORCELÁNICO RECTIFICADO
RECTIFIED PORCELAIN TILE

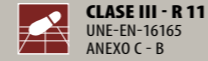

Pav. / Floor: Natura Sand 25x150 - Peldaño Angular Natura Sand 120x32/3 - Frontal Natura Sand 15x120



Pav. / Floor: Natura Camel 25x150
Rev. / Wall: Lineage Ivory 6,5x20

18

25 x 150 (G 79)
25 x 150 (G 80) ANTISLIP
10" x 60" mm
± 10 mm.

EXTRUSIONADO PORCELÁNICO
EXTRUDED PORCELAIN TILE

PIEZAS ESPECIALES · SPECIAL PIECES

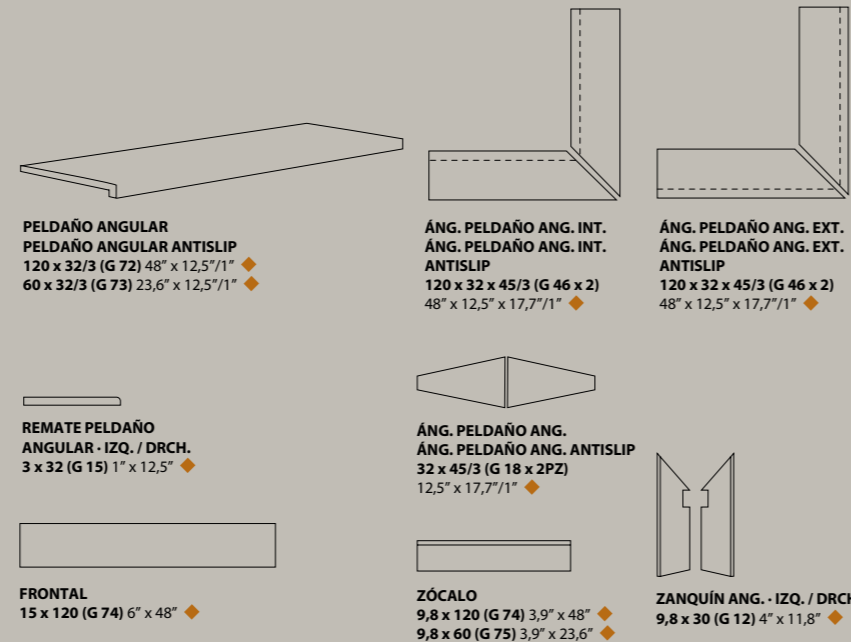

NATURA SAND
NATURA SAND ANTISLIP



NATURA CAMEL
NATURA CAMEL ANTISLIP

NATURA

PORCELÁNICO RECTIFICADO
RECTIFIED PORCELAIN TILE

CLASE I - R 9
UNE-EN-16165
ANEXO C - B

CLASE III - R 11
UNE-EN-16165
ANEXO C - B

CLASS B
UNE-EN-16165
ANEXO A

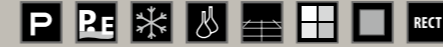

Pav. / Floor: Natura Sand 20x120 - Peldaño Angular Natura Sand 120x32/3 - Remate Peldaño Angular Izq. / Drch. Natura Sand 3x32 - Frontal Natura Sand 15x120



Pav. / Floor: Natura Camel 20x120 - Peldaño Angular Natura Camel 120x32/3 - Remate Peldaño Angular Izq. / Drch. Natura Camel 3x32



Pav. / Floor: Natura Umber 20x120 - Peldaño Angular Natura Umber 60x32/3 - Zanquín Angular Natura Umber 9,8x30 - Zócalo Natura Umber 9,8x60

* **20 x 120 (G 68)**
20 x 120 (G 70) ANTISLIP
8" x 48" **18**
9 mm.

* **CLASE I - R 9**
UNE-EN-16165
ANEXO C - B

* Colores UMBER y WHITE solo disponibles en CLASE I - R 9
* UMBER & WHITE colors only available in CLASE I - R 9

ESPECIFICACIONES TÉCNICAS - TECHNICAL SPECIFICATIONS

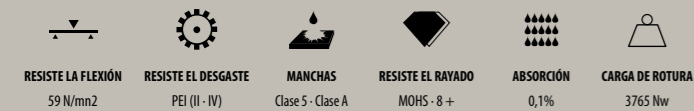

EXTRUSIONADO PORCELÁNICO
EXTRUDED PORCELAIN TILE

PIEZAS ESPECIALES - SPECIAL PIECES

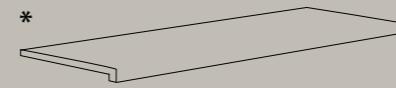

* **PELDAÑO ANGULAR**
PELDAÑO ANGULAR ANTISLIP
120 x 32/3 (G 72) 48" x 12,5"/1"
60 x 32/3 (G 73) 23,6" x 12,5"/1"

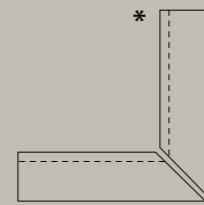

* **ÁNG. PELDAÑO ANG. INT.**
ÁNG. PELDAÑO ANG. INT.
ANTISLIP
120 x 32 x 45/3 (G 46 x 2)
48" x 12,5" x 17,7"/1"

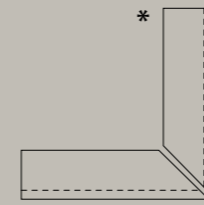

* **ÁNG. PELDAÑO ANG. EXT.**
ÁNG. PELDAÑO ANG. EXT.
ANTISLIP
120 x 32 x 45/3 (G 46 x 2)
48" x 12,5" x 17,7"/1"



* **ÁNG. PELDAÑO ANG.**
ÁNG. PELDAÑO ANG. ANTISLIP
32 x 45/3 (G 18 x 2PZ)
12,5" x 17,7"/1"

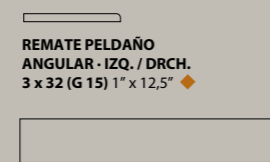

* **REMATE PELDAÑO**
ANGULAR - IZQ. / DRCH.
3 x 32 (G 15) 1" x 12,5"

* **FRONTAL**
15 x 120 (G 74) 6" x 48"



* **ZÓCALO**
9,8 x 120 (G 74) 3,9" x 48"
9,8 x 60 (G 75) 3,9" x 23,6"

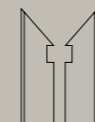

* **ZANQUÍN ANG. - IZQ. / DRCH.**
9,8 x 30 (G 12) 4" x 11,8"



NATURA SAND



NATURA CAMEL
NATURA CAMEL ANTISLIP

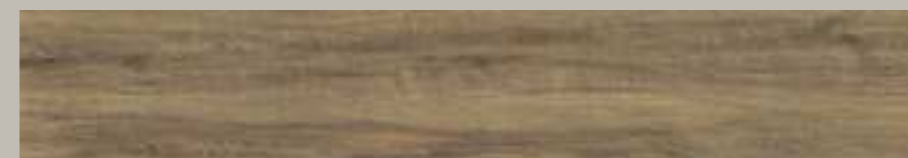

NATURA UMBER



NATURA WHITE
NATURA WHITE ANTISLIP



Pav. / Floor: Alquézar Arena 20x120 · Alquézar Arena Antislip 20x120 · Peldaño Angular Alquézar Arena Antislip 120x32/3 · Frontal Alquézar Arena 15x120 · Zócalo Alquézar Arena 9,8x60



Pav. / Floor: Alquézar Miel 20x120 · Peldaño Angular Alquézar Miel 120x32/3 · Remate Peldaño Angular Izq. Alquézar Miel 3x32 Frontal Alquézar Miel 15x120 · Zanquín Angular Alquézar Miel 9,8x30 · Zócalo Alquézar Miel 9,8x60

* **20 x 120 (G 68)**
20 x 120 (G 70) ANTISLIP
8" x 48" **9**
9 mm.

* **CLASE I - R 9**
UNE-EN-16165
ANEXO C - B
* Color MIEL solo disponibles en CLASE I - R9
* MIEL colors only available in CLASE I - R9

ESPECIFICACIONES TÉCNICAS · TECHNICAL SPECIFICATIONS

| | | | | | |
|--------------------------------|--------------------------------------|------------------------------|-------------------------------|-------------------|----------------------------|
| | | | | | |
| RESISTE LA FLEXIÓN 59 N/mn2 | RESISTE EL DESGASTE PEI (II - IV) | MANCHAS Clase 5 - Clase A | RESISTE EL RAYADO MOHS - 7 | ABSORCIÓN 0,1% | CARGA DE ROTURA 3765 Nw |

EXTRUSIONADO PORCELÁNICO · EXTRUDED PORCELAIN TILE



*

PELDAÑO ANGULAR
PELDAÑO ANGULAR ANTISLIP
120 x 32/3 (G 72) 48" x 12,5"/1"
60 x 32/3 (G 73) 23,6" x 12,5"/1"

*

ÁNG. PELDAÑO ANG. INT.
ÁNG. PELDAÑO ANG. INT. ANTISLIP
120 x 32 x 45/3 (G 46 x 2)
48" x 12,5" x 17,7"/1"

*

ÁNG. PELDAÑO ANG. EXT.
ÁNG. PELDAÑO ANG. EXT. ANTISLIP
120 x 32 x 45/3 (G 46 x 2)
48" x 12,5" x 17,7"/1"

*

REMATE PELDAÑO ANGULAR - IZQ. / DRCH.
3 x 32 (G 15) 1" x 12,5"

*

ÁNG. PELDAÑO ANG. ANTISLIP
32 x 45/3 (G 18 x 2PZ)
12,5" x 17,7"/1"

*

FRONTAL
15 x 120 (G 74) 6" x 48"

*

ZÓCALO
9,8 x 120 (G 74) 3,9" x 48"
9,8 x 60 (G 75) 3,9" x 23,6"

*

ZANQUÍN ANG. - IZQ. / DRCH.
9,8 x 30 (G 12) 4" x 11,8"



ALQUÉZAR TABACO
ALQUÉZAR TABACO ANTISLIP



ALQUÉZAR MIEL



ALQUÉZAR ARENA
ALQUÉZAR ARENA ANTISLIP



Pav. / Floor: Stanley Park 20x120 · Peldaño Angular Stanley Park 120x32/3 · Frontal Stanley Park 15x120



Rev. / Wall: Hyde Park 20x120 · Convex Calç 5x25
Pav. / Floor: Hyde Park 20x120



Pav. / Floor: Retiro Park 20x120

20 x 120 (G 68)
20 x 120 (G 70) ANTISLIP
8" x 48"
9 mm.

18

* **CLASE I - R 9**
UNE-EN-16165
ANEXO C - B

* Colores RETIRO PARK y STANLEY PARK solo disponibles en CLASE I - R9
* RETIRO PARK & STANLEY PARK colors only available in CLASE I - R9

ESPECIFICACIONES TÉCNICAS · TECHNICAL SPECIFICATIONS

| | | | | | |
|--|--------------------------------------|------------------------------|-----------------------------|-------------------|----------------------------|
| | | | | | |
| RESISTE LA FLEXIÓN 59 N/mm ² | RESISTE EL DESGASTE PEI (II - IV) | MANCHAS Clase 5 - Clase A | RESISTE EL RAYADO MOHS-7 | ABSORCIÓN 0,1% | CARGA DE ROTURA 3765 Nw |

EXTRUSIONADO PORCELÁNICO
EXTRUDED PORCELAIN TILE

PIEZAS ESPECIALES · SPECIAL PIECES

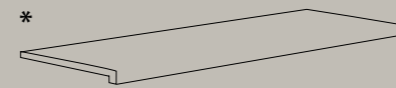

* **PELDAÑO ANGULAR**
PELDAÑO ANGULAR ANTISLIP
120 x 32/3 (G 72) 48" x 12,5"/1"
60 x 32/3 (G 73) 23,6" x 12,5"/1"

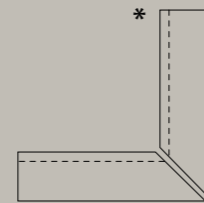

* **ÁNG. PELDAÑO ANG. INT.**
ÁNG. PELDAÑO ANG. INT.
ANTISLIP
120 x 32 x 45/3 (G 46 x 2)
48" x 12,5" x 17,7"/1"

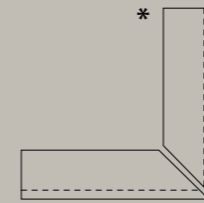

* **ÁNG. PELDAÑO ANG. EXT.**
ÁNG. PELDAÑO ANG. EXT.
ANTISLIP
120 x 32 x 45/3 (G 46 x 2)
48" x 12,5" x 17,7"/1"

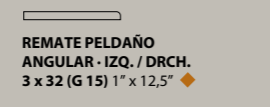

* **REMATE PELDAÑO**
ANGULAR · IZQ. / DRCH.
3 x 32 (G 15) 1" x 12,5"

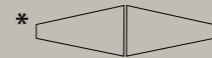

* **ÁNG. PELDAÑO ANG.**
ÁNG. PELDAÑO ANG. ANTISLIP
32 x 45/3 (G 18 x 2PZ)
12,5" x 17,7"/1"

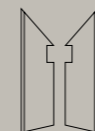

* **ZÓCALO**
9,8 x 120 (G 74) 3,9" x 48"
9,8 x 60 (G 75) 3,9" x 23,6"

* **FRONTAL**
15 x 120 (G 74) 6" x 48"

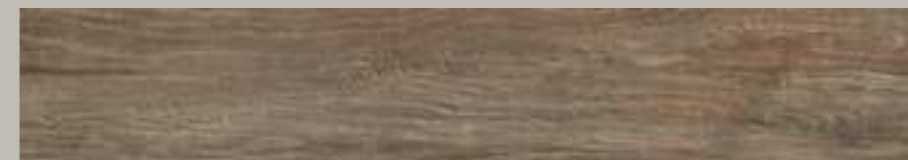

RETIRO PARK



HYDE PARK
HYDE PARK ANTISLIP



STANLEY PARK



CENTRAL PARK
CENTRAL PARK ANTISLIP

RETRO

EXTRUSIONADO PORCELÁNICO
EXTRUDED PORCELAIN TILE

CLASE III - R 11
UNE-EN-16165
ANEXO C - B



Pav. / Floor: **Retro Blanc Antislip 21x60** · **Retro Blanc Antislip 7x60**
Peldaño Angular Retro Blanc Antislip 32x32/4



Rev. / Wall: **Retro Blanc Antislip 7x60**
Pav. / Floor: **Retro Blanc Hex Antislip 36x41,5**



Pav. / Floor: **Retro Negro Antislip 21x60**



RETRO BLANC ANTISLIP



RETRO NEGRO ANTISLIP



7 x 60 (G 27) ANTISLIP
3" x 23,6" m^2
x 10 mm.

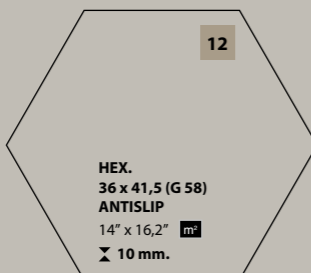

HEX. 36 x 41,5 (G 58) ANTISLIP
14" x 16,2" m^2
x 10 mm.



21 x 60 (G 38) ANTISLIP
8" x 23,6" m^2
x 10 mm.

ESPECIFICACIONES TÉCNICAS · TECHNICAL SPECIFICATIONS



PIEZAS ESPECIALES · SPECIAL PIECES



PELDAÑO ANGULAR ANTISLIP
32 x 32/4 (G 17) 12,5" x 12,5"/1,5" ◆



ÁNG. PELDAÑO ANG. ANTISLIP
32 x 45/4 (G 18 x 2PZ) 12,5" x 17,7"/1,5" ◆



ZÓCALO
9 x 30 (G 06) 3,5" x 11,8" ◆

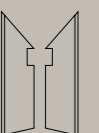

ZANQUÍN ANG. · IZQ. / DCHA.
9 x 30 (G 10) 3,5" x 11,8" ◆



Project Zero



COLECCIONES · COLLECTIONS

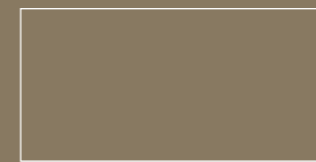

ARTIES 162 - 169
SAONA 170 - 175



CERLER 176 - 181
TOSCANA 182 - 187

NATUCER
cerámica natural



Arties Mix Antislip 30,3 x 61,3



ARTIES, esencia de piedra reinterpretada.
ARTIES, the essence of stone reinterpreted.

ARTIES
30,3 x 61,3



NATUCER
cerámica natural

NEW
2026

ARTIES

ARTIES es una colección que reinterpreta la esencia de la piedra desde una mirada contemporánea. Sus superficies evocan la solidez, la textura y la naturalidad de la materia original, trasladando al diseño cerámico un lenguaje auténtico y atemporal.

ARTIES is a collection that reinterprets the essence of stone from a contemporary perspective. Its surfaces evoke the solidity, texture, and natural character of the original material, bringing an authentic and timeless language to ceramic design.

NATUCER
cerámica natural



Rev. / Wall: Arties Mix Antislip 30,3x61,3
Pav. / Floor: Natur-Tech Central Park Antislip 20x90/2,6



Pav. / Floor: Arties Vulcano Antislip 30,3x61,3 · Peldaño Block Arties Vulcano Antislip 120x33/1,4



Pav. / Floor: Arties Mix Antislip 30,3x61,3 · Peldaño Recto Arties Mix Con Goterón Antislip 61,3x32/3 · Borde Piscina Arties Mix Antislip 61,3x45/3 · Esq. Borde Piscina Int. Arties Mix Antislip 61,3x45x63/3



ARTIES VULCANO ANTISLIP



ARTIES IVORY ANTISLIP



ARTIES MIX ANTISLIP



ARTIES WHITE ANTISLIP



ARTIES BEIGE ANTISLIP



ARTIES BALI ANTISLIP



Pav. / Floor: Arties White Antislip 30,3x61,3 · Peldaño Block White Antislip 120x33/1,4
Vaso Piscina / Pool Basin: Relieve Arties Mix Antislip 30,3x61,3 · Peldaño Block Mix Antislip 120x33/1,4



Pav. / Floor: Arties Ivory Antislip 30,3x61,3 · Peldaño Recto Arties Ivory Con Goterón Antislip 61,3x32/3 · Desbordante Arties Ivory Antislip 50x30,5/2,4
Esq.Desbordante Int. Arties Ivory Antislip 50x30,5/2,4 · Grating Arties Ivory Antislip 50x25/2,2 · Ang. Grating Arties Ivory Antislip 50x25/2,2
Vaso Piscina / Pool Basin: Relieve Arties Bali Antislip 30,3x61,3 · Peldaño Block Bali Antislip 120x33/1,4



RELIEVE ARTIES MIX ANTISLIP
30,3 x 61,3 (G 36) 11,9" x 24,1" **m**
x 10 mm.



RELIEVE ARTIES BALI ANTISLIP
30,3 x 61,3 (G 36) 11,9" x 24,1" **m**
x 10 mm.

⊖ Escala reducida - Reduced scale



⊖ Escala reducida - Reduced scale



EXTRUSIONADO PORCELÁNICO
EXTRUDED PORCELAIN TILE



PIEZAS ESPECIALES · SPECIAL PIECES

Disponible en todos los colores - Available in all colors



PELDAÑO BLOCK ANTISLIP
120 x 33/1,4 (G 79) 48" x 13"/0,5" **◆**



PELDAÑO RECTO CON GOTERÓN ANTISLIP
61,3 x 32/3 (G 80) 24" x 12,5"/1" **◆**

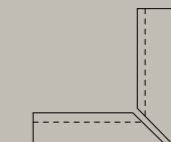

ÁNG. PELDAÑO RECTO INT. ANTISLIP
61,3 x 32 x 46/3 (G 56 x 2)
24" x 12,5" x 18"/1" **◆**

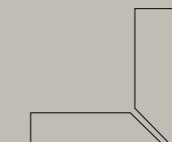

ÁNG. PELDAÑO RECTO EXT. ANTISLIP
61,3 x 32 x 46/3 (G 56 x 2)
24" x 12,5" x 18"/1" **◆**

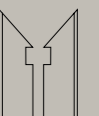

ZANQUÍN RECTO - IZQ. / DRCHA.
9 x 30,3 (G 10) 3,5" x 11,9" **◆**



CUBRECANTO
4 x 30/4 (G 13) 1,5" x 11,8"/1,5" **◆**



COMP. EXT. CUBRECANTO
4 x 4 (G 17) 1,5" x 1,5" **◆**



COMP. INT. CUBRECANTO
4 x 4 (G 17) 1,5" x 1,5" **◆**

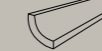

MEDIA CAÑA INT.
4 x 30/4 (G 12) 1,5" x 11,8"/1,5" **◆**



COMP. INT. MEDIA CAÑA
4 x 4 (G 17) 1,5" x 1,5" **◆**



COMP. EXT. MEDIA CAÑA
4 x 4 (G 17) 1,5" x 1,5" **◆**

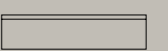

ZÓCALO
9 x 30,3 (G 06) 3,5" x 11,9" **◆**

EXTRUSIONADO PORCELÁNICO
EXTRUDED PORCELAIN TILE



PIEZAS ESPECIALES · SPECIAL PIECES

Disponible en WHITE, BEIGE, MIX y BALI - Available in WHITE, BEIGE, MIX & BALI



BORDE PISCINA ANTISLIP
61,3 x 28/4 (G 80)
24" x 11"/1,5" **◆**



ESQ. INT. BORDE PISCINA ANTISLIP
61,3 x 28 x 43,5/4 (G 56 x 2PZ)
24" x 11" x 17"/1,5" **◆**



ESQ. EXT. BORDE PISCINA ANTISLIP
61,3 x 28 x 43,5/4 (G 56 x 2PZ)
24" x 11" x 17"/1,5" **◆**

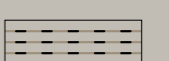

GRATING ANTISLIP
50 x 25/2,2 (G 78) 20" x 10"/1" **◆**



DESBORDANTE ANTISLIP
50 x 30,5/2,4 (G 80)
20" x 12"/1" **◆**



ESQ. INT. DESBORDANTE ANTISLIP
50 x 30,5 x 40/2,4 (G 56 x 2PZ)
20" x 12" x 16"/1" **◆**

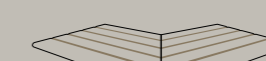

ESQ. EXT. DESBORDANTE ANTISLIP
50 x 30,5 x 40/2,4 (G 56 x 2PZ)
20" x 12" x 16"/1" **◆**



ÁNGULO GRATING ANTISLIP
25 x 50 x 35/2,2 (G 60 x 2PZ)
10" x 20" x 14"/1" **◆**



Saona Beige Antislip 30,3 x 61,3

SAONA, equilibrio entre luz, agua y piedra.
SAONA, balance between light, water, and stone.

SAONA
30,3 x 61,3



NATUCER
cerámica natural

NEW
2026

SAONA

SAONA es una colección donde sus superficies evocan la serenidad del paisaje mediterráneo, con texturas suaves y matices que recuerdan la piedra erosionada por el mar y la calidez de la luz costera, pensadas para integrarse con naturalidad en espacios que valoran la autenticidad, la calma y la materia como protagonista.

SAONA is a collection whose surfaces evoke the serenity of the Mediterranean landscape, with soft textures and nuances that recall stone shaped by the sea and the warmth of coastal light, designed to blend naturally into spaces that value authenticity, calm, and material as the central element.

NATUCER
cerámica natural



Pav. / Floor: Saona Beige Antislip 30,3x61,3 • Peldaño Block Saona Beige 120x33/1,4 • Borde Piscina Saona Beige 61,3x28/4



Pav. / Floor: Saona White Antislip 30,3x61,3 - Peldaño Block Saona White Antislip 120x33/1,4 - Borde Piscina Saona White Antislip 61,3x28/4 - Esq. Borde Piscina Int. Saona White Antislip 61,3x28 x 43,5/4



Pav. / Floor: Saona Grey Antislip 30,3x61,3 - Peldaño Recto Con Goterón Saona Grey Antislip 61,3x32/3 - Zócalo Saona Grey 9x30,3 - Zanquín Recto Saona Grey 9x30,3 - Ángulo Peldaño Recto Ext. Saona Grey Antislip 61,3x32x46/3

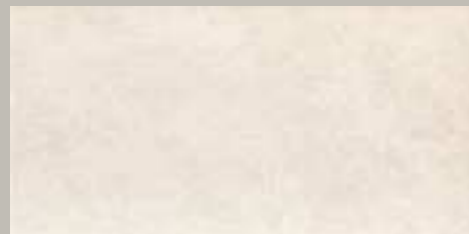

SAONA WHITE ANTISLIP
30,3 x 61,3 (G 36) 12" x 24" **m**
± 9 mm.

24



SAONA BEIGE ANTISLIP
30,3 x 61,3 (G 36) 12" x 24" **m**
± 9 mm.

24



SAONA GREY ANTISLIP
30,3 x 61,3 (G 36) 12" x 24" **m**
± 9 mm.

24

EXTRUSIONADO PORCELÁNICO
EXTRUDED PORCELAIN TILE

PIEZAS ESPECIALES - SPECIAL PIECES



PELDAÑO BLOCK ANTISLIP
120 x 33/1,4 (G 79) 48" x 13"/0,5" ◆



PELDAÑO RECTO CON GOTERÓN ANTISLIP
61,3 x 32/3 (G 80) 24" x 12,5"/1" ◆

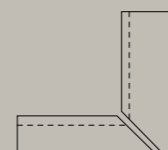

ÁNG. PELDAÑO RECTO INT. ANTISLIP
61,3 x 32 x 46/3 (G 56 x 2)
24" x 12,5" x 18"/1" ◆

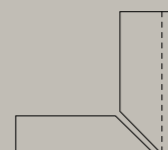

ÁNG. PELDAÑO RECTO EXT. ANTISLIP
61,3 x 32 x 46/3 (G 56 x 2)
24" x 12,5" x 18"/1" ◆



ZANQUÍN RECTO - IZQ. / DRCHA.
9 x 30,3 (G 10) 3,5" x 11,9" ◆



CUBRECANTO
4 x 30/4 (G 13) 1,5" x 11,8"/1,5" ◆



COMP. EXT. CUBRECANTO
4 x 4 (G 17) 1,5" x 1,5" ◆



COMP. INT. CUBRECANTO
4 x 4 (G 17) 1,5" x 1,5" ◆



MEDIA CAÑA INT.
4 x 30/4 (G 12) 1,5" x 11,8"/1,5" ◆



COMP. INT. MEDIA CAÑA
4 x 4 (G 17) 1,5" x 1,5" ◆



COMP. EXT. MEDIA CAÑA
4 x 4 (G 17) 1,5" x 1,5" ◆



ZÓCALO
9 x 30,3 (G 06) 3,5" x 11,9" ◆



BORDE PISCINA ANTISLIP
61,3 x 28/4 (G 80)
24" x 11"/1,5" ◆

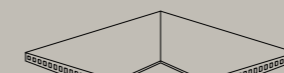

ESQ. INT. BORDE PISCINA ANTISLIP
61,3 x 28 x 43,5/4 (G 56 x 2PZ)
24" x 11" x 17"/1,5" ◆

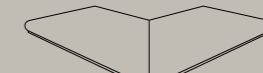

ESQ. EXT. BORDE PISCINA ANTISLIP
61,3 x 28 x 43,5/4 (G 56 x 2PZ)
24" x 11" x 17"/1,5" ◆

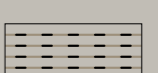

GRATTING ANTISLIP
50 x 25/2,2 (G 78) 20" x 10"/1" ◆

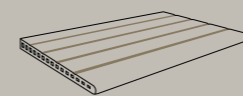

DESBORDANTE ANTISLIP
50 x 30,5/2,4 (G 80)
20" x 12"/1" ◆

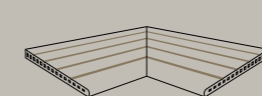

ESQ. INT. DESBORDANTE ANTISLIP
50 x 30,5 x 40/2,4 (G 56 x 2PZ)
20" x 12" x 16"/1" ◆

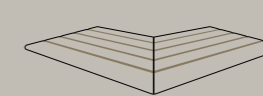

ESQ. EXT. DESBORDANTE ANTISLIP
50 x 30,5 x 40/2,4 (G 56 x 2PZ)
20" x 12" x 16"/1" ◆

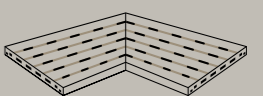

ÁNGULO GRATTING ANTISLIP
25 x 50 x 35/2,2 (G 60 x 2PZ)
10" x 20" x 14"/1" ◆

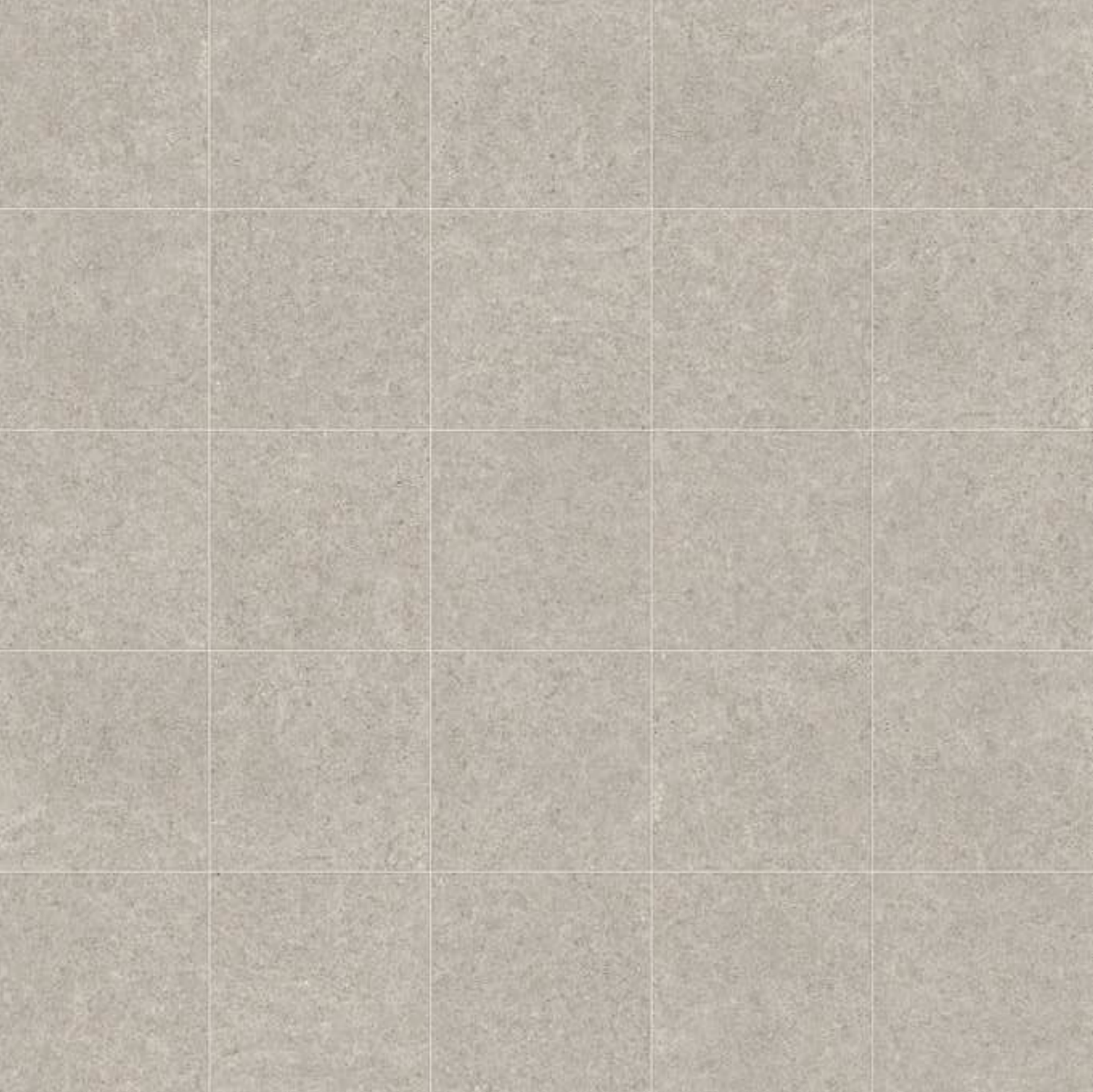

Cerler Greige Antislip 33,3 x 33,3



CERLER, la esencia de la alta montaña hecha materia.
CERLER, the essence of the high mountains made material.

CERLER
33,3 x 33,3

NATUCER
cerámica natural



NEW
2026

CERLER

CERLER es una colección inspirada en la alta montaña, donde nieve, roca y tradición se funden en un paisaje de pureza y calma.

Sus superficies evocan la fuerza de la piedra y la calidez de la madera.

CERLER is a collection inspired by the high mountains, where snow, rock, and tradition blend into a landscape of purity and calm.

Its surfaces evoke the strength of stone and the warmth of wood.

NATUCER
cerámica natural



Pav. / Floor: Cerler Greige Antislip 33,3x33,3
Rev. / Wall: Cerler Greige Antislip 33,3x33,3



Pav. / Floor: Cerler Greige Antislip 33,3x33,3 - Peldaño Recto Con Goterón Cerler Greige Antislip 33,3x33,3/3 - Vierteaguas Cerler Greige Antislip 15x33,3/4



Pav. / Floor: Cerler Ivory Antislip 33,3x33,3 - Pasamanos Cerler Ivory 1 Antislip 8x33,3/4
Rev. / Wall: Alquézar Arena 20x120

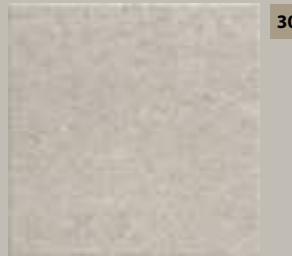

30

CERLER GREIGE ANTISLIP
33,3 x 33,3 (G 36) 13,1" x 13,1" **m²**
Σ 9 mm.



30

CERLER WHITE ANTISLIP
33,3 x 33,3 (G 36) 13,1" x 13,1" **m²**
Σ 9 mm.



30

CERLER IVORY ANTISLIP
33,3 x 33,3 (G 36) 13,1" x 13,1" **m²**
Σ 9 mm.

EXTRUSIONADO PORCELÁNICO
EXTRUDED PORCELAIN TILE

PIEZAS ESPECIALES · SPECIAL PIECES



PELDAÑO RECTO CON GOTERÓN ANTISLIP
33,3 x 33,3/3 (G 17) 13,1" x 12,6"/1" ◆



VIERTEAGUAS ANTISLIP
15 x 33,3/4 (G 12) 5,9" x 13,1"/1,5" ◆



PASAMANOS ANTISLIP
18 x 33,3/4 (G 30) 7" x 13,1"/1,5" ◆

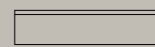

ZÓCALO
8 x 33,3 (G 06) 3" x 13,1" ◆



ZANQUÍN RECTO. · IZQ. / DRCHA.
8 x 33,3 (G 10) 3" x 13,1" ◆



Toscana Arena Antislip 33,3 x 33,3

TOSCANA, la elegancia sencilla de la arquitectura tradicional.
TOSCANA, the simple elegance of traditional architecture.

TOSCANA
33,3 x 33,3

NATUCER
cerámica natural



NEW
2026

TOSCANA

TOSCANA es una colección inspirada en la belleza serena del paisaje italiano, donde la piedra, la tierra y la arquitectura tradicional se combinan en una estética cálida y atemporal. Sus superficies evocan tonos naturales y texturas suaves que aportan equilibrio, elegancia y autenticidad, creando espacios con carácter propio y un marcado aire mediterráneo.

TOSCANA is a collection inspired by the serene beauty of the Italian landscape, where stone, earth, and traditional architecture come together in a warm and timeless aesthetic. Its surfaces evoke natural tones and soft textures that bring balance, elegance, and authenticity, creating spaces with a distinctive character and a strong Mediterranean feel.

NATUCER
cerámica natural



Pav. / Floor: Toscana Arena Antislip 33,3x33,3 - Pasamanos Toscana Arena Antislip 18x33,3/4 - Peldaño Curvo Toscana Arena Antislip 33,3x33,3/4 - Zócalo Toscana Arena 8x33,3



Pav. / Floor: Toscana Natural Antislip 33,3x33,3 - Pasamanos Toscana Natural Antislip 18x33,3/4 - Peldaño Curvo Toscana Natural Antislip 33,3x33,3/4 - Zócalo Toscana Natural 8x33,3 - Zanquín Curvo Toscana Natural 8x33,3



12

TOSCANA ARENA ANTISLIP
33,3 x 33,3 (G 36) 13,1" x 13,1" m²
± 9 mm.



12

TOSCANA NATURAL ANTISLIP
33,3 x 33,3 (G 36) 13,1" x 13,1" m²
± 9 mm.

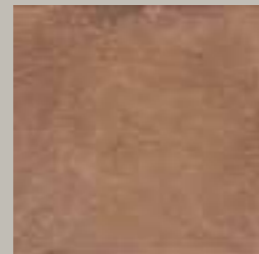

12

TOSCANA RÚSTICO ANTISLIP
33,3 x 33,3 (G 36) 13,1" x 13,1" m²
± 9 mm.

EXTRUSIONADO PORCELÁNICO
EXTRUDED PORCELAIN TILE

PIEZAS ESPECIALES - SPECIAL PIECES



PELDAÑO CURVO ANTISLIP
33,3 x 33,3/4 (G 17) 13,1" x 12,6"/1" ♦

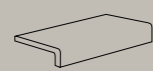

VIERTEAGUAS ANTISLIP
15 x 33,3/4 (G 12) 5,9" x 13,1"/1,5" ♦

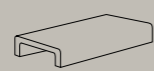

PASAMANOS ANTISLIP
18 x 33,3/4 (G 30) 7" x 13,1"/1,5" ♦

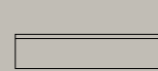

ZÓCALO
8 x 33,3 (G 06) 3" x 13,1" ♦

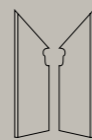

ZANQUÍN CURVO. - IZQ. / DRCHA.
8 x 33,3 (G 10) 3" x 13,1" ♦



Pav. / Floor: Toscana Rústico Antislip 33,3x33,3 - Pasamanos Toscana Rústico Antislip 18x33,3/4 - Peldaño Curvo Toscana Rústico Antislip 33,3x33,3/4 - Zócalo Toscana Rústico 8x33,3



COLECCIONES · COLLECTIONS

EXTRUSIONADO PORCELÁNICO EXTRUDED PORCELAIN TILE

| | |
|--------------|-----------|
| CAPRI | 207 |
| FRAME | 232 - 233 |
| MARE NOSTRUM | 238 - 239 |
| TABARCA | 228 - 231 |
| TEMPO | 234 - 237 |

PORCELÁNICO PORCELAIN TILE

| | |
|---------------|-----------|
| HERITAGE CLAY | 190 - 195 |
| LINEAGE | 208 - 213 |
| POOL | 224 - 225 |
| SARSEN STONE | 196 - 201 |

PASTA BLANCA WHITE BODY

| | |
|----------------|-----------|
| AUSTRAL | 218 |
| COOL | 204 - 205 |
| EVOKE | 216 - 217 |
| FIKA | 214 - 215 |
| HERITAGE CLAY | 190 - 195 |
| LIVERPOOL | 206 |
| PIASTRELLA MIX | 222 - 223 |
| STOW/STOW MIX | 226 - 227 |
| VEGA | 219 |
| WABI SABI | 202 - 203 |
| ZELLIGE | 220 - 221 |

Revestimiento

wall tile





Heritage Clay Emerald

Heritage Clay Emerald 6,5x20

Heritage Clay Emerald 15x15

HERITAGE CLAY: diversidad cromática con una identidad única.
HERITAGE CLAY: chromatic diversity with a unique identity.

HERITAGE CLAY



NATUCER
cerámica natural

NEW
2026

HERITAGE CLAY

HERITAGE CLAY es una colección de revestimiento cerámico que reinterpreta la belleza natural de la piedra con un enfoque actual. Sus piezas crean espacios dinámicos sin perder coherencia visual gracias a una textura continua que unifica toda la serie. Esta versatilidad permite jugar con composiciones y adaptarse a diferentes estilos y proyectos. Heritage Clay es la elección perfecta para quienes buscan un equilibrio entre diseño, calidez y una estética atemporal con carácter propio.

HERITAGE CLAY is a ceramic wall tile collection that reinterprets the natural beauty of stone with a contemporary approach. Its pieces create dynamic spaces while maintaining visual coherence thanks to a continuous texture that unifies the entire series. This versatility allows for creative compositions and adaptation to different styles and projects. Heritage Clay is the perfect choice for those seeking a balance between design, warmth, and a timeless aesthetic with its own character.

NATUCER
cerámica natural



Rev. / Wall: Heritage Clay Emerald 60x120 · Heritage Clay Emerald 6,5x20
Pav. / Floor: Sherwood Nut 25x150

HERITAGE CLAY

PORCELÁNICO
PORCELAIN TILE

NEW
2026

CLASE I - R 9
UNE-EN-16165
ANEXO C - B



Rev. / Wall: Heritage Clay Cotto 6,5x20 - Heritage Clay Cotto 30x60 - Heritage Clay Cotto 120x120
Pav. / Floor: Heritage Clay Cotto 30x60



Rev. / Wall: Heritage Clay Cotto 15x15 - Heritage Clay Greige 60x120
Pav. / Floor: Sherwood Nut 25x150



Rev. / Wall: Heritage Clay Ivory 6,5x20

9

6,5 x 20 (G 68)
2,5" x 8"
x 8 mm.

9

15 x 15 (G 68)
6" x 6"
x 8 mm.

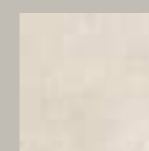

HERITAGE CLAY
WHITE



HERITAGE CLAY
IVORY

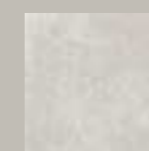

HERITAGE CLAY
PEARL



HERITAGE CLAY
GREIGE

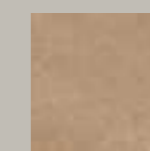

HERITAGE CLAY
COTTO



HERITAGE CLAY
BLUE



HERITAGE CLAY
EMERALD



Sarsen stone White 5x25

Sarsen stone White 15x15

SARSEN STONE, Pureza y frescura en equilibrio.
SARSEN STONE: Purity and freshness in balance.

SARSEN STONE



NATUCER
cerámica natural

NEW
2026

SARSEN STONE

SARSEN STONE, presenta dos tonalidades cuidadosamente seleccionadas: un blanco luminoso y un turquoise Bali lleno de frescura. La combinación de ambos colores permite crear espacios equilibrados y llenos de personalidad, donde la claridad y la vitalidad conviven en armonía. Su textura, fiel al carácter natural del material, aporta profundidad y autenticidad, convirtiendo cada superficie en un elemento protagonista.

SARSEN STONE presents two carefully selected tones: a luminous white and a fresh Bali turquoise. The combination of both colors allows for the creation of balanced, characterful spaces, where clarity and vitality coexist in harmony. Its texture, faithful to the natural character of the material, adds depth and authenticity, turning every surface into a focal element.

NATUCER
cerámica natural



Rev. / Wall: Sarsen Stone White 5x25 · Sarsen Stone White 15x15 · Luxor Clay 8x39x4
Pav. / Floor: Sherwood Linde 25x150

SARSEN STONE

PORCELÁNICO
PORCELAIN TILE

NEW
2026

CLASE I - R 9
UNE-EN-16165
ANEXO C - B



Rev. / Wall: Sarsen Stone White 5x25 - Sarsen Stone White 120x120
Pav. / Floor: Sarsen Stone White 120x120

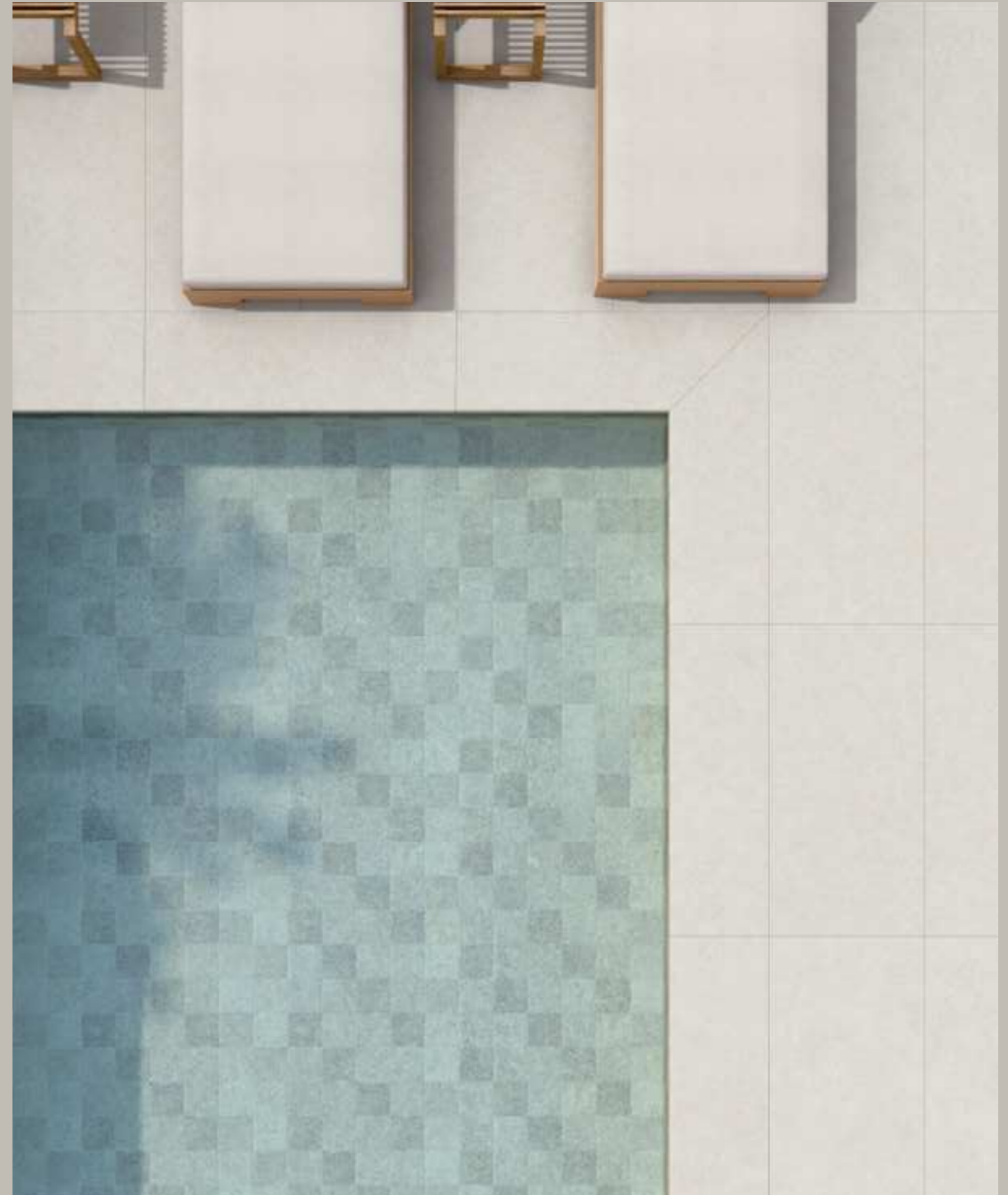

Pav. / Floor: Sarsen Stone White Antislip 60x120 · Peldaño Recto Sarsen Stone White Antislip 120x32/3 · Ángulo Peldaño Recto Int. Sarsen Stone White Antislip 120x32x45/3
Vaso Piscina / Pool Basin: Sarsen Stone Turquoise Bali 15x15

* Solo disponible en WHITE
* Only available in WHITE

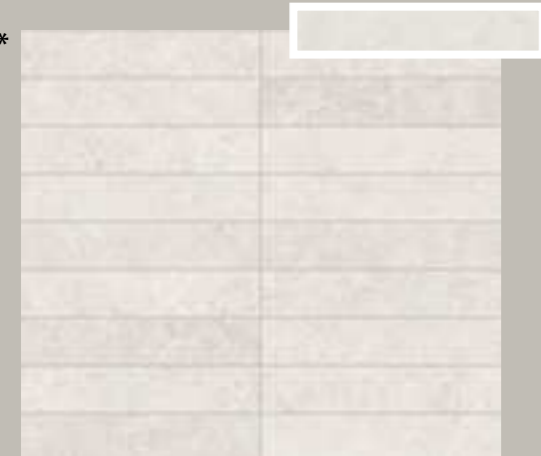

SARSEN STONE WHITE
5 x 25 (G 68) 2" x 10" m²
x 8 mm. **6**



SARSEN STONE WHITE
15 x 15 (G 68) 6" x 6" m²
x 8 mm. **6**



SARSEN STONE TURQUOISE BALI
15 x 15 (G 68) 6" x 6" m²
x 8 mm. **6**

WABI SABI

Pasta Blanca
WHITE BODY



MATE
MATT



BRILLO
GLOSS



Rev. / Wall: **Wabi Sabi Clear Matt 7x40**



Rev. / Wall: **Wabi Sabi White 7x40**



Rev. / Wall: **Wabi Sabi Aqua 7x40**



MATE
MATT



WABI SABI CLEAR MATT 7 x 40 (G 77) 3" x 16" m²
x 9 mm.



WABI SABI GRAY MATT 7 x 40 (G 77) 3" x 16" m²
x 9 mm.



BRILLO
GLOSS



WABI SABI WHITE 7 x 40 (G 77) 3" x 16" m²
x 9 mm.



WABI SABI AQUA 7 x 40 (G 77) 3" x 16" m²
x 9 mm.



SPECIAL ORDER
BAJO PEDIDO



WABI SABI NUDE MATT 7 x 40 (G 77) 3" x 16" m²
x 9 mm.



WABI SABI CLAY MATT 7 x 40 (G 77) 3" x 16" m²
x 9 mm.



WABI SABI DARK MATT 7 x 40 (G 77) 3" x 16" m²
x 9 mm.



WABI SABI ASH 7 x 40 (G 77) 3" x 16" m²
x 9 mm.



WABI SABI OLIVE 7 x 40 (G 77) 3" x 16" m²
x 9 mm.

PIEZAS ESPECIALES - SPECIAL PIECES

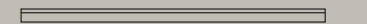

DEMI-BULLNOSE
1,5 x 30 (G 07) 0,6" x 11,8" ♦



Rev. / Wall: **Cool White 5x30**



Rev. / Wall: **Cool Ash 5x30**



Rev. / Wall: **Cool Emerald 5x30**



COOL WHITE 5 x 30 (G 77) 2" x 12" **m**
x 9 mm.



COOL ASH 5 x 30 (G 77) 2" x 12" **m**
x 9 mm.



COOL LATTE 5 x 30 (G 77) 2" x 12" **m**
x 9 mm.



COOL EMERALD 5 x 30 (G 77) 2" x 12" **m**
x 9 mm.



COOL NAVY 5 x 30 (G 77) 2" x 12" **m**
x 9 mm.

PIEZAS ESPECIALES - SPECIAL PIECES

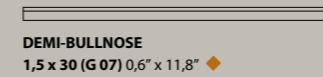

DEMI-BULLNOSE
1,5 x 30 (G 07) 0,6" x 11,8" ◆



Rev. / Wall: **Cool Navy 5x30**

LIVERPOOL

Pasta Blanca
WHITE BODY



Rev. / Wall: Liverpool White 5x30



LIVERPOOL WHITE 5 x 30 (G 77) 2" x 12" **m²**
x 9 mm.



LIVERPOOL GRAY 5 x 30 (G 77) 2" x 12" **m²**
x 9 mm.



LIVERPOOL NUDE 5 x 30 (G 77) 2" x 12" **m²**
x 9 mm.



LIVERPOOL KALE 5 x 30 (G 77) 2" x 12" **m²**
x 9 mm.

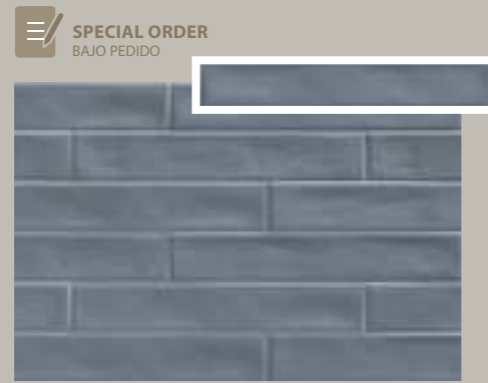

LIVERPOOL NAVY 5 x 30 (G 77) 2" x 12" **m²**
x 9 mm.



LIVERPOOL CLAY 5 x 30 (G 77) 2" x 12" **m²**
x 9 mm.

PIEZAS ESPECIALES - SPECIAL PIECES

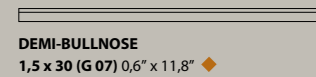

DEMI-BULLNOSE
1,5 x 30 (G 07) 0,6" x 11,8" ◆

CAPRI

EXTRUSIONADO PORCELÁNICO
EXTRUDED PORCELAIN TILE



Rev. / Wall: Capri Nieve 6,5x25

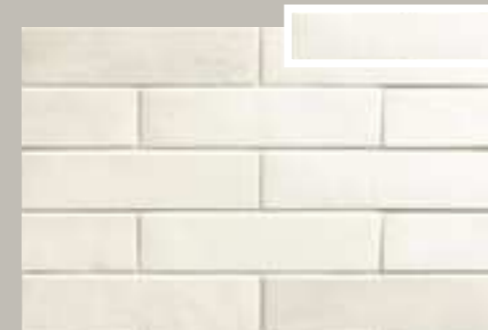

CAPRI NEVE 6,5 x 25 (G 56) 2,5" x 10" **m²**
x 11 mm.



CAPRI NERO 6,5 x 25 (G 56) 2,5" x 10" **m²**
x 11 mm.



CAPRI OLIVA 6,5 x 25 (G 56) 2,5" x 10" **m²**
x 11 mm.



CAPRI INDIGO 6,5 x 25 (G 56) 2,5" x 10" **m²**
x 11 mm.

PIEZAS ESPECIALES - SPECIAL PIECES

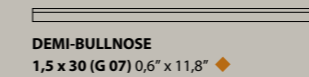

DEMI-BULLNOSE
1,5 x 30 (G 07) 0,6" x 11,8" ◆



Lineage Sage Green 6,5x20

LINEAGE, el brillo que define espacios con carácter.
LINEAGE, the shine that defines spaces with character.

LINEAGE



NATUCER
cerámica natural

NEW
2026

LINEAGE

LINEAGE es una colección de revestimiento cerámico en acabado brillante que aporta luminosidad y carácter a cualquier espacio. Permite múltiples composiciones, ofreciendo dinamismo y versatilidad en el diseño. Su superficie porcelánica refleja la luz y realza cada pieza, creando ambientes vibrantes, elegantes y llenos de personalidad. LINEAGE es la solución ideal para quienes buscan combinar funcionalidad, diseño y un acabado visualmente impactante.

LINEAGE is a glossy ceramic wall tile collection that brings luminosity and character to any space. It allows for multiple compositions, offering dynamism and versatility in design. Its porcelain surface reflects light and enhances each piece, creating vibrant, elegant, and personality-filled environments. LINEAGE is the ideal solution for those seeking to combine functionality, design, and a visually striking finish.

NATUCER
cerámica natural



Rev. / Wall: Lineage Sage Green 6,5x20 · Sarsen Stone Ivory 120x120
Pav. / Floor: Sarsen Stone Ivory Antislip 120x120



Rev. / Wall: **Lineage Ivory 6,5x20** - Demi-bullnose **Lineage Ivory 1,5x30**



Rev. / Wall: **Lineage Dark Coffee 6,5x20** - **Sarsen Stone Ivory 120x120**
Pav. / Floor: **Sarsen Stone Ivory 120x120**



Rev. / Wall: **Lineage Sage Green 6,5x20**



LINEAGE WHITE
6,5 x 20 (G 68) 2,5" x 8" **m²**
x 8 mm.



LINEAGE IVORY
6,5 x 20 (G 68) 2,5" x 8" **m²**
x 8 mm.



LINEAGE HONEY
6,5 x 20 (G 68) 2,5" x 8" **m²**
x 8 mm.



LINEAGE SAGE GREEN
6,5 x 20 (G 68) 2,5" x 8" **m²**
x 8 mm.



LINEAGE SKY BLUE
6,5 x 20 (G 68) 2,5" x 8" **m²**
x 8 mm.



LINEAGE IMPERIAL BLUE
6,5 x 20 (G 68) 2,5" x 8" **m²**
x 8 mm.



LINEAGE GRAPHITE
6,5 x 20 (G 68) 2,5" x 8" **m²**
x 8 mm.



LINEAGE DARK COFFEE
6,5 x 20 (G 68) 2,5" x 8" **m²**
x 8 mm.

PIEZAS ESPECIALES - SPECIAL PIECES



DEMI-BULLNOSE
1,5 x 30 (G 07) 0,6" x 11,8" ◆



Rev. / Wall: **Lineage Dark Coffee 6,5x20**

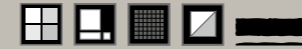

Rev. / Wall: **Fika Cotto 10x10**
Pav. / Floor: **Argile Palermo 45x45**



Rev. / Wall: **Fika Marsala 10x10**



Rev. / Wall: **Fika Bianco 10x10** - **Sarsen Stone Ivory 120x120**
Pav. / Floor: **Sarsen Stone Ivory 120x120**



FIKA OFF WHITE



FIKA COTTO

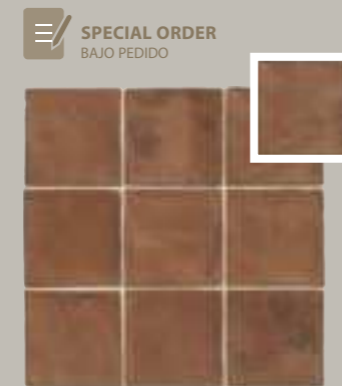

FIKA MARSALA



FIKA FOSSIL



FIKA BIANCO



FIKA SKY



FIKA KALE

SPECIAL ORDER
BAJO PEDIDO

PIEZAS ESPECIALES - SPECIAL PIECES

DEMI-BULLNOSE
1,5 x 30 (G 07) 0,6" x 11,8"

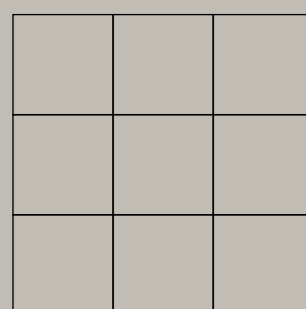

20
ENM. 30,5 x 30,5 (G 60)
12"x 12" m
9 mm.

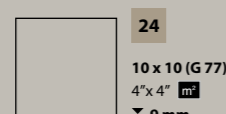

24
10 x 10 (G 77)
4"x 4" m
9 mm.



12
10 x 20 (G 77)
4"x 8" m
10 mm.



Solo disponible en SKY, BIANCO y OFF WHITE
Only available in SKY, BIANCO, and OFF WHITE



Rev. / Wall: **Fika Kale 10x10**



FIKA CLEAR 20 x 60 (G 27) 8"x 24"
10 mm.



FIKA BIANCO 20 x 60 (G 27) 8"x 24"
10 mm.

*

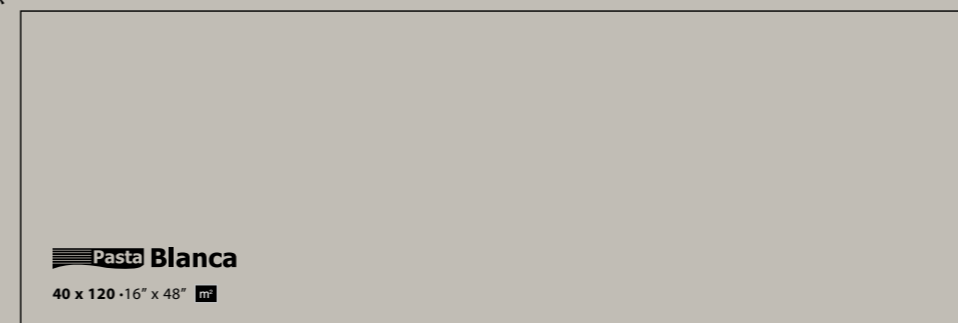

Pasta Blanca
40 x 120 - 16" x 48" m

* REVESTIMIENTO COORDINADO - COORDINATED WALL TILE

La serie FIKA combina con las bases de la series AUSTRAL pág. 218 y la serie VEGA pág. 219

The FIKA series is compatible with the bases from the AUSTRAL series page 218 and the VEGA series page 219



AUSTRAL (G 69)
Disponible en WHITE y BEIGE
Available in WHITE & BEIGE



VEGA (G 86)
Disponible en BIANCO
Available in BIANCO



Rev. / Wall: Evoke Lake 6,5x26 - Austral Bianco 40x120



Rev. / Wall: Evoke Kale 6,5x26



Rev. / Wall: Evoke Kale 6,5x26 - Sarsen Stone Greige 120x120
Pav. / Floor: Sarsen Stone Greige 120x120

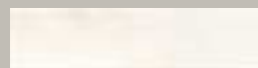

EVOKE CLEAR
6,5 x 26 (G 76) 2,5" x 10,2"
x 9 mm.



EVOKE LINEN
6,5 x 26 (G 76) 2,5" x 10,2"
x 9 mm.



EVOKE CLAY
6,5 x 26 (G 76) 2,5" x 10,2"
x 9 mm.



EVOKE KALE
6,5 x 26 (G 76) 2,5" x 10,2"
x 9 mm.



EVOKE LAKE
6,5 x 26 (G 76) 2,5" x 10,2"
x 9 mm.



SPECIAL ORDER
BAJO PEDIDO



EVOKE SKIN
6,5 x 26 (G 76) 2,5" x 10,2"
x 9 mm.



EVOKE CEMENT
6,5 x 26 (G 76) 2,5" x 10,2"
x 9 mm.



EVOKE DARK
6,5 x 26 (G 76) 2,5" x 10,2"
x 9 mm.

PIEZAS ESPECIALES · SPECIAL PIECES



PENCIL
2,5 x 30 (G 10) 1" x 11,8"



DEMI-BULLNOSE
1,5 x 30 (G 07) 0,6" x 11,8"

*

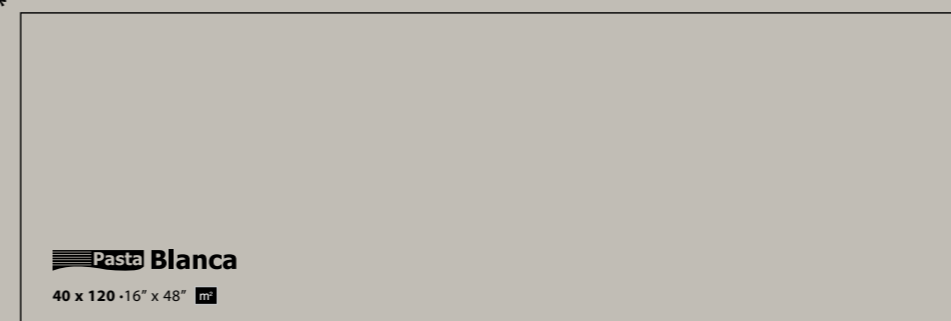

* REVESTIMIENTO COORDINADO - COORDINATED WALL TILE

La serie FIKA combina con las bases de la series AUSTRAL pág. 218 y la serie VEGA pág. 219

The FIKA series is compatible with the bases from the AUSTRAL series page 218 and the VEGA series page 219



AUSTRAL (G 69)
Disponible en WHITE y BEIGE
Available in WHITE & BEIGE



VEGA (G 86)
Disponible en BIANCO
Available in BIANCO

AUSTRAL

Pasta Blanca
WHITE BODY



Rev. / Wall: **Austral White 40x120**



Rev. / Wall: **Austral Beige 40x120**

VEGA

Pasta Blanca
WHITE BODY

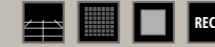

Rev. / Wall: **Vega Bianco 40x120**



Rev. / Wall: **Vega Bianco 40x120**

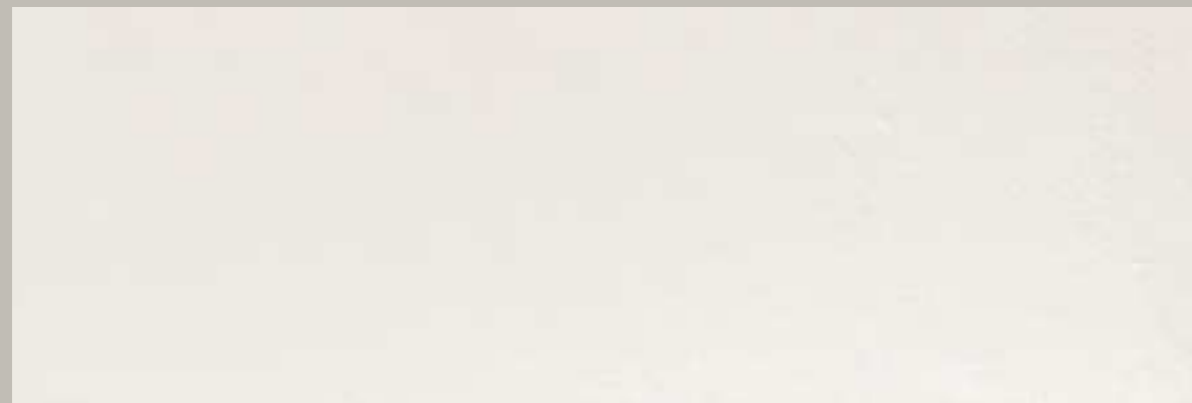

AUSTRAL WHITE 40 x 120 (G 69) 16" x 48" 
x 11 mm.

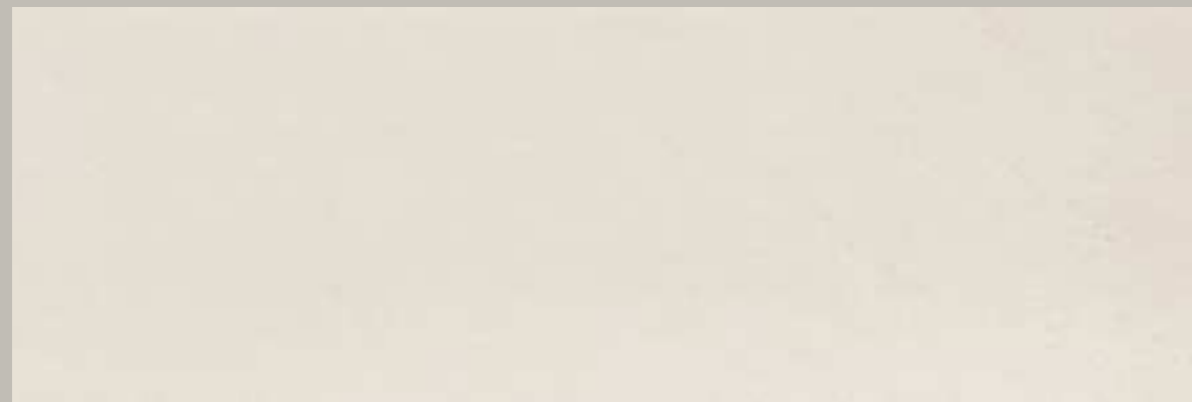

AUSTRAL BEIGE 40 x 120 (G 69) 16" x 48" 
x 11 mm.

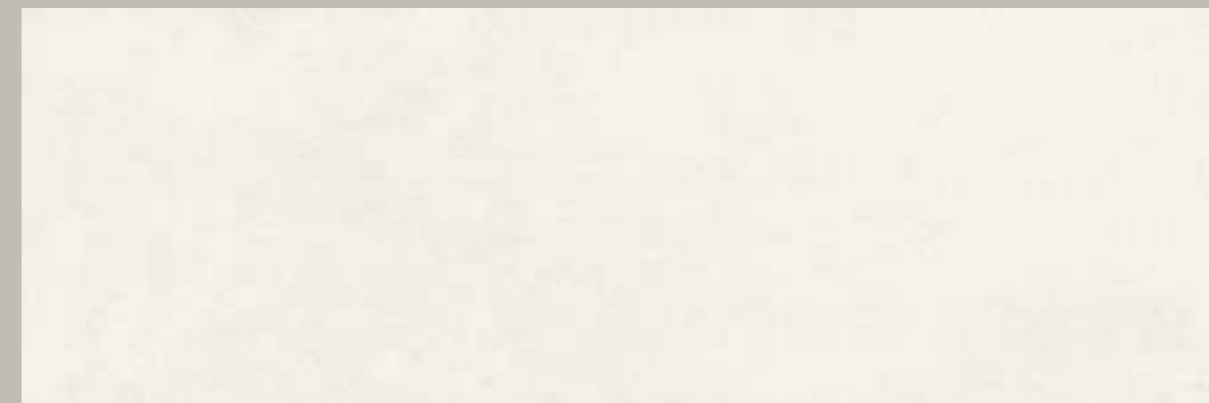

VEGA BIANCO 40 x 120 (G 86) 16" x 48" 
x 11 mm.

ZELLIGE

Pasta Blanca
WHITE BODY



Rev. / Wall: Zellige Grey 6,2x25



Rev. / Wall: Zellige White 6,2x25



Rev. / Wall: Zellige Green 6,2x25

BRILLO
GLOSS

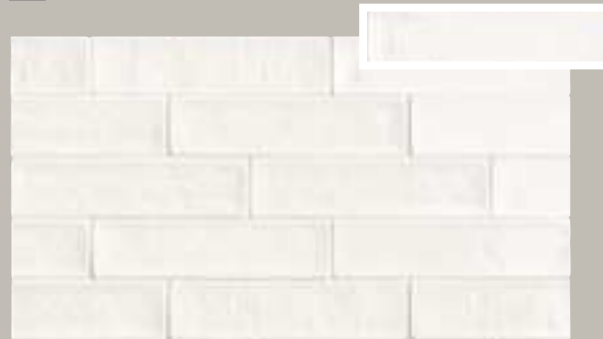

ZELLIGE WHITE 6,2 x 25 (G 27) 2,5" x 10" m²
x 9 mm.

BRILLO
GLOSS

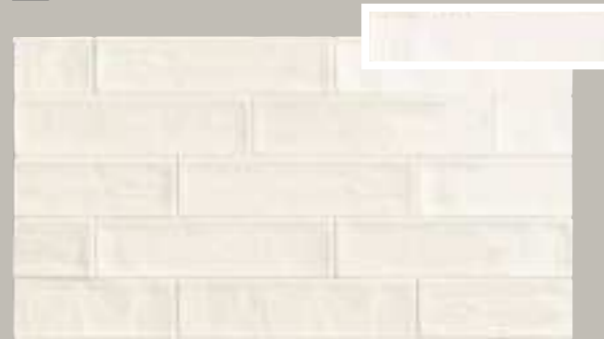

ZELLIGE BEIGE 6,2 x 25 (G 27) 2,5" x 10" m²
x 9 mm.



ZELLIGE BLUE 6,2 x 25 (G 27) 2,5" x 10" m²
x 9 mm.

SPECIAL ORDER
BAJO PEDIDO



ZELLIGE ROSE 6,2 x 25 (G 27) 2,5" x 10" m²
x 9 mm.

MATE
MATT

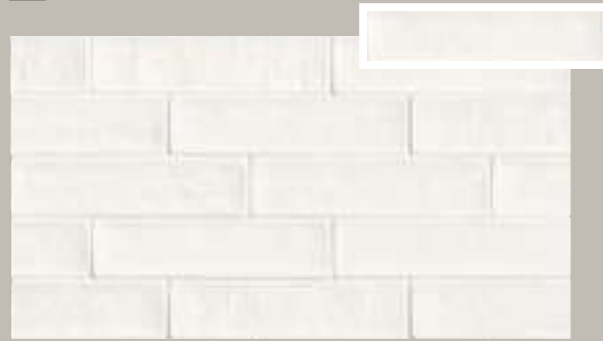

ZELLIGE WHITE MATT 6,2 x 25 (G 27) 2,5" x 10" m²
x 9 mm.

BRILLO
GLOSS



ZELLIGE GREY 6,2 x 25 (G 27) 2,5" x 10" m²
x 9 mm.



ZELLIGE GREEN 6,2 x 25 (G 27) 2,5" x 10" m²
x 9 mm.



ZELLIGE BLACK 6,2 x 25 (G 27) 2,5" x 10" m²
x 9 mm.

PIEZAS ESPECIALES · SPECIAL PIECES



DEMI-BULLNOSE
1,5 x 30 (G 07) 0,6" x 11,8"

PIASTRELLA MIX

Pasta Blanca
WHITE BODY

La serie PIASTRELLA MIX combina con la serie CONVEX MIX - Ver serie en el catálogo CUORE
PIASTRELLA MIX combines with CONVEX MIX collection - Check series in the CUORE catalogue



Rev. / Wall: PIASTRELLA Mix Turchese 5x25



Rev. / Wall: PIASTRELLA Mix Olive 5x25



Rev. / Wall: PIASTRELLA Mix Acqua 5x25

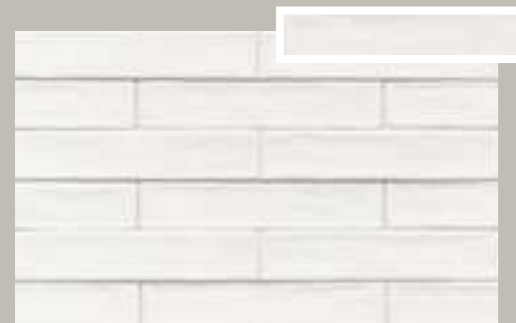

PIASTRELLA NATURALE 5 x 25 (G 27) 2" x 10"
x 10 mm.



PIASTRELLA MIX ROSE 5 x 25 (G 27) 2" x 10"
x 10 mm.



PIASTRELLA MIX ASH 5 x 25 (G 27) 2" x 10"
x 10 mm.



PIASTRELLA MIX ACQUA 5 x 25 (G 27) 2" x 10"
x 10 mm.



PIASTRELLA MIX TURCHESE 5 x 25 (G 27) 2" x 10"
x 10 mm.

SPECIAL ORDER
BAJO PEDIDO



PIASTRELLA MIX BONE 5 x 25 (G 27) 2" x 10"
x 10 mm.



PIASTRELLA MIX CAPUCHINO 5 x 25 (G 27) 2" x 10"
x 10 mm.



PIASTRELLA MIX GREY 5 x 25 (G 27) 2" x 10"
x 10 mm.



PIASTRELLA MIX OLIVE 5 x 25 (G 27) 2" x 10"
x 10 mm.

PIEZAS ESPECIALES · SPECIAL PIECES

DEMI-BULLNOSE
1,5 x 30 (G 07) 0,6" x 11,8"

POOL

PORCELÁNICO
PORCELAIN TILE

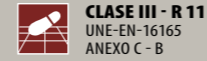

Vaso Piscina / Pool Basin: **Pool Porc. Indigo Antislip Enm. 30,5x30,5**



Vaso Piscina / Pool Basin: **Pool Porc. Iron Antislip Enm. 30,5x30,5**

PIEZAS ESPECIALES · SPECIAL PIECES

- 1 **COMP. INT. CUBRECANTO**
3 x 3 (G 16) 1" x 1" ◆
± 11 mm.
- 2 **CUBRECANTO**
3 x 20 x 3 (G 07) 1" x 8" x 1" ◆
± 11 mm.
- 3 **COMP. EXT. CUBRECANTO**
3 x 3 (G 12) 1" x 1" ◆
± 11 mm.
- 4 **COMP. INT. MEDIA CAÑA**
3 x 3 (G 16) 1" x 1" ◆
± 11 mm.
- 5 **MEDIA CAÑA INT.**
3 x 20 x 3 (G 07) 1" x 8" x 1" ◆
± 11 mm.
- 6 **COMP. INT. MEDIA CAÑA**
3 x 3 (G 12) 1" x 1" ◆
± 11 mm.

BRILLO GLOSS CLASE I - R9

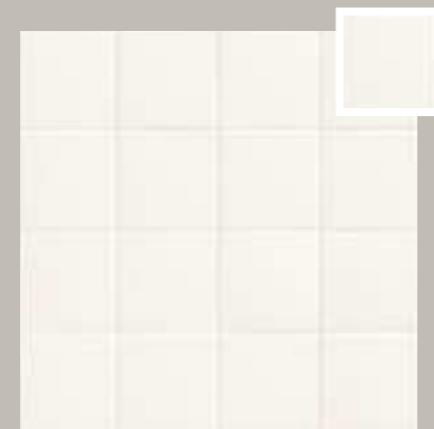

POOL PORC. LUZ
10 x 10 (G 27) 4" x 4"
ENM. 30,5 x 30,5 (G 42) 11,8" x 11,8"
± 9 mm.



POOL PORC. CLOUD
10 x 10 (G 27) 4" x 4"
ENM. 30,5 x 30,5 (G 42) 11,8" x 11,8"
± 9 mm.



POOL PORC. IRON
10 x 10 (G 27) 4" x 4"
ENM. 30,5 x 30,5 (G 42) 11,8" x 11,8"
± 9 mm.

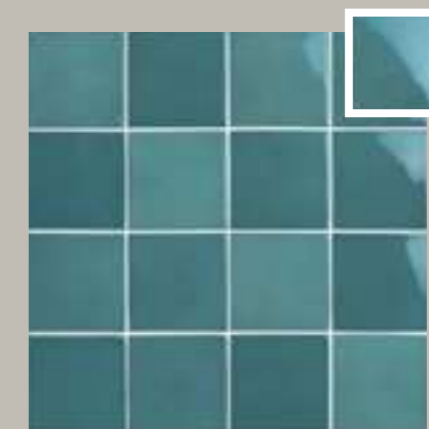

POOL PORC. EMERALD
10 x 10 (G 27) 4" x 4"
ENM. 30,5 x 30,5 (G 42) 11,8" x 11,8"
± 9 mm.

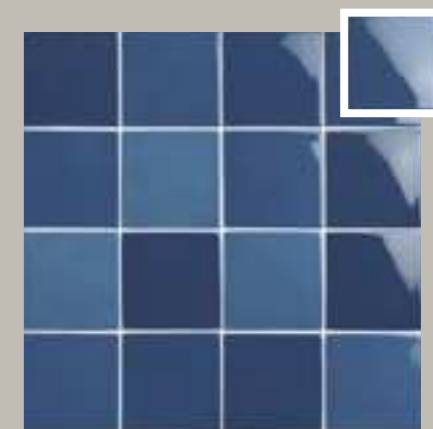

POOL PORC. INDIGO
10 x 10 (G 27) 4" x 4"
ENM. 30,5 x 30,5 (G 42) 11,8" x 11,8"
± 9 mm.

SPECIAL ORDER BAJO PEDIDO

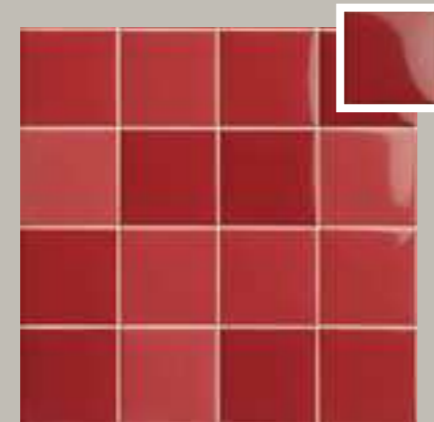

POOL PORC. ROJO
10 x 10 (G 27) 4" x 4"
ENM. 30,5 x 30,5 (G 42) 11,8" x 11,8"
± 9 mm.

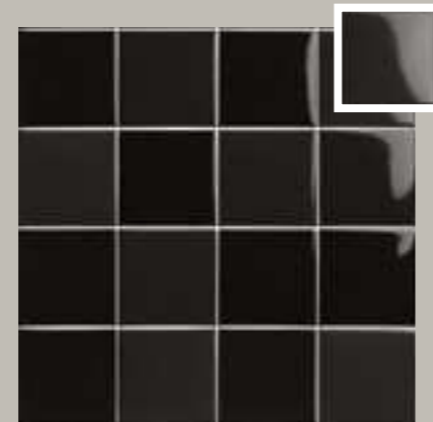

POOL PORC. NEGRO
10 x 10 (G 27) 4" x 4"
ENM. 30,5 x 30,5 (G 42) 11,8" x 11,8"
± 9 mm.

MATE MATT CLASE III - R11



POOL PORC. IRON ANTISLIP
10 x 10 (G 78) 4" x 4"
ENM. 30,5 x 30,5 (G 64) 11,8" x 11,8"
± 9 mm.



POOL PORC. EMERALD ANTISLIP
10 x 10 (G 78) 4" x 4"
ENM. 30,5 x 30,5 (G 64) 11,8" x 11,8"
± 9 mm.

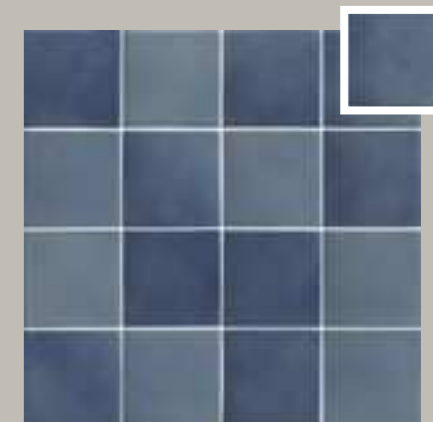

POOL PORC. INDIGO ANTISLIP
10 x 10 (G 78) 4" x 4"
ENM. 30,5 x 30,5 (G 64) 11,8" x 11,8"
± 9 mm.

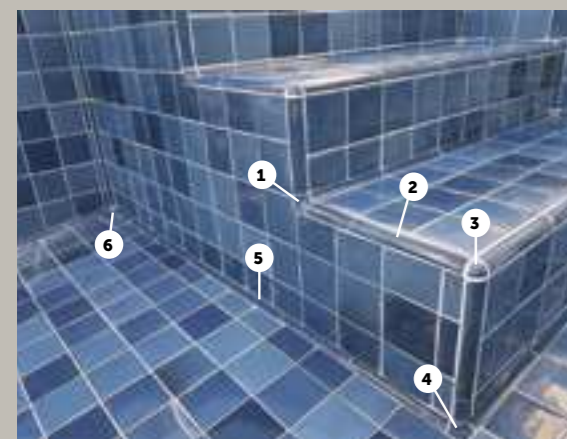

STOW / STOW MIX

Pasta Blanca
WHITE BODY



Rev. / Wall: **Stow Bianco 20x60**



Rev. / Wall: **Stow Grafito 20x60 - Stow Mix Grafito 10x10**



Rev. / Wall: **Stow Mix Olive 10x10**

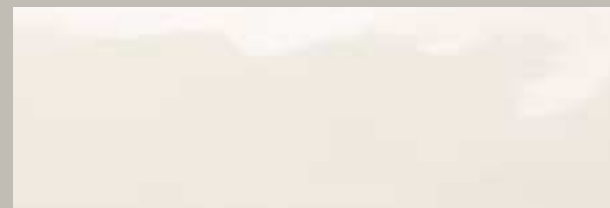

STOW BIANCO 20 x 60 (G 27) 8" x 24" **m**
x 10 mm.

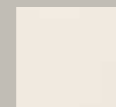

STOW BIANCO 10 x 10 (G 27) 4" x 4" **m**
x 9 mm.



STOW ASH 20 x 60 (G 27) 8" x 24" **m**
x 10 mm.



STOW ASH 10 x 10 (G 27) 4" x 4" **m**
x 9 mm.



STOW MIX ACQUA 10 x 10 (G 27) 4" x 4" **m**
x 9 mm.

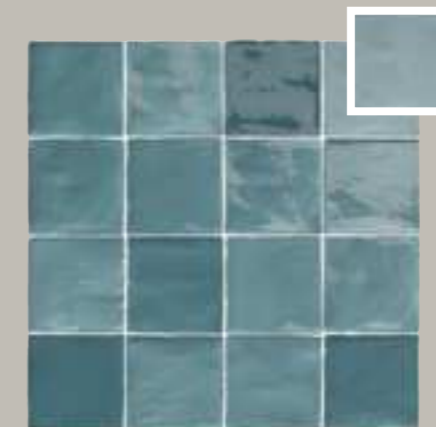

STOW MIX TURCHESE 10 x 10 (G 27) 4" x 4" **m**
x 9 mm.

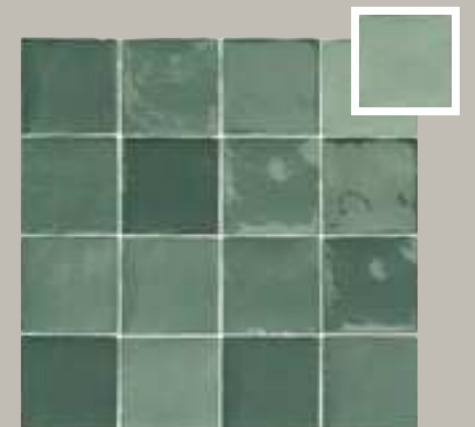

STOW MIX OLIVE 10 x 10 (G 27) 4" x 4" **m**
x 9 mm.

SPECIAL ORDER
BAJO PEDIDO



STOW GRAFITO 20 x 60 (G 27) 8" x 24" **m**
x 10 mm.



STOW GRAFITO 10 x 10 (G 27) 4" x 4" **m**
x 9 mm.

PIEZAS ESPECIALES - SPECIAL PIECES
Disponible en STOW y STOW MIX - Available in STOW & STOW MIX

DEMI-BULLNOSE
1,5 x 30 (G 07) 0,6" x 11,8" **d**

SPECIAL ORDER
BAJO PEDIDO



STOW MIX GREY 10 x 10 (G 27) 4" x 4" **m**
x 9 mm.



STOW MIX GRAFITO 10 x 10 (G 27) 4" x 4" **m**
x 9 mm.

TABARCA

EXTRUSIONADO PORCELÁNICO
EXTRUDED PORCELAIN TILE



Rev. / Wall: Tabarca Sal 11x33 · Tabarca Piano Sal 11x22,5



Rev. / Wall: Tabarca Piano Alga 11x22,5

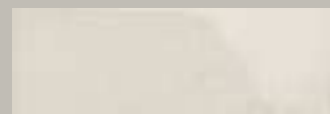

6

TABARCA SAL 11 x 33 (G 73) 4,3" x 13" m^2
x 10 mm.

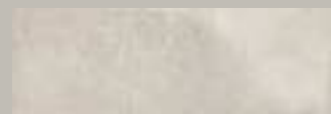

6

TABARCA BRUMA 11 x 33 (G 73) 4,3" x 13" m^2
x 10 mm.



6

TABARCA ALGA 11 x 33 (G 73) 4,3" x 13" m^2
x 10 mm.



6

TABARCA HULLA 11 x 33 (G 73) 4,3" x 13" m^2
x 10 mm.



5

TABARCA PIANO SAL
11 x 22,5 (G 72) 4,3" x 8,8" m^2
x 10 mm.



5

TABARCA PIANO BRUMA
11 x 22,5 (G 72) 4,3" x 8,8" m^2
x 10 mm.



5

TABARCA PIANO ALGA
11 x 22,5 (G 72) 4,3" x 8,8" m^2
x 10 mm.

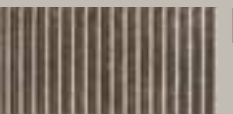

5

TABARCA PIANO HULLA
11 x 22,5 (G 72) 4,3" x 8,8" m^2
x 10 mm.

PIEZAS ESPECIALES - SPECIAL PIECES



DEMI-BULLNOSE
1,5 x 30 (G 07) 0,6" x 11,8" ◆



TABARCA

EXTRUSIONADO PORCELÁNICO
EXTRUDED PORCELAIN TILE

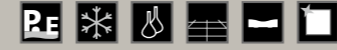

Rev. / Wall: Tabarca Bruma 11x33 • Tabarca Faro 11x33



Pav. / Floor: Tabarca Levante 22,5x22,5



Pav. / Floor: Tabarca Mistral 22,5x22,5

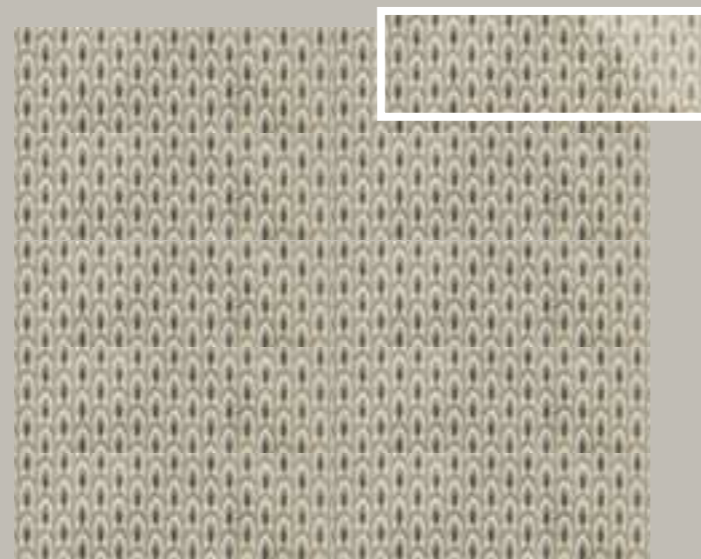

TABARCA FARO 11 x 33 (G 79) 4,3" x 13" m^2
X 10 mm.

18



TABARCA LEVANTE 22,5 x 22,5 (G 73) 8,8" x 8,8" m^2
X 10 mm.

36



TABARCA MISTRAL 22,5 x 22,5 (G 73) 8,8" x 8,8" m^2
X 10 mm.

36

FRAME

EXTRUSIONADO PORCELÁNICO
EXTRUDED PORCELAIN TILE

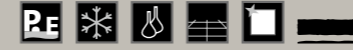

Rev. / Wall: **Frame Beige 15x30**
Pav. / Floor: **American Melrose Mix 22,5x22,5**



Rev. / Wall: **Frame Sage 15x30**
Pav. / Floor: **Frame Sage 15x30**



Rev. / Wall: **Frame White 15x30** · **Frame Blue 15x30**



Rev. / Wall: **Frame Blue 15x30** · **Frame Santorini 15x30**
Pav. / Floor: **Argile Verona 45x45**



FRAME BEIGE 15 x 30 (G 25) 6" x 12" **m²**
X 10 mm.

1



FRAME SAGE 15 x 30 (G 25) 6" x 12" **m²**
X 10 mm.

1



FRAME WHITE 15 x 30 (G 25) 6" x 12" **m²**
X 10 mm.

1

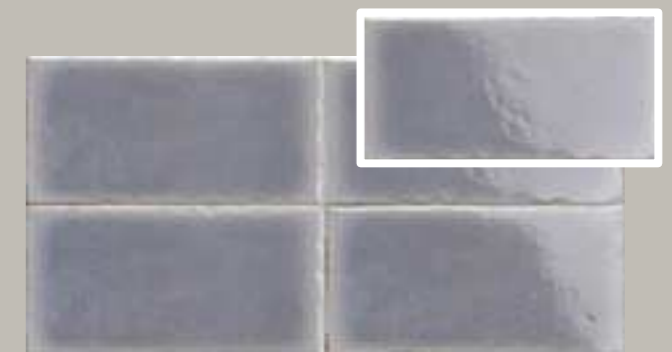

FRAME BLUE 15 x 30 (G 25) 6" x 12" **m²**
X 10 mm.

1

SPECIAL ORDER
BAJO PEDIDO



FRAME RODAS 15 x 30 (G 73) 6" x 12" **m²**
X 10 mm.

4



FRAME SANTORINI 15 x 30 (G 73) 6" x 12" **m²**
X 10 mm.

4

PIEZAS ESPECIALES - SPECIAL PIECES

DEMI-BULLNOSE
1,5 x 30 (G 07) 0,6" x 11,8"



Rev. / Wall: Tempo Sack Rice 11x22,5



Rev. / Wall: Tempo Sand 11x22,5



28

TEMPO SACK RICE
11 x 22,5 (G 56) 4,3" x 8,8" m²
X 9 mm.



28

TEMPO RICE
11 x 22,5 (G 58) 4,3" x 8,8" m²
X 9 mm.

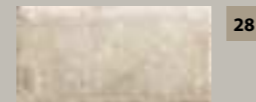

28

TEMPO SAND
11 x 22,5 (G 58) 4,3" x 8,8" m²
X 9 mm.



28

TEMPO ATLANTIC
11 x 22,5 (G 58) 4,3" x 8,8" m²
X 9 mm.



28

TEMPO FOSSIL
11 x 22,5 (G 58) 4,3" x 8,8" m²
X 9 mm.



28

TEMPO CAVIAR
11 x 22,5 (G 58) 4,3" x 8,8" m²
X 9 mm.

PIEZAS ESPECIALES · SPECIAL PIECES

SPECIAL ORDER
BAJO PEDIDO



VIERTEAGUAS
15 x 22,5/4 (G 10) 5,9" x 8,8" ◆



DEMI-BULLNOSE
1,5 x 30 (G 07) 0,6" x 11,8" ◆



Rev. / Wall: **Tempo Motif Rice 11x11**
Pav. / Floor: **Tempo Motif Rice 11x11**



Pav. / Floor: **Tempo Pattern Caviar 22,5x22,5**



Rev. / Wall: **Tempo Roads Caviar 22,5x22,5**
Pav. / Floor: **Tempo Roads Caviar 22,5x22,5**



TEMPO MOTIF RICE 11 x 11 (G 56) 4,3" x 4,3" **m²**
± 9 mm.

14



TEMPO PATTERN CAVIAR 22,5 x 22,5 (G 57) 8,8" x 8,8" **m²**
± 9 mm.

14



TEMPO ROADS CAVIAR 22,5 x 22,5 (G 57) 8,8" x 8,8" **m²**
± 9 mm.

14



TEMPO ROADS CAVIAR PERMITE MÚLTIPLES POSIBILIDADES COMPOSITIVAS
TEMPO ROADS CAVIAR OFFERS INFINITE COMPOSITIVE POSSIBILITIES

MARE NOSTRUM

EXTRUSIONADO PORCELÁNICO
EXTRUDED PORCELAIN TILE



Rev. / Wall: Mare Nostrum Messina 7x45 · Mare Nostrum Ibiza 7x45



Pav. / Floor: Mare Nostrum Hex Niza 18x20,5



Rev. / Wall: Provenzal Niza 26,5x20,5 · Provenzal Ibiza 26,5x20,5
Pav. / Floor: Provenzal Niza 26,5x20,5 · Provenzal Ibiza 26,5x20,5

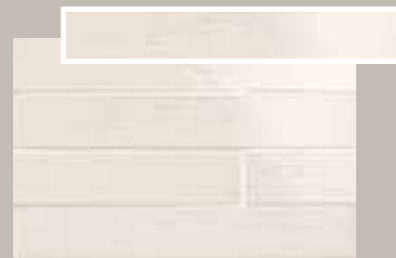

MARE NOSTRUM IBIZA
7 x 45 (G 27) 3" x 17,7" **m²**
± 9 mm.



MARE NOSTRUM IBIZA
18 x 18 (G 57) 7" x 7" **m²**
± 9 mm.



MARE NOSTRUM MESSINA
7 x 45 (G 27) 3" x 17,7" **m²**
± 9 mm.



MARE NOSTRUM MESSINA
18 x 18 (G 57) 7" x 7" **m²**
± 9 mm.



MARE NOSTRUM MÓNACO
7 x 45 (G 27) 3" x 17,7" **m²**
± 9 mm.



MARE NOSTRUM NIZA
7 x 45 (G 27) 3" x 17,7" **m²**
± 9 mm.



MARE NOSTRUM NIZA
18 x 18 (G 57) 7" x 7" **m²**
± 9 mm.



MARE NOSTRUM GÉNOVA
7 x 45 (G 27) 3" x 17,7" **m²**
± 9 mm.



MARE NOSTRUM GÉNOVA
18 x 18 (G 57) 7" x 7" **m²**
± 9 mm.

PIEZAS ESPECIALES · SPECIAL PIECES

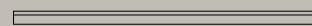

DEMI-BULLNOSE
1,5 x 30 (G 07) 0,6" x 11,8" **m²**

SPECIAL ORDER BAJO PEDIDO



MARE NOSTRUM HEX. IBIZA



PROVENZAL IBIZA

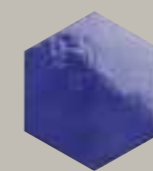

MARE NOSTRUM HEX. MESSINA

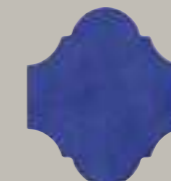

PROVENZAL MESSINA

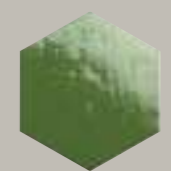

MARE NOSTRUM HEX. MÓNACO

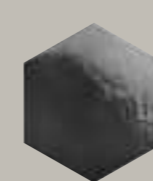

MARE NOSTRUM HEX. NIZA



PROVENZAL NIZA

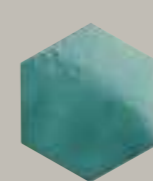

MARE NOSTRUM HEX. GÉNOVA

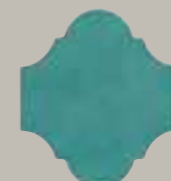

PROVENZAL GÉNOVA

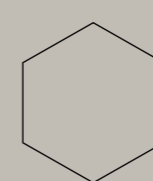

18 x 20,5 (G 39)
7" x 8" **m²**
± 10 mm.

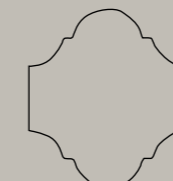

26,5 x 20,5 (G 55)
10,3" x 8" **m²**
± 10 mm.

Packing Bases

PAVIMENTO FLOOR TILE / SOLS

| | FORMATO | ESPEJOR | PULGADAS | PZ CAJA | M² | CAJA PLT | PESO CAJA | PESO PLT |
|---------------------|-------------|-----------|-----------------|---------|-------|----------|------------|------------|
| | SIZE | THICKNESS | SIZES IN INCHES | PC BOX | M² | BOX PLT | WEIGHT BOX | WEIGHT PLT |
| ALQUEZAR | 20 x 120 | 9 | 8" x 48" | 5 | 1,2 | 48 | 24,27 | 1.180 |
| ALMA | 90 x 90 | 9,5 | 35,4" x 35,4" | 2 | 1,62 | 27 | 39,70 | 1.090 |
| ALPES | 60 x 120 | 9 | 23,6" x 48" | 2 | 1,44 | 36 | 29,03 | 1.060 |
| ANIMA | 90 x 90 | 9 | 35,4" x 35,4" | 2 | 1,62 | 32 | 33,1 | 1.074 |
| | 22,5 x 22,5 | 10 | 8,8" x 8,8" | 20 | 1,01 | 66 | 20,7 | 1.505 |
| ARGILE | 22,5 x 22,5 | 12 | 8,8" x 8,8" | 16 | 0,81 | 72 | 21 | 1.560 |
| | 22,5 x 45 | 12 | 8,8" x 17,7" | 8 | 0,81 | 72 | 21 | 1.560 |
| | 45 x 45 | 12 | 17,7" x 17,7" | 5 | 1,01 | 64 | 27,1 | 1.738,88 |
| | 15 x 15 | 10 | 5,9" x 5,9" | 19 | 0,43 | 120 | 9,5 | 1.150 |
| | 4 x 4 | 10 | 2" x 2" | 120 | 0,192 | 112 | 4,8 | 565 |
| ARGILE ARROW | 7,4 x 48 | 10 | 3" x 19" | 20 | 0,71 | 65 | 16 | 1.060 |
| ARGILE STAR | 18 x 18 | 10 | 7" x 7" | 16 | 0,60 | 60 | 12,8 | 800 |
| ARGILE CRUZ | 18 x 18 | 10 | 7" x 7" | 16 | 0,52 | 60 | 9,17 | 565 |
| ARGILE LOSG. | 18 x 45 | 12 | 7" x 17,7" | 11 | 4,95 | 40 | 13 | 530 |
| ARGILE DECOR | 22,5 x 22,5 | 10 | 8,8" x 8,8" | 20 | 1,01 | 66 | 20,98 | 1.533 |
| | 15 x 45 | 10 | 5,9" x 17,7" | 12 | 0,81 | 75 | 18 | 1.332 |
| ARTIES | 30,3 x 61,3 | 10 | 12" x 24" | 7 | 1,30 | 40 | 25 | 1.000 |
| BOSTON | 6,5 x 25 | 10 | 2,5" x 10" | 27 | 0,439 | 121 | 9,6 | 1.705 |
| | 25 x 50 | 10 | 10" x 20" | 6 | 0,75 | 40 | 15,90 | 651 |
| | 22,5 x 45 | 10 | 8,8" x 17,7" | 10 | 1,01 | 72 | 21,2 | 1.540 |
| | 11 x 22,5 | 10 | 4,3" x 8,8" | 20 | 1 | 66 | 10,5 | 1.359 |
| | 22,5 x 22,5 | 10 | 8,8" x 8,8" | 20 | 1,01 | 66 | 20,07 | 1.505 |
| | 36 x 36 | 10 | 14" x 14" | 8 | 1 | 48 | 22,04 | 1.072 |
| BOSTON HEX | 28,5 x 32,5 | 10 | 11,2" x 12,7" | 15 | 1,05 | 48 | 21,9 | 1.063 |
| BOSTON HEX | 36 x 41,5 | 10 | 14" x 16,2" | 9 | 1 | 48 | 22,6 | 1.103 |
| BOTANICA | 25 x 150 | 10 | 10" x 60" | 4 | 1,5 | 40 | 35 | 1.420 |
| CERELR | 33,3 x 33,3 | 10 | 13,1" x 13,1" | 12 | 1,33 | 48 | 24,50 | 1.176 |
| COTTO NATURE | 36 x 36 | 10 | 14" x 14" | 8 | 1 | 48 | 22,04 | 1.072 |
| | 18 x 36 | 10 | 7" x 14" | 16 | 1 | 72 | 22,8 | 1.660 |
| | 18 x 18 | 10 | 7" x 7" | 30 | 0,97 | 48 | 21,4 | 1.555 |
| | 30 x 30 | 9 | 11,8" x 11,8" | 11 | 1 | 48 | 18,95 | 1.380 |
| CTO. NATURE LOSAGNA | 18 x 36 | 9 | 7" x 14" | 16 | 1,04 | 72 | 22,82 | 1.657 |
| COTTAGE | 60 x 60 | 12 | 23,6" x 23,6" | 4 | 1,44 | 24 | 36 | 1.296 |
| | 30 x 30 | 12 | 11,8" x 11,8" | 9 | 0,82 | 48 | 22 | 1.555 |
| | 4 x 4 | 12 | 1,5" x 1,5" | 120 | 4,80 | 112 | 4,8 | 564 |
| COTTAGE STAR | 15,5 x 15,5 | 10 | 6" x 6" | 16 | 0,39 | 120 | 9 | 1.085 |
| COTTAGE CROSS | 15,5 x 15,5 | 10 | 6" x 6" | 24 | 0,59 | 80 | 10 | 780 |
| COTTO BRICK | 7 x 60 | 10 | 3" x 24" | 24 | 1 | 66 | 22,5 | 1.480 |
| D'ANTICATTO | 22,5 x 22,5 | 10 | 8,8" x 8,8" | 20 | 1,01 | 66 | 20,7 | 1.505 |
| | 22,5 x 45 | 10 | 8,8" x 17,7" | 10 | 1,01 | 72 | 21,2 | 1.540 |
| | 11 x 22,5 | 10 | 4,3" x 8,8" | 20 | 1 | 66 | 10,5 | 1.359 |
| FIORANO | 15 x 15 | 10 | 5,9" x 5,9" | 19 | 0,43 | 120 | 9,5 | 1.150 |
| | 15 x 45 | 10 | 5,9" x 17,7" | 12 | 0,81 | 75 | 18 | 1.332 |
| FUEGO | 45 x 45 | 12 | 17,7" x 17,7" | 5 | 1,01 | 64 | 27,1 | 1.738,88 |
| | 22,5 x 22,5 | 12 | 8,8" x 8,8" | 16 | 0,81 | 72 | 21 | 1.560 |
| | 15 x 30 | 11 | 6" x 12" | 19 | 0,86 | 52 | 20 | 1.040 |

| | FORMATO | ESPEJOR | PULGADAS | PZ CAJA | M² | CAJA PLT | PESO CAJA | PESO PLT |
|--------------------|--------------|-----------|-----------------|---------|-------|----------|------------|------------|
| | SIZES | THICKNESS | SIZES IN INCHES | PC BOX | M² | BOX PLT | WEIGHT BOX | WEIGHT PLT |
| FUEGO | 6,5 x 25 | 11 | 2,5" x 10" | 27 | 0,44 | 121 | 9,58 | 1.180 |
| HERITAGE GLAY | 120 x 120 | 8 | 48" x 48" | 1 | 1,44 | 50 | 27 | 1.350 |
| | 60 x 120 x 2 | 20 | 24" x 48" x 1" | 2 | 1,44 | 18 | 58,50 | 1.053 |
| | 60 x 90 x 2 | 20 | 24" x 36" x 1" | 2 | 1,08 | 22 | 45 | 990 |
| | 60 x 120 | 8 | 24" x 48" | 2 | 1 | 40 | 27 | 1.080 |
| | 60 x 60 | 8 | 24" x 24" | 4 | 1,44 | 40 | 23 | 966 |
| | 30 x 60 | 8 | 12" x 24" | 8 | 1,44 | 48 | 26,50 | 1.272 |
| | 30 x 30 ENM | 8 | 12" x 12" | 11 | 1 | 42 | 23 | 966 |
| LANDS | 60 x 60 | 12 | 23,6" x 23,6" | 4 | 1,44 | 24 | 36 | 1.296 |
| | 45 x 45 | 12 | 17,7" x 17,7" | 5 | 1,012 | 52 | 27,17 | 1.760 |
| | 22,5 x 22,5 | 12 | 8,8" x 8,8" | 16 | 0,81 | 66 | 21,41 | 1.557 |
| | 11 x 22,5 | 10 | 4,3" x 8,8" | 20 | 0,8 | 66 | 10,5 | 1.359 |
| LANDS STAR | 15,5 x 15,5 | 10 | 6" x 6" | 16 | 0,39 | 120 | 9 | 1.085 |
| LANDS CROSS | 15,5 x 15,5 | 10 | 6" x 6" | 24 | 0,59 | 80 | 10 | 780 |
| LIMESTONE | 60 x 60 | 11 | 23,6" x 23,6" | 4 | 1,44 | 24 | 36 | 1.296 |
| | 30 x 30 | 12 | 11,8" x 11,8" | 9 | 0,82 | 48 | 22 | 1.555 |
| LIMESTONE STAR | 15,5 x 15,5 | 10 | 6" x 6" | 16 | 0,39 | 120 | 9 | 1.085 |
| LIMESTONE CROSS | 15,5 x 15,5 | 10 | 6" x 6" | 24 | 0,59 | 80 | 10 | 780 |
| NATUR-TECH | 20 x 90/2,6 | 26 | 8" x 35,4"/1" | 2 | 0,36 | 48 | 16 | 783 |
| | 20 x 45/2,6 | 26 | 8" x 17,7"/1" | 4 | 0,36 | 80 | 16 | 1.295 |
| NATUR-TRANSIT | 20 x 20/2 | 20 | 8" x 8" | 12 | 0,48 | 64 | 21,3 | 1.380 |
| | 20 x 30/2 | 20 | 8" x 11,8" | 9 | 0,54 | 64 | 23,85 | 1.543 |
| NATUR-TRANSIT GO | 20 x 20 | 20 | 8" x 8" | 12 | 0,48 | 64 | 21,70 | 1.404 |
| NATUR-TRANSIT STOP | 20 x 20 | 20 | 8" x 8" | 12 | 0,48 | 64 | 22,9 | 1.481 |
| NATURA | 25 x 150 | 10 | 10" x 60" | 4 | 1,5 | 40 | 35 | 1.420 |
| | 20 x 120 | 9 | 8" x 48" | 5 | 1,2 | 48 | 24,27 | 1.180 |
| OLIMPO | 60 x 120 | 9 | 23,6" x 48" | 2 | 1,44 | 36 | 29,03 | 1.060 |
| ORION | 90 x 90 | 9 | 35,4" x 35,4" | 2 | 1,62 | 32 | 33,1 | 1.074 |
| PARK | 20 x 120 | 9 | 8" x 48" | 5 | 1,2 | 48 | 24,27 | 1.180 |
| PIEDRAS DEL BRUC | 45 x 67,5 | 12 | 17,7" x 26,5" | 5 | 1,52 | 32 | 41,75 | 1.350 |
| | 22,5 x 67,5 | 12 | 8,8" x 26,5" | 7 | 1,06 | 48 | 29,05 | 1.410 |
| PIEMONTE | 36 x 36 | 10 | 14" x 14" | 8 | 1 | 48 | 22,04 | 1.072 |
| | 18 x 36 | 9 | 7" x 14" | 16 | 1 | 48 | 22,8 | 1.660 |
| | 18 x 18 | 9 | 7" x 7" | 30 | 0,97 | 48 | 21,4 | 1.555 |
| | 4 x 4 | 9 | 2" x 2" | 120 | 0,192 | 110 | 4,8 | 565 |
| | 5 x 5 | 9 | 2" x 2" | 115 | 0,29 | 112 | 2,7 | 318 |
| PIEMONTE STAR | 15,5 x 15,5 | 9 | 6" x 6" | 20 | 0,48 | 60 | 11,5 | 705 |
| PIEMONTE LOSG. | 15,5 x 36 | 9 | 6" x 14" | 16 | 0,89 | 60 | 20,26 | 1.150 |
| PIEMONTE LOSG. | 18 x 36 | 9 | 7" x 14" | 16 | 1,04 | 72 | 22,82 | 1.657 |
| PIRINEOS | 33 x 66,5 | 9 | 13" x 26,5" | 7 | 1,54 | 48 | 30,1 | 1.465 |
| | 15 x 15 | 9 | 6" x 6" | 22 | 0,5 | 110 | 8,9 | 994 |
| POSETS | 18 x 36 | 9 | 7" x 14" | 16 | 1 | 48 | 22,8 | 1.660 |
| | 18 x 18 | 9 | 7" x 7" | 30 | 0,97 | 48 | 21,4 | 1.555 |
| POSETS A/S | 60 x 120 | 9 | 23,6" x 48" | 2 | 1,44 | 36 | 29,03 | 1.060 |
| | 36 x 72 | 9 | 14" x 28" | 5 | 1,25 | 48 | 27,25 | 1.325 |
| | 36 x 36 | 9 | 14" x 14" | 8 | 1 | 48 | 22,04 | 1.072 |

| | FORMATO | ESPEJOR | PULGADAS | PZ CAJA | M² | CAJA PLT | PESO CAJA | PESO PLT |
|-----------------|--------------|-----------|-----------------|---------|-------|----------|------------|------------|
| | SIZES | THICKNESS | SIZES IN INCHES | PC BOX | M² | BOX PLT | WEIGHT BOX | WEIGHT PLT |
| RETRO | 21 x 60 | 10 | 8" x 23,6" | 8 | 1 | 72 | 21,5 | 1.580 |
| | 7 x 60 | 10 | 3" x 23,6" | 24 | 1 | 66 | 22,25 | 1.483 |
| RETRO HEX | 36 x 41,5 | 10 | 14" x 16,2" | 9 | 1 | 48 | 22,6 | 1.103 |
| SANDRO | 6,5 x 6,5 | 10 | 3" x 3" | 60 | 3,9 | 60 | 4,90 | 309 |
| SARSEN STONE | 160 x 160 | 8 | 64" x 64" | 1 | 2,56 | 20 | 48,62 | 972,40 |
| | 120 x 120 | 8 | 48" x 48" | 1 | 1,44 | 50 | 27 | 1.350 |
| | 60 x 120 x 2 | 20 | 24" x 48" x 1" | 2 | 1,44 | 18 | 58,50 | 1.053 |
| | 60 x 90 x 2 | 20 | 24" x 36" x 1" | 2 | 1,08 | 22 | 45 | 990 |
| | 60 x 120 | 8 | 24" x 48" | 2 | 1 | 40 | 27 | 1.080 |
| | 60 x 60 | 8 | 24" x 24" | 4 | 1,44 | 40 | 23 | 966 |
| | 30 x 60 | 8 | 12" x 24" | 8 | 1,44 | 48 | 26,50 | 1.272 |
| | 30 x 30 ENM | 8 | 12" x 12" | 11 | 1 | 42 | 23 | 966 |
| SAONA | 30,3 x 61,3 | 10 | 12" x 24" | 7 | 1,30 | 40 | 25 | 1.000 |
| SHERWOOD | 30 x 180 | 10 | 11,8" x 72" | 1 | 0,62 | 50 | 45 | 2.250 |
| | 25 x 150 | 10 | 10" x 60" | 4 | 2,67 | 40 | 35 | 1.400 |
| | 20 x 120 | 9 | 8" x 48" | 7 | 4,17 | 44 | 32 | 1.408 |
| TECH GEO | 22,5 x 33 | 14 | 8,8" x 13" | 11 | 0,82 | 68 | 23,80 | 1.640 |
| | 22,5 x 22,5 | 14 | 8,8" x 8,8" | 17 | 0,86 | 60 | 23,19 | 1.406 |
| | 11 x 22,5 | 14 | 4,3" x 8,8" | 20 | 0,5 | 128 | 14,1 | 1.820 |
| TECH LAND | 30 x 30 | 14 | 11,8" x 11,8" | 10 | 0,90 | 60 | 25 | 1.520 |
| | 22,5 x 33 | 14 | 8,8" x 13" | 11 | 0,82 | 68 | 23,80 | 1.640 |
| | 11 x 22,5 | 14 | 4,3" x 8,8" | 20 | 0,5 | 128 | 14,1 | 1.820 |
| | 22,5 x 22,5 | 14 | 8,8" x 8,8" | 17 | 0,86 | 60 | 23,19 | 1.406 |
| TECH LAND STAR | 15,5 x 15,5 | 14 | 6" x 6" | 12 | 0,34 | 96 | 9,9 | 966 |
| TECH LAND CROSS | 15,5 x 15,5 | 14 | 6" x 6" | 18 | 0,43 | 105 | 10,40 | 1.107 |
| TOSCANA | 33,3 x 33,3 | 10 | 13,1" x 13,1" | 12 | 1,33 | 48 | 24,50 | 1.176 |
| UNIKA | 22,5 x 22,5 | 10 | 8,8" x 8,8" | 20 | 1,01 | 66 | 20,7 | 1.505 |
| | 22,5 x 45 | 10 | 8,8" x 17,7" | 10 | 1,01 | 72 | 21,1 | 1.540 |
| | 11 x 22,5 | 10 | 4,3" x 8,8" | 40 | 1 | 66 | 21,22 | 1.542 |
| | 4 x 4 | 10 | 2" x 2" | 120 | 0,192 | 112 | 4,8 | 565 |
| UNIKA STAR | 15,5 x 15,5 | 10 | 6" x 6" | 16 | 0,39 | 120 | 9 | 1.085 |
| UNIKA CROSS | 15,5 x 15,5 | 10 | 6" x 6" | 24 | 0,59 | 80 | 10 | 780 |
| VENICE | 15 x 45 | 10 | 5,9" x 17,7" | 12 | 0,81 | 75 | 18 | 1.332 |
| VENICE | 4 x 4 | 10 | 2" x 2" | 120 | 0,192 | 112 | 4,8 | 565 |
| VENICE | 5 x 5 | 10 | 2" x 2" | 115 | 0,29 | 112 | 2,7 | 318 |
| VENICE | 18 x 18 | 10 | 7" x 7" | 16 | 0,60 | 60 | 12,8 | 800 |
| VENICE | 15 x 15 | 10 | 5,9" x 5,9" | 19 | 0,43 | 120 | 9,5 | 1.150 |
| VERSILIA | 4 x 4 | 10 | 2" x 2" | 120 | 0,192 | 112 | 4,8 | 565 |
| | 5 x 5 | 10 | 2" x 2" | 115 | 0,29 | 112 | 2,7 | 348 |
| | 8 x 8 | 10 | 3" x 3" | 25 | 0,16 | 72 | 3,35 | 256 |
| | 8 x 36 | 10 | 3" x 14" | 30 | 0,86 | 72 | 18,10 | 1.318 |
| | 15,5 x 36 | 10 | 6" x 14" | 15 | 0,84 | 72 | 18,1 | 1.318 |
| VERSILIA FRNT. | 15,5 x 15,5 | 10 | 6" x 6" | 32 | 0,77 | 565 | 18,3 | 1.042 |
| VERSILIA ESTR. | 15,5 x 15,5 | 10 | 6" x 6" | 15 | 0,36 | 60 | 8,55 | 534 |
| VERSILIA ESTR. | 18 x 18 | 10 | 7" x 7" | 15 | 0,48 | 60 | 10,75 | 660 |
| VERSILIA ESTR. | 36 x 36 | 10 | 14" x 14" | 8 | 1,04 | 40 | 22,5 | 915 |
| VOLTERRA | 4 x 4 | 10 | 2" x 2" | 120 | 0,192 | 112 | 4,8 | 565 |
| ZERMATT | 25 x 150 | 10 | 10" x 60" | 3 | | | | |

Packing Piezas Especiales

PIEZAS ESPECIALES PAVIMENTO SPECIAL PIECES FLOOR TILE / PIÈCES SPÉCIALES POUR REVÊTEMENT DE SOL



| | FORMATO | ESPESOR | PULGADAS | PZ CAJA | ML | CAJA PLT | PESO CAJA | PESO PLT |
|--------------------------------|--------------------|-----------|--------------------------|---------|------|----------|------------|------------|
| | SIZES | THICKNESS | SIZES IN INCHES | PC BOX | ML | BOX PLT | WEIGHT BOX | WEIGHT PLT |
| ÁNG. GRATING | 25 x 50 x 35/2,2 | 22 | 10" x 20" x 15"/1" | 4 | 2 | 45 | 16 | 735 |
| ÁNG. PELD. ANG. | 32 x 45/3 | 11 | 12,5" x 17,7"/1" | 2 | 0,32 | 90 | 3,20 | 300 |
| | 32 x 45/4 | 11 | 12,5" x 17,7"/1,5" | 2 | 0,32 | 90 | 3,16 | 308 |
| ÁNG. PELD. ANG. INT./EXT. | 66,5 x 32 x 45/3 | 11 | 26,5" x 12,5" x 17,7"/1" | 2 | 1,35 | 20 | 10,1 | 217 |
| | 67,5 x 32 x 45/3 | 11 | 26,5" x 12,5" x 17,7"/1" | 2 | 1,35 | 20 | 10,2 | 220 |
| ÁNG. PELD. CV 4 PZ. | 33 x 33/4 | 12 | 13" x 13"/1,5" | 1 | 0,33 | 90 | 3,46 | 325 |
| ÁNG. PELD. CV. | 33 x 46/4 | 12 | 13" x 18"/1,5" | 2 | 0,33 | 90 | 3,46 | 325 |
| ÁNG. PELD. RCT. | 33 x 45/3 | 11 | 13" x 17,7"/1" | 2 | 0,32 | 90 | 3,4 | 326 |
| ÁNG. PELD. ANG. 120 INT./EXT. | 120 x 32 x 45/3 | 11 | 48" x 12,5" x 17,7"/1" | 2 | 2,4 | 14 | 18 | 267 |
| ÁNG. PELD. RCT. 120 INT./EXT. | 120 x 33 x 45/3 | 11 | 48" x 13" x 17,7"/1" | 2 | 2,4 | 14 | 18 | 253 |
| ÁNG. PELD. RCT. 150 INT./EXT. | 150 x 33 x 45/3 | 11 | 60" x 13" x 17,7"/1" | 2 | 3 | 16 | 22,5 | 375 |
| ÁNG. PELD. RCT. 61,3 INT./EXT. | 61,3 x 32 x 46/3 | 11 | 24" x 12,5" x 18"/1" | 2 | 0,29 | 28 | 18 | 504 |
| BORDE PISCINA | 28 x 66,5/4 | 40 | 10" x 26,5"/1,5" | 2 | 1,35 | 32 | 22 | 719 |
| | 28 x 67,5/4 | 40 | 10" x 26,5"/1,5" | 2 | 1,35 | 32 | 22 | 719 |
| | 45 x 120/3 | 30 | 17,7" x 48"/1" | 1 | 0,54 | 38 | 14,50 | 551 |
| | 45 x 60/3 | 30 | 17,72 x 24"/1" | - | - | - | - | - |
| | 61,3 x 28/4 | 40 | 24" x 11"/15" | 2 | 0,35 | 32 | 20,08 | 643 |
| CANALETA | 15 x 20/2 | 20 | 5,9" x 8"/1" | 9 | 1,8 | 120 | 7,26 | 899 |
| CANALETA DESAGÜE | 15 x 20/2 | 20 | 5,9" x 8"/1" | 9 | 1,8 | 120 | 6,40 | 795 |
| C. EXT. MEDIA CAÑA | 4 x 4 | 20 | 1,5" x 1,5" | 18 | 0,6 | - | 1,34 | - |
| C. INT. MEDIA CAÑA | 4 x 4 | 20 | 1,5" x 1,5" | 20 | 0,66 | - | 1,84 | - |
| C. EXT. CUBRECANTO | 4 x 4 | 20 | 1,5" x 1,5" | 25 | 0,83 | - | 0,55 | - |
| C. INT. CUBRECANTO | 4 x 4 | 20 | 1,5" x 1,5" | 10 | 0,33 | - | 0,85 | - |
| C. EXT. ZÓCALO ANG. | 4 x 4 | 20 | 2,5" x 1,5" | 18 | 0,72 | - | 2,6 | - |
| C. INT. ZÓCALO ANG. | 4 x 4 | 20 | 2,5" x 1,5" | 18 | 0,72 | - | 1,75 | - |
| CUBRECANTO | 4 x 30 x 4 | 20 | 1,5" x 11,8" x 1,5" | 26 | 7,8 | - | 7,33 | - |
| ESQ. INT./EXT. DESBORD. | 30,5 x 50 x 40/2,4 | 24 | 11,8" x 20" x 16"/1" | 4 | 2 | 38 | 14,50 | 566 |
| DEMI-BULLNOSE | 1,5 x 30 | 8 | 0,6" x 11,8" | 50 | 15 | 120 | 2,2 | 276 |
| DESBORDANTE | 30,5 x 50/2,4 | 24 | 11,8" x 20"/1" | 4 | 2 | 38 | 19,40 | 762 |
| ESQ. EXT./INT. BORDE PISCINA | 28 x 66,5 x 43/4 | 40 | 10" x 26,5" x 17"/1,5" | 2 | 1,35 | 32 | 16,50 | 545 |
| | 28 x 67,5 x 43,5/4 | 40 | 10" x 26,5" x 17"/1,5" | 2 | 1,35 | 32 | 16,50 | 545 |
| | 61,3 x 28 x 43,5/4 | | 24" x 12" x 16"/1" | | | | | |
| FRONTAL | 15 x 120 | 9 | 6" x 48" | 8 | 9,6 | 14 | 33,7 | 490 |
| GRATING | 25 x 50/2,2 | 22 | 10" x 20"/1" | 5 | 2,5 | 42 | 21,2 | 905 |
| MEDIA CAÑA INT. | 4 x 30 x 4 | 20 | 1,5" x 11,8" x 1,5" | 22 | 6,6 | - | 9,91 | - |
| PASAMANOS | 18 x 33,3/4 | 12 | 7" x 13,1"/1,5" | 7 | 0,42 | 70 | 15 | 1.050 |
| PELDAÑO ANG. | 32 x 32/4 | 12 | 12,5" x 12,5"/1,5" | 4 | 1,28 | 54 | 11,55 | 640 |
| | 120 x 32/3 | 11 | 48" x 12,5"/1" | 2 | 2,4 | 14 | 19,2 | 284 |
| | 60 x 32/3 | 11 | 23,6" x 12,5"/1" | 2 | 1,2 | 28 | 9,6 | 284 |
| | 66,5 x 32/3 | 11 | 26,5" x 12,5"/1" | 2 | 1,35 | 20 | 13,7 | 289 |
| | 67,5 x 32/3 | 11 | 26,5" x 12,5"/1" | 2 | 1,35 | 20 | 13,7 | 289 |
| PELDAÑO CV. | 22,5 x 33/4 | 12 | 8,8" x 13"/1,5" | 6 | 1,35 | 64 | 13 | 845 |
| PELDAÑO CV. | 30 x 33/4 | 12 | 11,8" x 13"/1,5" | 4 | 1,2 | 46 | 11,94 | 660 |
| | 36 x 33/4 | 12 | 14" x 13"/1,5" | 4 | 1,44 | 46 | 12,9 | 730 |
| | 45 x 33/4 | 12 | 17,7" x 13"/1,5" | 4 | 1,8 | 46 | 16,20 | 895 |
| | 60 x 33/4 | 12 | 23,6" x 13"/1,5" | 2 | 1,2 | 24 | 11,50 | 291 |
| PEDAÑO BLOCK | 120 x 33/1,4 | - | 48" x 13"/05" | 2 | 2,40 | 40 | 22 | 880 |

PIEZAS ESPECIALES REVESTIMIENTO SPECIAL PIECES WALL TILE / PIÈCES SPÉCIALES POUR REVÊTEMENT

| | FORMATO | ESPESOR | PULGADAS | PZ CAJA | ML | CAJA PLT | PESO CAJA | PESO PLT |
|-----------------------------|---------------|-----------|-------------------|---------|------|----------|------------|------------|
| | SIZES | THICKNESS | SIZES IN INCHES | PC BOX | ML | BOX PLT | WEIGHT BOX | WEIGHT PLT |
| PELDAÑO RCT. | 45 x 33/3 | 11 | 17,7" x 12,5"/1" | 4 | 1,8 | 46 | 16,30 | 895 |
| | 60 x 33/3 | 11 | 23,6" x 13"/1" | 2 | 1,2 | 28 | 9,6 | 285 |
| | 120 x 33/3 | 11 | 48" x 13"/1" | 2 | 2,4 | 14 | 19,2 | 282 |
| | 150 x 33/3 | 11 | 60" x 13"/1" | 2 | 3 | 16 | 25,1 | 416 |
| PELDAÑO RCT. CON GOTERÓN | 61,3 x 32/3 | 11 | 24" x 12,5"/1" | 2 | 0,40 | 28 | 20 | 560 |
| | 33,3 x 33,3/3 | 11 | 13,1" x 12,6"/1" | 4 | 0,44 | 46 | 10,90 | 588,60 |
| REMATE ANG. | 20 x 90/2,6 | 26 | 8" x 35,4" | 2 | 0,36 | 48 | 16,5 | 810 |
| | 20 x 45/2,6 | 26 | 8" x 17,7"/1" | 4 | 0,36 | 80 | 16 | 1.295 |
| REMATE PELD. ANG. IZD/DRCH. | 3 x 32 | 8 | 1" x 12,5" | 20 | 6,4 | 60 | 3,5 | 219 |
| REMATE PELD. RCT. IZD/DRC | 3 x 33 | 9 | 1" x 13" | 20 | 6,4 | 60 | 3,5 | 219 |
| REMATE TRIÁNGULO | 20 x 6,5/2,6 | 26 | 8" x 2,5"/1" | 22 | 4,4 | 120 | 7,6 | 925 |
| VIERTAGUAS | 15 x 22,5/4 | 12 | 5,9" x 8,8"/1,5" | 14 | 3,15 | 64 | 15,08 | 980 |
| | 15 x 30/4 | 12 | 5,9" x 11,8"/1,5" | 14 | 4,2 | 45 | 20,5 | 940 |
| | 15 x 33,3/4 | 12 | 5,9" x 13,1"/1,5" | 10 | 0,50 | 36 | 13,20 | 475,20 |
| ZÓCALO ANG. | 6 x 30/4 | 20 | 2,5" x 11,8"/1,5" | 16 | 4,8 | 96 | 10,3 | 1.004 |
| ZÓCALO | 8,5 x 60 | 9 | 3,5" x 23,6" | 16 | 9,6 | 72 | 16,26 | 1.186 |
| | 8,5 x 90 | 9 | 3,5" x 35,4" | 9 | 8,10 | 66 | 8,65 | 585 |
| | 9 x 30 | 10 | 3,5" x 11,8" | 30 | 9 | 56 | 19,6 | 1.112 |
| | 9 x 36 | 10 | 3,5" x 14" | 30 | 10,8 | 48 | 22,6 | 1.100 |
| | 9 x 45 | 10 | 3,5" x 17,7" | 15 | 6,75 | 80 | 15,5 | 1.260 |
| | 9,8 x 60 | 9 | 3,9" x 23,6" | 16 | 9,6 | 72 | 22 | 1.595 |
| | 9,8 x 66,5 | 9 | 3,9" x 26,5" | 8 | 2,12 | 63 | 10 | 646 |
| | 9,8 x 75 | 9 | 4" x 30" | 11 | 8,25 | 77 | 19,25 | 1.497 |
| | 9,8 x 120 | 9 | 3,9" x 48" | 8 | 9,6 | 63 | 22 | 1.400 |
| | 9 x 30,3 | 9 | 3,5" x 11,9" | 20 | 0,55 | 96 | 12,80 | 1.228,50 |
| | 8 x 33,3 | 9 | 3" x 13,1" | 22 | 0,66 | 84 | 13,20 | 1.108 |
| ZANQUÍN CV. | 9 x 30 | 10 | 3,5" x 11,8" | 30 | 9 | 56 | 16,241 | 924 |
| | 9 x 36 | 10 | 3,5" x 14" | 30 | 10,8 | 48 | 20,2 | 990 |
| | 9 x 45 | 10 | 3,5" x 17,7" | 15 | 6,75 | 80 | 12,40 | 1.007 |
| | 8 x 33,3 | 10 | 3" x 13,1" | 22 | 0,66 | 84 | 13,20 | 1.133,80 |
| ZANQUÍN ANG. | 8,5 x 30 | 9 | 3,5" x 11,8" | 30 | 9 | 48 | 16,24 | 794 |
| | 9 x 30 | 10 | 3,5" x 11,8" | 30 | 9 | 56 | 16,24 | 924 |
| | 9,8 x 30 | 9 | 3,9" x 11,8" | 30 | 9 | 48 | 16,24 | 800 |
| | 9 x 45 | 10 | 3,5" x 17,7" | 15 | 6,78 | 80 | 12,21 | 992 |
| | 9,8 x 66,5 | 9 | 3,9" x 26,5" | 8 | 2,12 | 63 | 10 | 646 |
| ZANQUÍN RCT. | 8,5 x 30 | 9 | 3,5" x 11,8" | 30 | 9 | 48 | 16,24 | 794 |
| | 9 x 30 | 10 | 3,5" x 11,8" | 30 | 9 | 56 | 16,24 | 924 |
| | 9,8 x 30 | 9 | 4" x 11,8" | 30 | 9 | 48 | 16,24 | 795 |
| | 9 x 45 | 10 | 3,5" x 17,7" | 15 | 6,75 | 80 | 12,40 | 1.007 |
| | 9 x 30,3 | 10 | 3,5" x 11,9" | 20 | 0,55 | 96 | 11 | 1.228,80 |
| | 8 x 33,3 | 10 | 3" x 13,1" | 22 | 0,66 | 84 | 13,20 | 1.133,80 |

| | FORMATO | ESPESOR | PULGADAS | PZ CAJA | ML | CAJA PLT | PESO CAJA | PESO PLT |
|--------------------|-------------|-----------|---------------------|---------|------|----------|------------|------------|
| | SIZES | THICKNESS | SIZES IN INCHES | PC BOX | ML | BOX PLT | WEIGHT BOX | WEIGHT PLT |
| C. INT. CUBRECANTO | 4 x 4 | 11 | 1,5" x 1,5" | 100 | 3 | 196 | 1,6 | 310 |
| C. EXT. CUBRECANTO | 4 x 4 | 11 | 1,5" x 1,5" | 100 | 3 | 196 | 0,85 | 182 |
| C. INT. MEDIA CAÑA | 4 x 4 | 11 | 1,5" x 1,5" | 100 | 3 | 196 | 0,85 | 182 |
| C. EXT. MEDIA CAÑA | 4 x 4 | 11 | 1,5" x 1,5" | 100 | 3 | 196 | 1,6 | 310 |
| CUBRECANTO | 4 x 30 x 4 | 11 | 1,5" x 11,8" x 1,5" | 36 | 7,2 | 196 | 1,98 | 405 |
| DEMI-BULLNOSE | 1,5 x 30 | 8 | 0,6" x 11,8" | 50 | 15 | 120 | 2,2 | 276 |
| MEDIA CAÑA INT. | 4 x 30 x 4 | 11 | 1,5" x 11,8" x 1,5" | 36 | 7,2 | 196 | 1,98 | 405 |
| PENCIL | 2,5 x 30 | 8 | 1" x 11,8" | 30 | 9 | 196 | 2 | 410 |
| VIERTAGUAS | 15 x 22,5/4 | 12 | 5,9" x 8,8" | 14 | 3,15 | 64 | 15,08 | 980 |

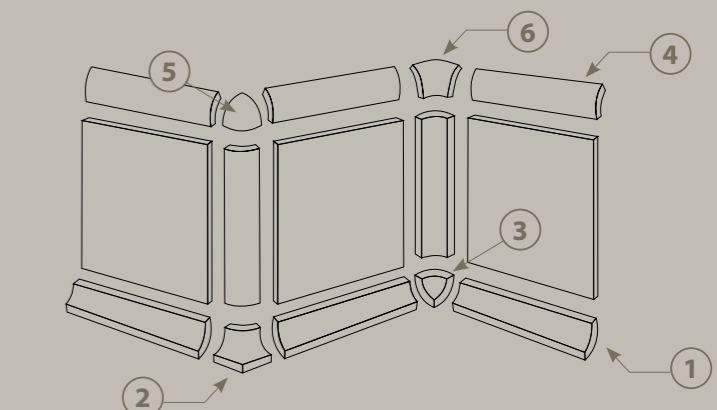
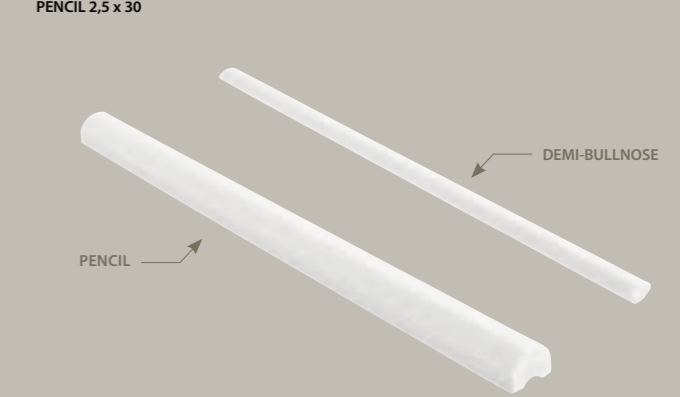
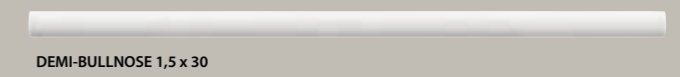



ESTAMOS CONECTADOS

WE ARE CONNECTING
RESTONS CONNECTÉS

En Natucer, creemos en la importancia de mantenernos conectados con nuestros clientes y colaboradores. Por eso nos aseguramos de ofrecer contenido actualizado a diario a través de nuestras plataformas digitales, como la web y las redes sociales, brindándote información sobre nuestras colecciones más recientes, tendencias en diseño cerámico y todo aquello que define nuestro compromiso con la innovación y la calidad.

Síguenos y descubre un mundo de inspiración cerámica diseñado especialmente para ti.

In Natucer, we believe in the importance of staying connected with our customers and partners. That's why we make sure to offer updated content daily through our digital platforms, such as our website and social media, providing you with information about our latest collections, trends in ceramic design, and everything that defines our commitment to innovation and quality.

Follow us and discover a world of ceramic inspiration specially designed for you.

Chez Natucer, nous croyons en l'importance de rester connectés avec nos clients et collaborateurs. C'est pourquoi nous proposons un contenu actualisé quotidiennement via notre site web et nos réseaux sociaux : collections, tendances en design céramique et innovations qui définissent notre engagement envers la qualité.

Suivez-nous et découvrez un univers d'inspiration céramique conçu spécialement pour vous.

